

Ultra Low ON-Resistance, Low Voltage, Dual, SPDT Analog Switch

FEATURES

- **-3dB Bandwidth: 30MHz**
- **High Speed, Typically 50ns**
- **Supply Range: +1.8V to +5.5V**
- **Low ON-State Resistance, 0.6Ω(TYP)**
- **Break-Before-Make Switching**
- **Rail-to-Rail Operation**
- **TTL/CMOS Compatible**
- **Extended Industrial Temperature Range: -40°C to +125°C**

DESCRIPTION

The RS2323 is a dual, low on-resistance, single-pole double-throw (SPDT) analog switch that is designed to operate from 1.8 V to 5.5 V.

The RS2323 device can handle both analog and digital signals. It features fast switching speeds (50ns) and low on-resistance (0.6Ω TYP).

Applications include signal gating, chopping, modulation or demodulation (modem), and signal multiplexing for analog-to-digital and digital-to-analog conversion systems.

APPLICATIONS

- **Wearable Devices**
- **Battery-Operated Equipment**
- **Signal Gating, Chopping, Modulation or Demodulation (Modem)**
- **Portable Computing**
- **Cell Phones**

FUNCTION TABLE

LOGIC	NO	NC
0	OFF	ON
1	ON	OFF

PIN CONFIGURATIONS

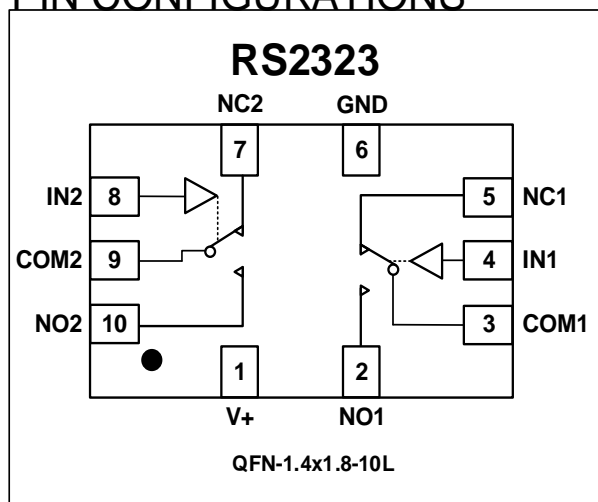

PIN DESCRIPTION

NAME	PIN	FUNCTION
V+	1	Power Supply
NO1, NO2	2, 10	Normally-Open Terminal
COM1, COM2	3, 9	Common Terminal
IN1, IN2	4, 8	Digital Control Pin
NC1, NC2	5, 7	Normally-Closed Terminal
GND	6	Ground

SPECIFICATIONS

Absolute Maximum Ratings

Over operating free-air temperature range (unless otherwise noted) ⁽¹⁾

SYMBOL	PARAMETER	MIN	MAX	UNIT
V ₊	Supply Voltage	-0.3	6.0	V
V _{IN}	Input Voltage (All inputs)	-0.3	(V ₊)+0.3	
I _{IN}	Continuous Current NO, NC, or COM	-500	+500	mA
I _{PEAK}	Peak Current NO, NC, or COM	-800	+800	
T _J	Junction Temperature		150	°C
T _{stg}	Storage temperature	-65	+150	

(1) Stresses above these ratings may cause permanent damage. Exposure to absolute maximum conditions for extended periods may degrade device reliability. These are stress ratings only, and functional operation of the device at these or any other conditions beyond those specified is not implied.

ESD Ratings

		VALUE	UNIT
V _(ESD)	Electrostatic discharge	Human-body model (HBM)	±1000
		Machine Model (MM)	±100

Recommended Operating Conditions

Over operating free-air temperature range (unless otherwise noted) ⁽³⁾

SYMBOL	PARAMETER	MIN	MAX	UNIT
V _{CC}	Supply Voltage	1.8	5.5	V
T _A	Operating temperature	-40	+125	°C

Thermal Information

THERMAL METRIC		RS2323	UNIT
		10 PINS	
		QFN-1.4x1.8-10L	
R _{θJA}	Junction-to-ambient thermal resistance	120	°C/W

PACKAGE/ORDERING INFORMATION

PRODUCT	ORDERING NUMBER	TEMPERATURE RANGE	PACKAGE LEAD	PACKAGE MARKING (1/2)	PACKAGE OPTION
RS2323	RS2323XUTQK10	-40°C ~125°C	QFN-1.4x1.8-10L	2323X	Tape and Reel,4000

NOTE:

- (1) There may be additional marking, which relates to the lot trace code information(data code and vendor code), the logo or the environmental category on the device.
- (2) X = Date Code

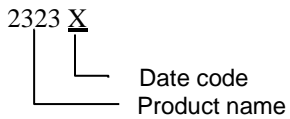
MARKING INFORMATION

ELECTRICAL CHARACTERISTICS

$V_+ = 5.0\text{ V}$, $T_A = -40^\circ\text{C}$ to 125°C (unless otherwise noted)

PARAMETER	SYMBOL	CONDITIONS	V+	T _A	MIN	TYP	MAX	UNITS
ANALOG SWITCH								
Analog Signal Range	V_{NO}, V_{NC}, V_{COM}			FULL	0		V_+	V
On-Resistance	R_{ON}	$0 \leq (V_{NO} \text{ or } V_{NC}) \leq V_+$, $I_{COM} = -10\text{mA}$, Switch ON, See Figure 1	5V	+25°C		0.6	1.0	Ω
				FULL			1.2	Ω
			3.3V	+25°C		1.0	1.5	Ω
				FULL			1.7	Ω
On-Resistance Match Between Channels	ΔR_{ON}	$0 \leq (V_{NO} \text{ or } V_{NC}) \leq V_+$, $I_{COM} = -10\text{mA}$, Switch ON, See Figure 1	5V	+25°C		0.04	0.1	Ω
				FULL			0.12	Ω
			3.3V	+25°C		0.04	0.1	Ω
				FULL			0.12	Ω
On-Resistance Flatness	$R_{FLAT(ON)}$	$0 \leq (V_{NO} \text{ or } V_{NC}) \leq V_+$, $I_{COM} = -10\text{mA}$, Switch ON, See Figure 1	5V	+25°C		0.18	0.3	Ω
				FULL			0.4	Ω
			3.3V	+25°C		0.54	0.7	Ω
				FULL			0.8	Ω
NC,NO OFF Leakage Current	$I_{NC(OFF)}, I_{NO(OFF)}$	$V_{NO} \text{ or } V_{NC} = 0.3\text{V}$, $V_+/2$ $V_{COM} = V_+/2$, 0.3V See Figure 2	1.8 to 5.5V	FULL			1	μA
NC,NO,COM ON Leakage Current	$I_{NC(ON)}, I_{NO(ON)}, I_{COM(ON)}$	$V_{NO} \text{ or } V_{NC} = 0.3\text{V}$, Open $V_{COM} =$ Open, 0.3V See Figure 2	1.8 to 5.5V	FULL			1	μA
DIGITAL CONTROL INPUTS⁽¹⁾								
Input High Voltage	V_{INH}		5V	FULL	1.5			V
			3.3V	FULL	1.3			V
Input Low Voltage	V_{INL}		5V	FULL			0.6	V
			3.3V	FULL			0.5	V
Input Leakage Current	I_{IN}	$V_{IN} = V_{IO} \text{ or } 0$	1.8 to 5.5V	FULL			1	μA

(1) All unused digital inputs of the device must be held at V_{IO} or GND to ensure proper device operation.

ELECTRICAL CHARACTERISTICS (continued)
 $V_+ = 5.0\text{ V}$, TEMP= -40°C to 125°C (unless otherwise noted)

PARAMETER	SYMBOL	CONDITIONS	V+	TEMP	MIN	TYP	MAX	UNITS
DYNAMIC CHARACTERISTICS								
Turn-On Time	t_{ON}	$V_{COM} = V_+$, $R_L = 300\Omega$, $C_L = 35\text{pF}$, See Figure 5	5V	+25°C		50		ns
			3.3V			50		
Turn-Off Time	t_{OFF}	$V_{COM} = V_+$, $R_L = 300\Omega$, $C_L = 35\text{pF}$, See Figure 5	5V	+25°C		15		ns
			3.3V			17		
Break-Before-Make Time Delay	t_{BBM}	$V_{NO1} = V_{NC1} = V_{NO2} = V_{NC2} = 3\text{V}$, $R_L = 300\Omega$, $C_L = 35\text{pF}$, See Figure 6	5V	+25°C		10		ns
			3.3V			11		
Off Isolation	O_{ISO}	$R_L = 50\Omega$, Switch OFF, See Figure 8	f = 100KHz	+25°C		-68		dB
			f = 10KHz	+25°C		-86		dB
-3dB Bandwidth	BW	Switch ON, $R_L = 50\Omega$ See Figure 7		+25°C		30		MHz
NC,NO OFF Capacitance	$C_{NC(OFF)}$, $C_{NO(OFF)}$	V_{NC} or $V_{NO}=V_+/2$ or GND, Switch OFF See Figure 4		+25°C		80		pF
NC,NO,COM ON Capacitance	$C_{NC(ON)}$, $C_{NO(ON)}$, $C_{COM(ON)}$	V_{NC} or $V_{NO}=V_+/2$ or GND, Switch ON See Figure 4		+25°C		350		pF
POWER REQUIREMENTS								
Power Supply Range	V_+			FULL	1.8		5.5	V
Power Supply Current	I_+	$V_{IN} = \text{GND or } V_+$	5.5V	FULL			1	μA

TYPICAL CHARACTERISTICS

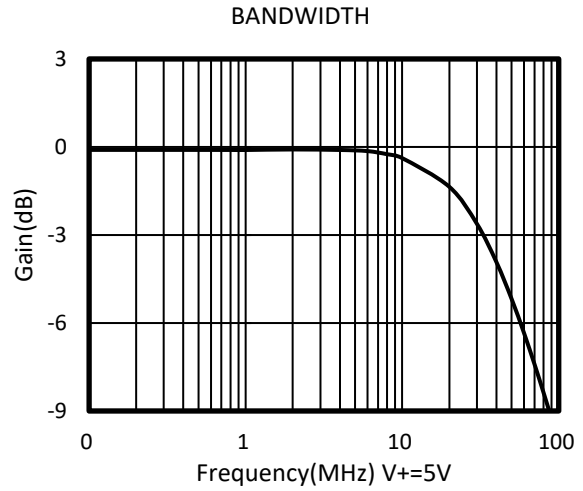
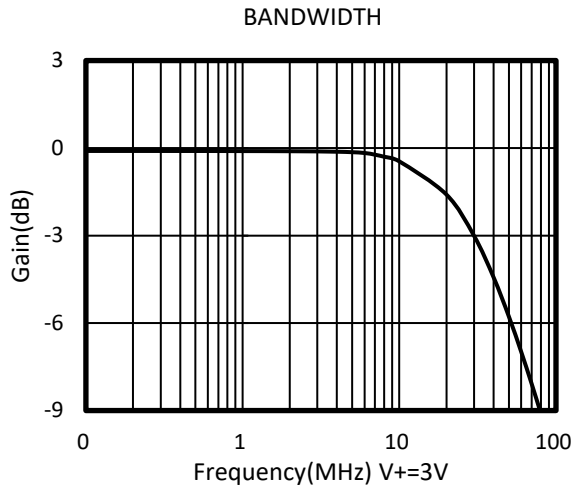

Typical ron as a Function of Input Voltage (VI) for VI = 0 to V+

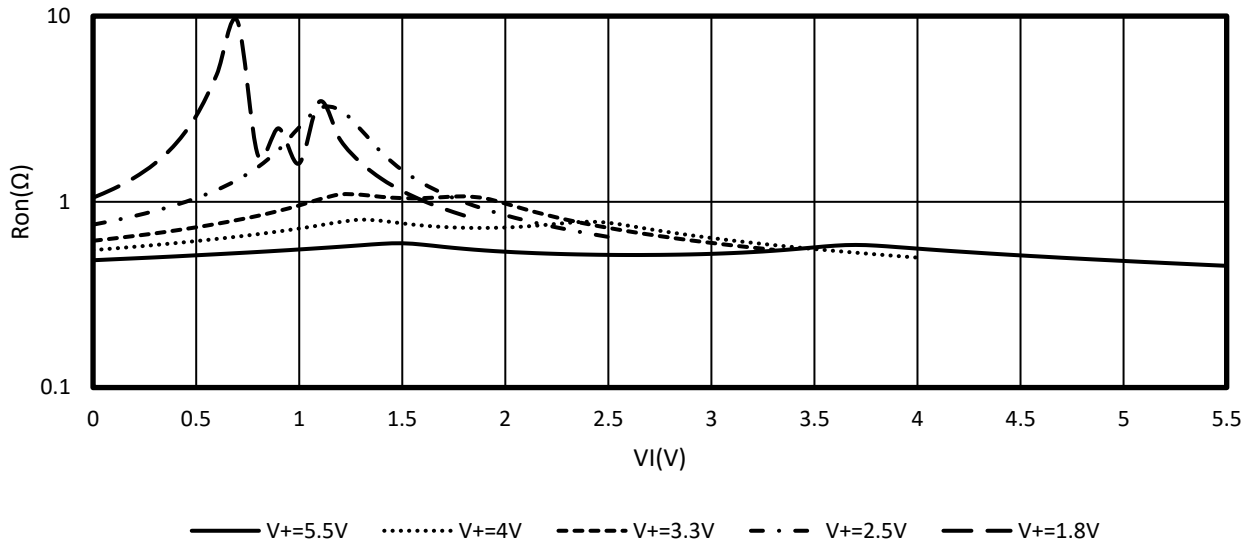

Parameter Measurement Information

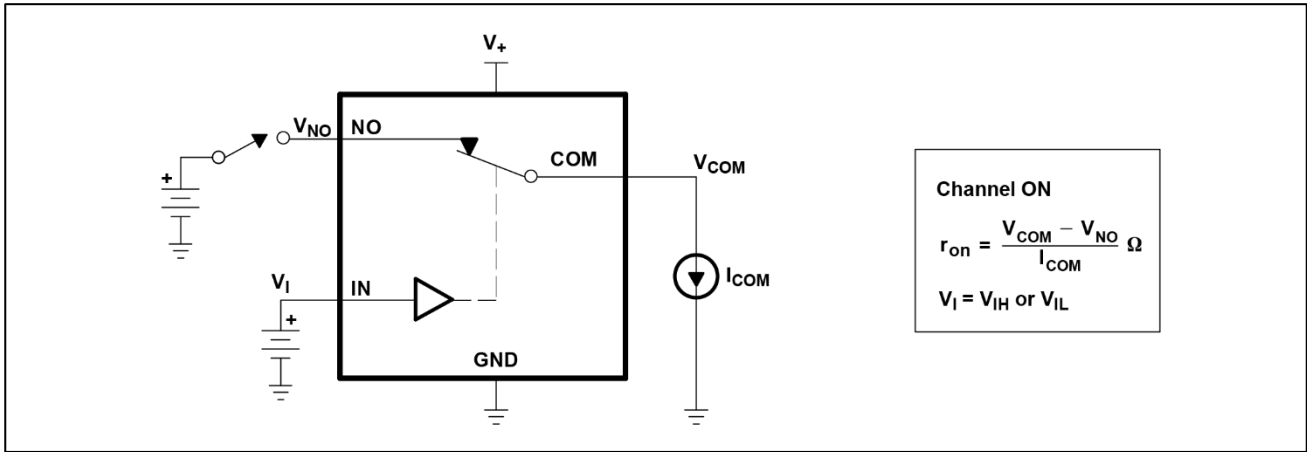

Figure 1. ON-State Resistance (r_{on})

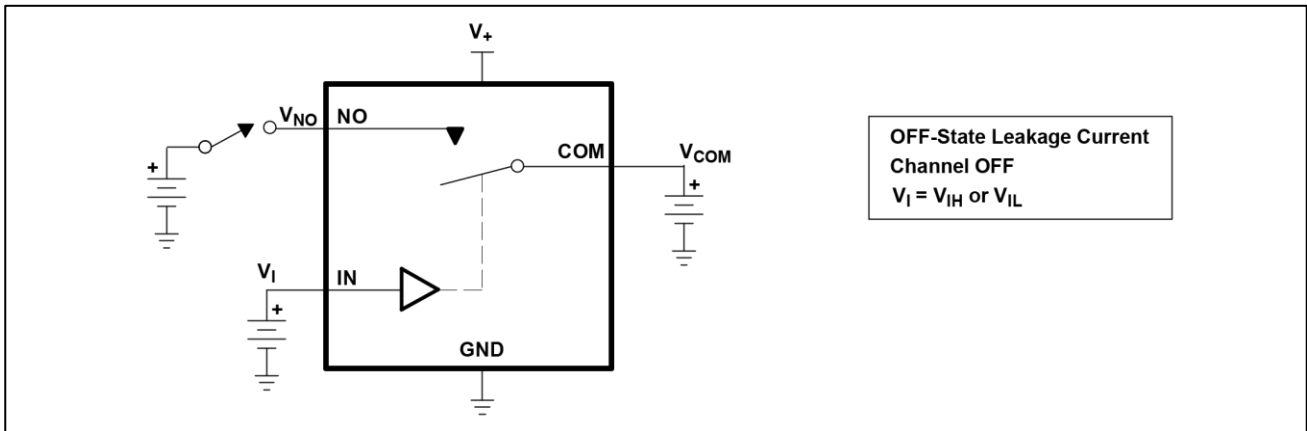

Figure 2. OFF-State Leakage Current ($I_{COM(OFF)}$, $I_{NO(OFF)}$)

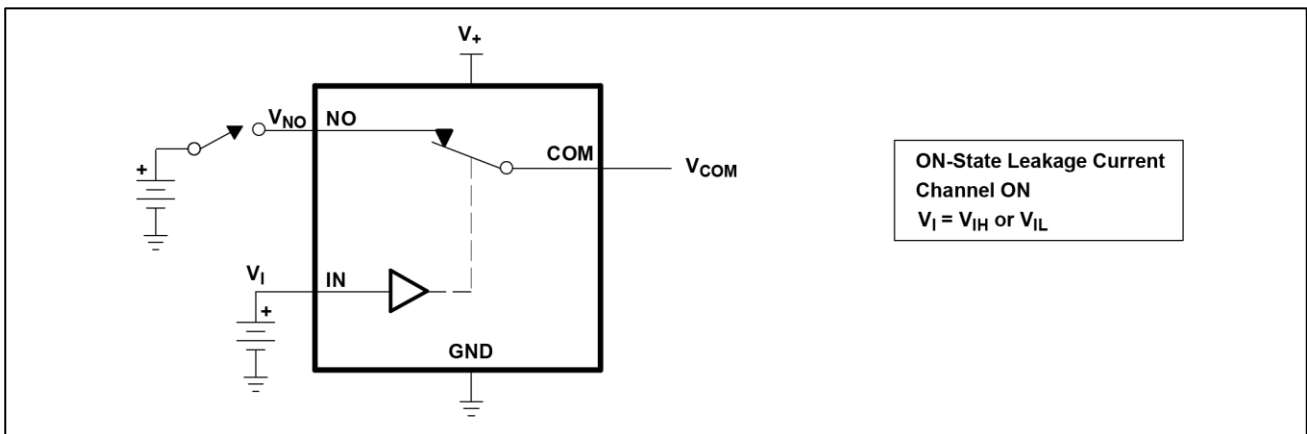
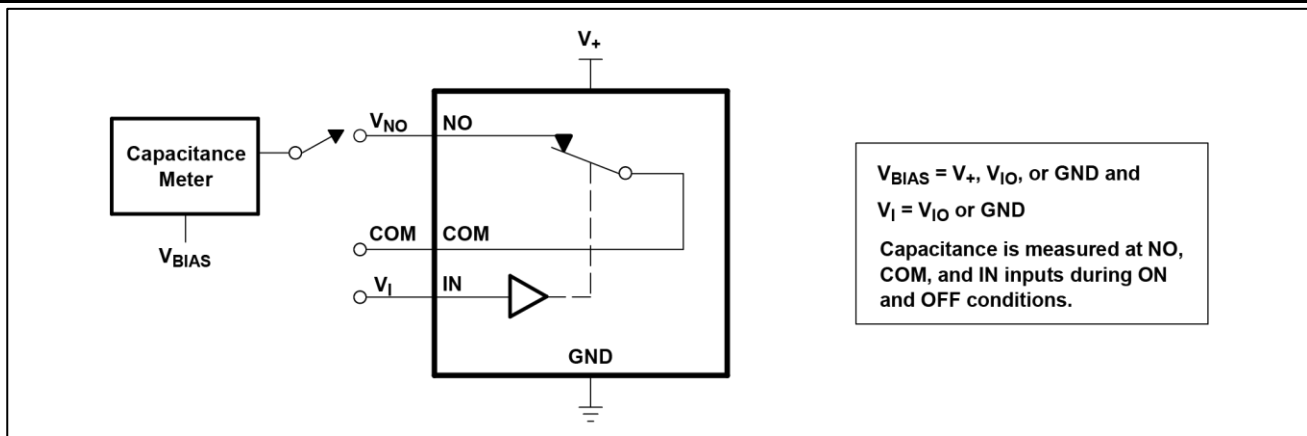
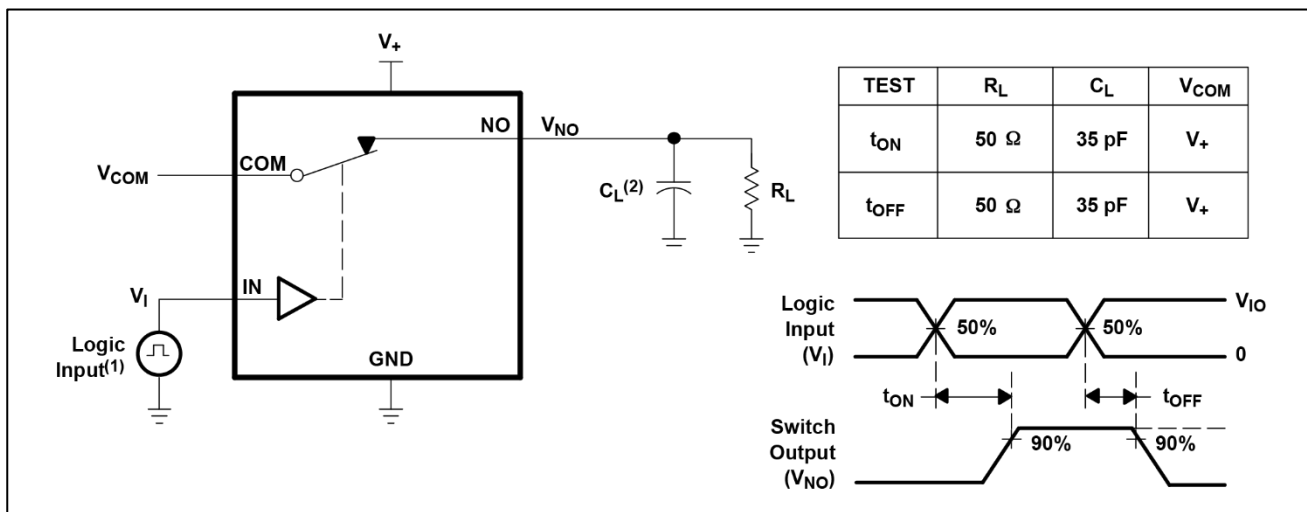
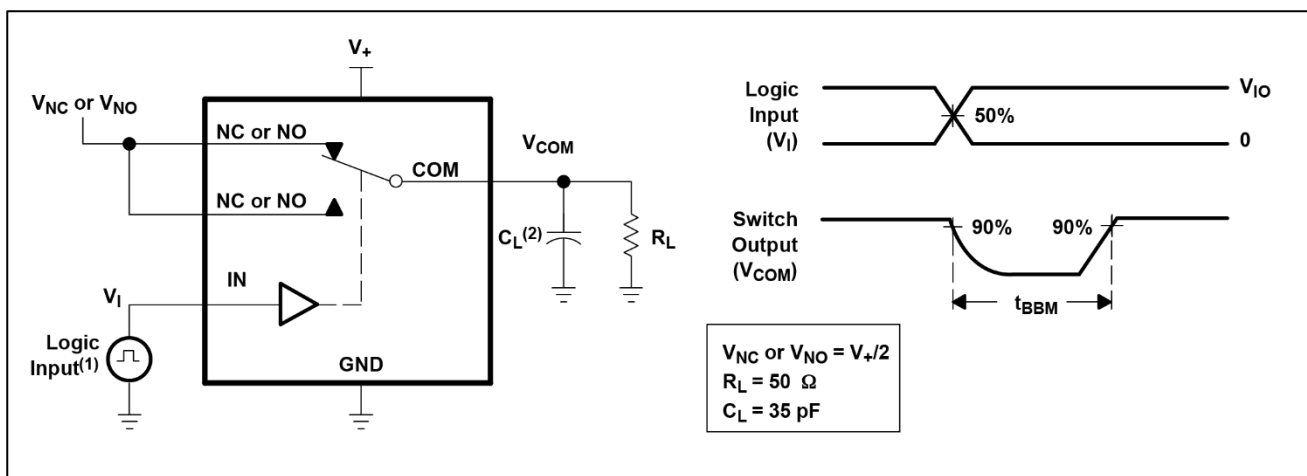

Figure 3. ON-State Leakage Current ($I_{COM(ON)}$, $I_{NO(ON)}$)

Figure 4. Capacitance (C_I , $C_{COM(OFF)}$, $C_{COM(ON)}$, $C_{NO(OFF)}$, $C_{NO(ON)}$)

Figure 5. Turn-On (t_{ON}) and Turn-Off Time (t_{OFF})

Figure 6. Break-Before-Make Time (t_{BBM})

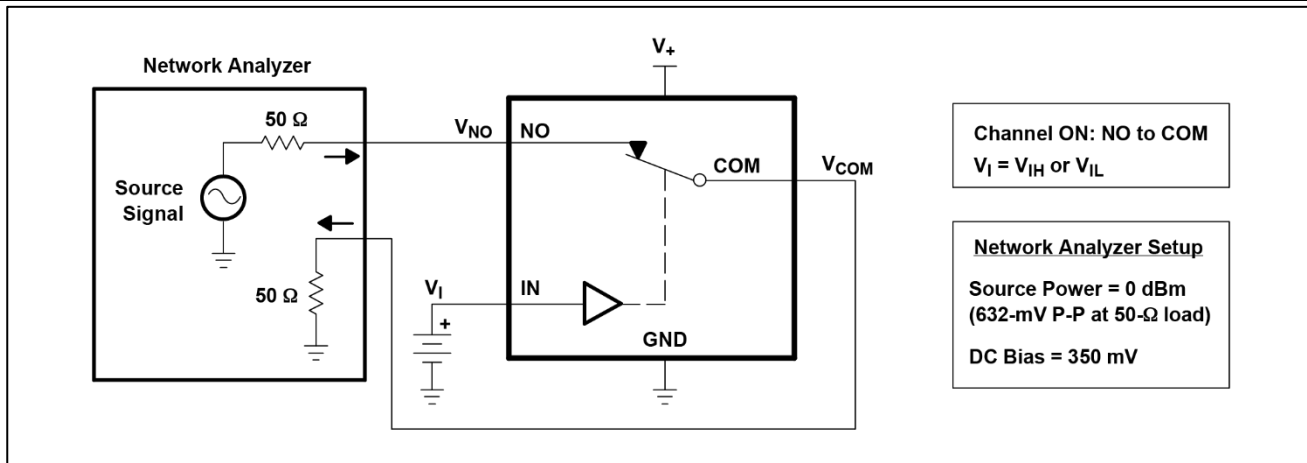

Figure 7. Bandwidth (BW)

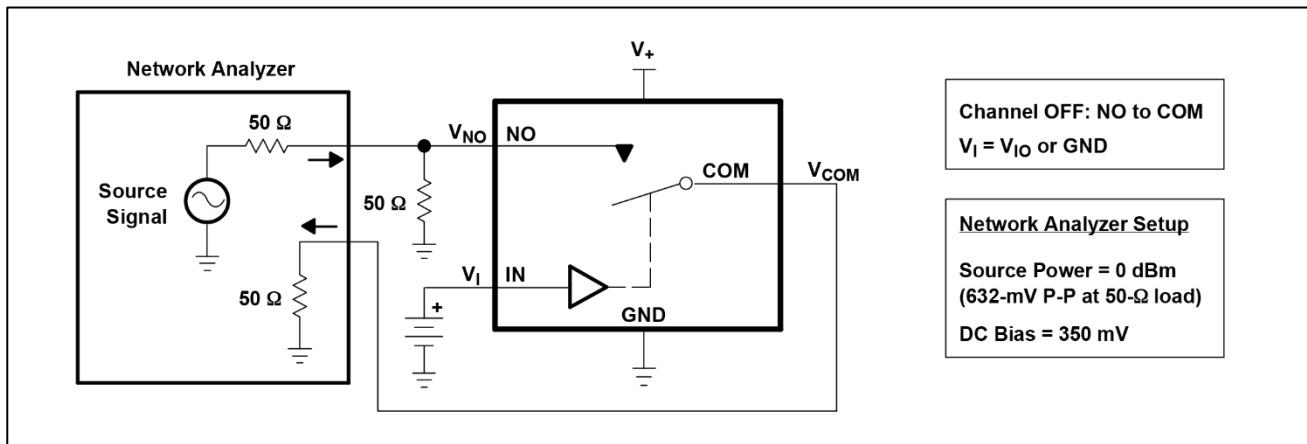

Figure 8. OFF Isolation (O_{ISO})

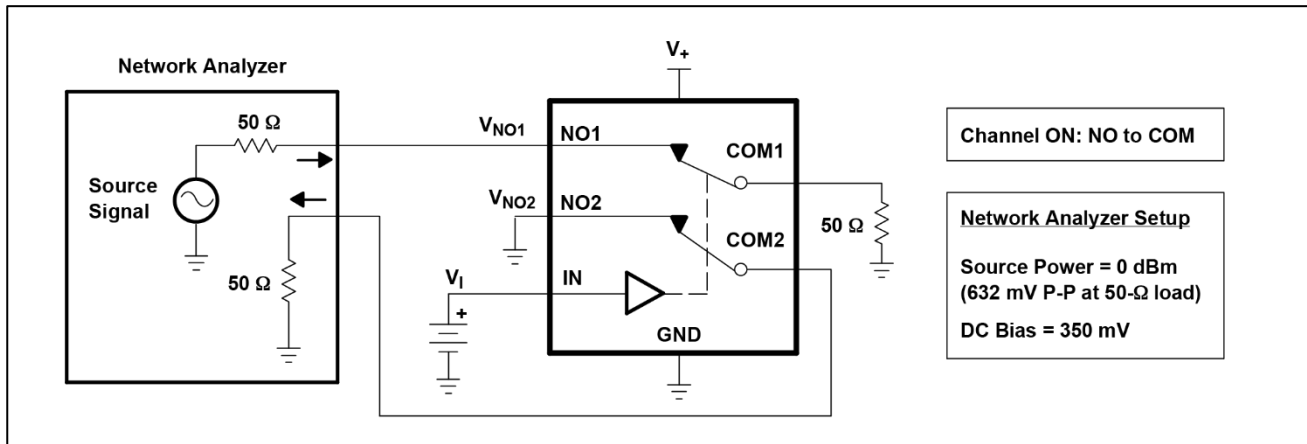

Figure 9. Crosstalk (X_{TALK})

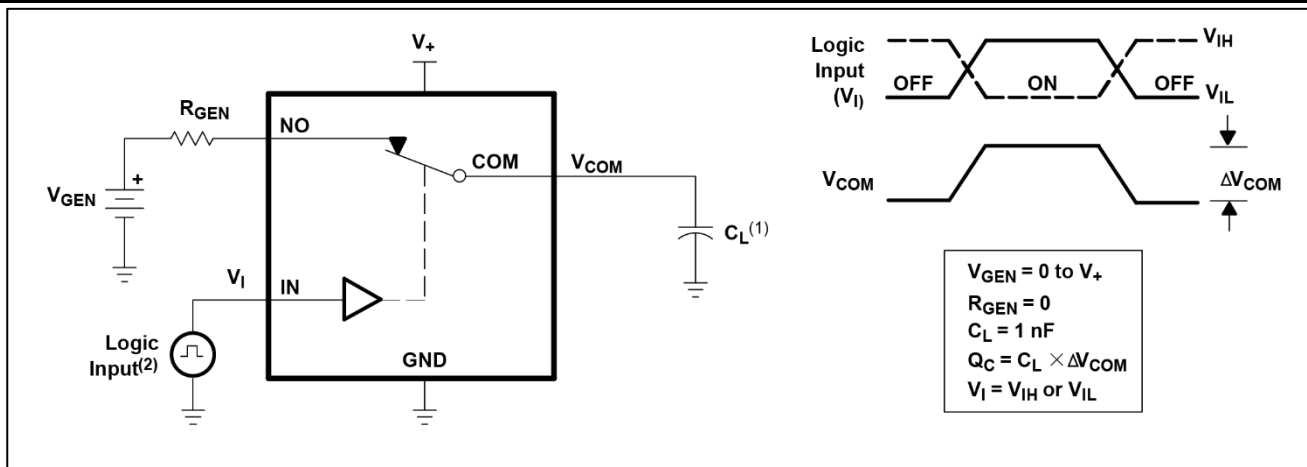

Figure 10. Charge Injection (Q_C)

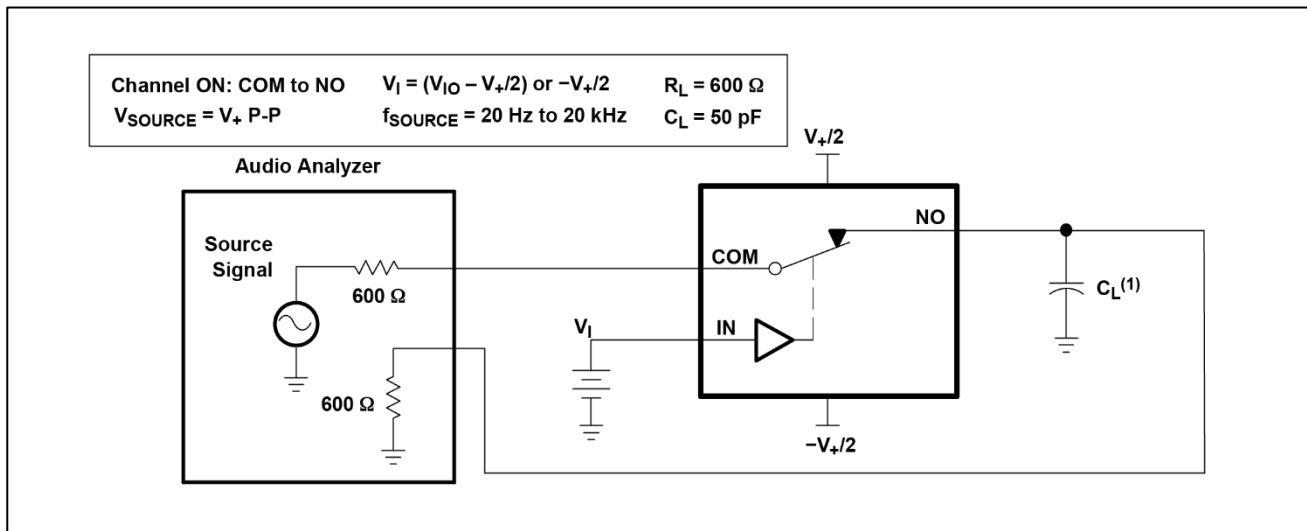

Figure11.Total Harmonic Distortion (THD)

PACKAGE OUTLINE DIMENSIONS

QFN-1.4x1.8-10L

