

让 润 石 芯 跳 动 在 电 子 产 品 世 界 的 每 个 角 落

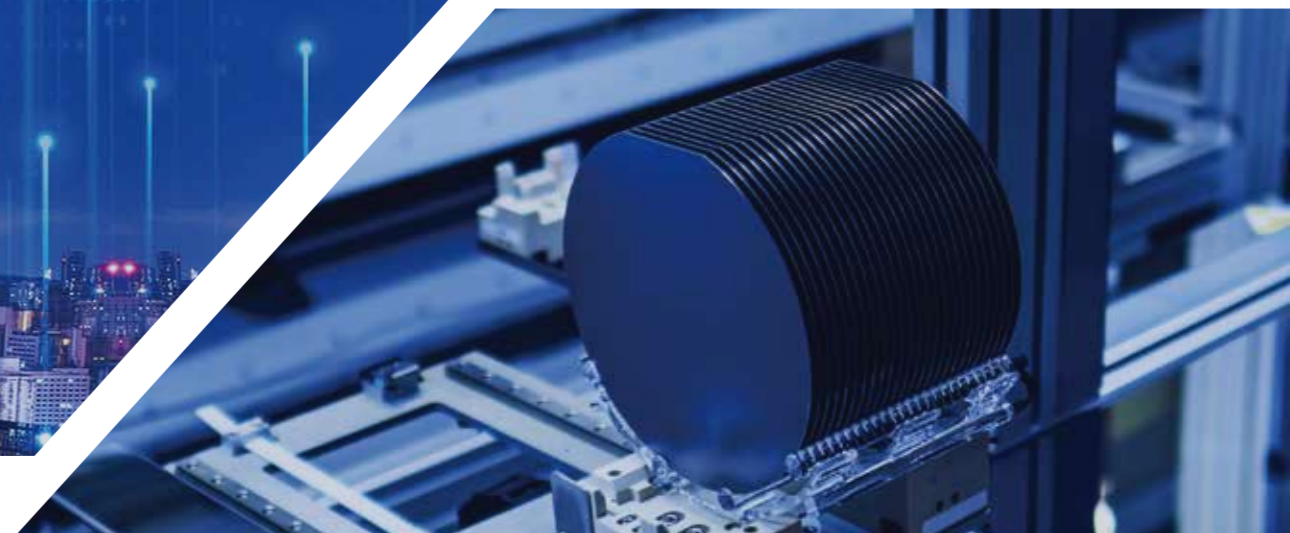

☎ 销售热线: 400-8090-866

✉ 邮箱: sales@run-ic.com



江苏润石科技有限公司
Jiangsu Runic Technology Co.,Ltd

江苏地址

江苏省无锡市新吴区弘毅路8号金乾座20层 / 电话: +86-510-85387528

深圳地址

广东省深圳市南山区高新中二道2号深圳软件园1期4栋201室 / 电话: +86-755-23595309

韩国地址 (South Korea)

13F #102, 428 Seolleung-ro, Gangnam-gu, Seoul, Korea, 06192
E-mail : overseas@run-ic.com / Tel: +82 (10) 2669-2588



访问官方网站



关注官方微信

产品选型手册

Product Selection Guide

江苏润石科技有限公司 |
Jiangsu Runic Technology Co.,Ltd

October
2022

自主创新 / 品质至上 / 团结协作 / 成就客户

公司愿景

成为全球一流的模拟芯片公司

公·司·介·绍 |
Company profile

公司使命

让润石芯跳动在电子产品世界的每个角落

江苏润石科技有限公司是一家专注于高性能、高品质模拟/混合信号集成电路研发和销售的高科技半导体设计公司。

公司主要产品包括信号链和电源管理两大类，其中信号链包含运算放大器、比较器、模拟开关、数据转换器、电平转换、电压基准源、逻辑器件；电源管理包含线性稳压器、DC/DC、负载开关、复位及马达驱动。产品广泛用于汽车电子、新能源、工业控制、消费类电子、医疗设备、安防监控、仪器仪表、智能家居以及信创等应用领域。

公司总部位于江苏省无锡市，扎根本土，服务全球。公司依托无锡市良好的集成电路产业环境，整合上下游优势资源，致力于汽车电子、新能源、工业控制、消费类电子、物联传感和医疗电子等领域的模拟芯片产品的研发设计，目前已完成多个门类的芯片设计和开发；同时积极布局新能源汽车领域，全力推进国产车规级模拟芯片的研发和生产，并于2022年7月通过车用IC可靠度 AEC-Q100 认证！

公司在深圳设立全球销售和技术服务中心，在国内的北京、上海、天津、郑州、杭州、成都、武汉、合肥、青岛、中国台湾以及海外的韩国首尔等地均有驻地人员就近提供全方位的服务。通过几年的耕耘，逐渐形成了较为成熟的国内外市场销售体系和健全完善的售前、售中、售后技术服务体系，拥有众多国内外行业标杆企业客户。同时也建立了快速的响应机制，及时了解客户需求、市场前景和行业趋势。

江苏润石始终坚持“自主创新，品质至上，团结协作，成就客户”为公司的核心价值，不断地推出具备更强竞争力和良好市场前景的模拟/混合信号芯片产品，携手客户共同发展，共创辉煌，让润石芯跳动在电子产品世界的每个角落，矢志成为全球一流的模拟芯片公司！



Directory 产品目录

荣誉 Honor

- 高新技术企业
Hi-Tech Company
- 江苏省民营科技企业
Jiangsu Private Hi-Tech Enterprise
- 北京大学电子与信息领域工程博士研究生工作站
Beijing University Electronic and Information Engineering PhD Workstation
- 2018第一届我用中国芯最佳创新奖
2018 China IC Best Innovation Award
- 2019年度最佳国产电源IC产品奖
2019 Best Power IC Product Award
- 2019硬核中国芯最具潜力IC设计企业奖
2019 China Core Most Potential IC Design Company Award
- 2020年度最佳国产模拟电路芯片产品奖
2020 Best Analog IC Award
- 2020中国模拟半导体优秀企业奖
2020 China Analog Semiconductor Excellent Enterprise Award
- 2021中国IC设计成就奖
2021 China IC Design Achievement Award
- 2021中国模拟半导体飞跃成就奖优秀企业奖
2021 China Analog Semiconductor Leap Achievement Outstanding Business Award
- 2021硬核中国芯最具潜力IC设计企业奖
2021 "China Chip" Most Potential IC Design Company Award
- 2021年度最佳信号链芯片产品奖
2021 Best Signal Chain Product Award

■ 精密运算放大器 1 Precision Operational Amplifier	■ 特殊开关系列 7 Special Switch Series
■ 高速运算放大器 2 High-Speed Operational Amplifier	■ 高压线性稳压器 8 High Voltage Linear Regulator
■ 通用运算放大器 2 General Operational Amplifier	■ 高精度线性稳压器 8 High Precision Linear Regulator
■ 低噪声运算放大器 3 Low Noise Operational Amplifier	■ 模数转换器-精密ADC 9 Analog-Digital Converter-Precise ADC
■ 低失调电压运算放大器 3-4 Low Offset Operational Amplifier	■ 电平转换器 10 Level Converter
■ 纳安功耗运算放大器 4 Nano Power Operational Amplifier	■ 小逻辑 10-11 Small Logic Series
■ 高压高精度放大器 4-5 High Voltage Precision Operational Amplifier	■ 并联电压基准源 12 Shunt voltage reference
■ 高压通用放大器 5 High Voltage General Operational Amplifier	■ 负载开关 12 Load Switch
■ 仪表放大器 5 Instrumentation Amplifier	■ DC/DC 13 DC/DC
■ 微功耗比较器 6 Nano Power Comparator	■ 电压检测和复位 13 Supervisory Circuit
■ 高速比较器 6 High Speed Comparator	■ 马达驱动 13 Motor Driver
■ 高压比较器 6 High Voltage Comparator	
■ 模拟开关 7 Analog Switch	

运算放大器和比较器【Operational Amplifier And Comparator】

江苏润石为客户提供类型广泛的运算放大器和比较器，能够更好的满足客户不同种类的应用需求。主要包括精密运算放大器、高速运算放大器、低噪声运算放大器、低失调电压运算放大器、低功耗运算放大器、高压高精度运算放大器、专用运算放大器、低功耗比较器和高速比较器等系列产品，具有高品质、高性能、选型丰富等特点，广泛应用于医疗电子，汽车电子，工业控制，智能家居和消费类电子等领域。

RUNIC Technology Co.,Ltd provides customers with a wide range of operational amplifiers and comparators, which can better meet customers' different application requirements. These products mainly include High Precision Operational Amplifier, High Speed Operational Amplifier, Low Noise Operational Amplifier, Low Offset Voltage Operational Amplifier, Nano Power Operational Amplifier, High Voltage High Precision Operational Amplifier, Customized Operational Amplifier, Micro Power Comparator, and serial product etc. All these products have the characteristics of high quality, high performance, selection of rich, and are widely used in medical electronics, automotive electronics, industrial control, smart home and consumer electronics and other fields.

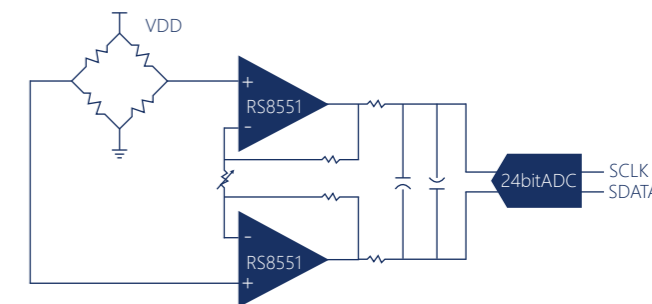

精密运算放大器 | Precision Operational Amplifier

Part Number	Amplifiers per Package	V _{OS} (Offset Voltage) Max@25°C (uV)	TC of V _{OS} Typ (uV/°C)	I _B Typ (pA)	E _{NOISE} 0.01Hz~10Hz (uVpp)	Rail-to-Rail I/O	Total Supply Voltage (Min)	Total Supply Voltage (Max)	GBW Typ (MHz)	Slew Rate Typ (V/us)	I _q /Amp Typ (uA)	Additional Feature	E _{NOISE} Typ@1kHz (nV/√Hz)	A _{OL} Typ (dB)	CMRR Typ (dB)	Operating Temperature Range (°C)	Package
RS8511	1	40	0.05	50	1.6	In,Out	2.3	5.5	0.35	0.17	60	EMI Hardened	70	130	130	-40 to 125	SOIC-8,MSOP-8,SOT23-5
RS8512	2	40	0.05	50	1.6	In,Out	2.3	5.5	0.35	0.17	60	EMI Hardened	70	130	130	-40 to 125	SOIC-8,MSOP-8,TDFN2X2-8L
RS8514	4	40	0.05	50	1.6	In,Out	2.3	5.5	0.35	0.17	60	EMI Hardened	70	130	130	-40 to 125	SOIC-14,TSSOP-14
RS8521	1	5	0.005	10	3.2	In,Out	2.3	5.5	0.35	0.17	60	EMI Hardened	140	130	130	-40 to 125	SOIC-8,MSOP-8,SOT23-5
RS8522	2	5	0.005	10	3.2	In,Out	2.3	5.5	0.35	0.17	60	EMI Hardened	140	130	130	-40 to 125	SOIC-8,MSOP-8,TDFN2X2-8L
RS8524	4	5	0.005	10	3.2	In,Out	2.3	5.5	0.35	0.17	60	EMI Hardened	140	130	130	-40 to 125	SOIC-14,TSSOP-14
RS8538	1	5	0.005	50	1.3	In,Out	2.5	5.5	1.6	0.7	180	EMI Hardened	60	130	130	-40 to 125	SOIC-8,MSOP-8,SOT23-5
RS8539	2	5	0.005	50	1.3	In,Out	2.5	5.5	1.6	0.7	180	EMI Hardened	60	130	130	-40 to 125	SOIC-8,MSOP-8
RS8551	1	5	0.005	50	0.75	In,Out	2.7	5.5	4.5	2.7	640	EMI Hardened	35	130	130	-40 to 125	SOIC-8,MSOP-8,SOT23-5
RS8552	2	5	0.005	50	0.75	In,Out	2.7	5.5	4.5	2.7	640	EMI Hardened	35	130	130	-40 to 125	SOIC-8,MSOP-8,TDFN2X2-8L
RS8554	4	5	0.005	50	0.75	In,Out	2.7	5.5	4.5	2.7	640	EMI Hardened	35	130	130	-40 to 125	SOIC-14,TSSOP-14
RS8557	1	20	0.03	50	0.93	In,Out	2.7	5.5	4.3	2.5	650	EMI Hardened	45	130	130	-40 to 125	SOIC-8,MSOP-8,SOT23-5
RS8558	2	20	0.03	50	0.93	In,Out	2.7	5.5	4.3	2.5	650	EMI Hardened	45	130	130	-40 to 125	SOIC-8,MSOP-8
RS8559	4	20	0.03	50	0.93	In,Out	2.7	5.5	4.3	2.5	650	EMI Hardened	45	130	130	-40 to 125	SOIC-14,TSSOP-14
RS8501*	1	20	0.05	5	25	In,Out	2.2	5.5	0.015	0.01	5	EMI Hardened	—	130	130	-40 to 125	SOIC-8,MSOP-8,SOT23-5
RS8502*	2	20	0.05	5	25	In,Out	2.2	5.5	0.015	0.01	5	EMI Hardened	—	130	130	-40 to 125	SOIC-8,MSOP-8
RS8504*	4	20	0.05	5	25	In,Out	2.2	5.5	0.015	0.01	5	EMI Hardened	—	130	130	-40 to 125	SOIC-14,TSSOP-14
RS8561	1	20	0.1	100	0.48	In,Out	2.9	5.5	11	8.5	1300	EMI Hardened	32	130	130	-40 to 125	SOIC-8,MSOP-8,SOT23-5
RS8562	2	20	0.1	100	0.48	In,Out	2.9	5.5	11	8.5	1300	EMI Hardened	32	130	130	-40 to 125	SOIC-8,MSOP-8
RS8564	4	20	0.1	100	0.48	In,Out	2.9	5.5	11	8.5	1300	EMI Hardened	32	130	130	-40 to 125	SOIC-14,TSSOP-14

* 产品研发中

高速运算放大器 | High-Speed Operational Amplifier

Part Number	Amplifiers per Package	GBW Typ (MHz)	Shutdown	Total Supply Voltage (Min)	Total Supply Voltage (Max)	V _{os} Max@25°C (mV)	I _q /Amp Typ (mA)	I _B Typ (pA)	Slew Rate Typ (V/us)	E _{NOISE} Typ@1kHz (nV/√Hz)	Operating Temperature Range (°C)	Package
RS8751	1	250	N	2.5	5.5	7.5	2.9	1	180	8	-40 to 125	SOT23-5,SOIC-8
RS8752	2	250	N	2.5	5.5	7.5	2.9	1	180	8	-40 to 125	SOIC-8,MSOP-8, TSSOP8
RS8754	4	250	N	2.5	5.5	7.5	2.9	1	180	8	-40 to 125	SOIC-14,TSSOP-14
RS8761*	1	500	N	2.5	5.5	8	8.2	6	420	5.6	-40 to 125	SOT23-5,SOIC-8
RS8762*	2	500	N	2.5	5.5	8	8.2	6	420	5.6	-40 to 125	SOIC-8,MSOP-8
RS8764*	4	500	N	2.5	5.5	8	8.2	6	420	5.6	-40 to 125	SOIC-14,TSSOP-14
RS8701*	1	50	N	2.5	5.5	0.25	7	1	50	4.5	-40 to 125	SOT23-5
RS8702	2	50	N	2.5	5.5	0.25	7	1	80	4.5	-40 to 125	SOIC-8,MSOP-8
RS8704*	4	50	N	2.5	5.5	0.25	7	1	80	4.5	-40 to 125	SOIC-14,TSSOP-14

通用运算放大器 | General Operational Amplifier

Part Number	Amplifiers per Package	V _{os} Max@25°C (mV)	I _q /Amp Typ (uA)	Total Supply Voltage (Min)	Total Supply Voltage (Max)	GBW Typ (MHz)	Slew Rate Typ (V/ms)	Rail-to-Rail I/O	TC of V _{os} Typ (uV/°C)	E _{NOISE} Typ@1kHz (nV/√Hz)	I _B Typ (pA)	A _{OL} Typ (dB)	CMRR Typ (dB)	Additional Feature	Operating Temperature Range (°C)	Package
RS121	1	5	7	2.5	5.5	0.15	50	In,Out	3.1	77	1	110	95	—	-40 to 125	SOT23-5,SOIC-8,MSOP-8
RS122	2	5	7	2.5	5.5	0.15	50	In,Out	3.1	77	1	110	95	—	-40 to 125	SOIC-8,MSOP-8,TDFN2X2-8L
RS124	4	5	7	2.5	5.5	0.15	50	In,Out	3.1	77	1	110	95	—	-40 to 125	SOIC-14,TSSOP-14
RS221	1	3.5	18	2.5	5.5	0.5	180	In,Out	2.9	30	1	110	90	—	-40 to 125	SOT23-5,SOIC-8,MSOP-8
RS222	2	3.5	18	2.5	5.5	0.5	180	In,Out	2.9	30	1	110	90	—	-40 to 125	SOIC-8,MSOP-8,TDFN2X2-8L
RS224	4	3.5	18	2.5	5.5	0.5	180	In,Out	2.9	30	1	110	90	—	-40 to 125	SOIC-14,TSSOP-14
RS321	1	4.5	60	2.2	5.5	1.1	500	In,Out	2.9	23	1	100	80	—	-40 to 125	SOT23-5,SOIC-8,MSOP-8
RS358	2	4.5	60	2.2	5.5	1.1	500	In,Out	2.9	23	1	100	80	—	-40 to 125	SOIC-8,MSOP-8,TDFN2X2-8L
RS324	4	4.5	60	2.2	5.5	1.1	500	In,Out	2.9	23	1	100	80	—	-40 to 125	SOIC-14,TSSOP-14
RS6331	1	3	58	2.2	5.5	1.1	500	In,Out	2	22	1	110	90	—	-40 to 125	SOT23-5,SOIC-8,MSOP-8
RS6331S	1	3	58	2.2	5.5	1.1	500	In,Out	2	22	1	110	90	Shutdown	-40 to 125	SOT23-6
RS6332	2	3	58	2.2	5.5	1.1	500	In,Out	2	22	1	110	90	—	-40 to 125	SOIC-8,MSOP-8,TSSOP-8 TDFN2x2-8L
RS6332S	2	3	58	2.2	5.5	1.1	500	In,Out	2	22	1	110	90	Shutdown	-40 to 125	MSOP-10
RS6334	4	3	58	2.2	5.5	1.1	500	In,Out	2	22	1	110	90	—	-40 to 125	SOIC-14,TSSOP-14,TQFN3X3-16L

* 产品研发中

低噪声运算放大器 | Low Noise Operational Amplifier

Part Number	Amplifiers per Package	E_{NOISE} Typ@1kHz (nV/√Hz)	GBW Typ (MHz)	Slew Rate Typ (V/us)	I_q /Amp Typ (uA)	Total Supply Voltage (Min)	Total Supply Voltage (Max)	Rail-to-Rail I/O	V_{OS} Max@25°C (mV)	TC of V_{OS} Typ (uV/°C)	I_B Typ (pA)	A_{OL} Typ (dB)	CMRR Typ (dB)	Additional Feature	Operating Temperature Range (°C)	Package
RS521	1	15	3.6	1.8	260	2.5	5.5	In,Out	3	2	1	110	87	—	-40 to 125	SOT23-5
RS522	2	15	3.6	1.8	260	2.5	5.5	In,Out	3	2	1	110	87	—	-40 to 125	SOIC-8,MSOP-8,TDFN2X2-8L
RS524	4	15	3.6	1.8	260	2.5	5.5	In,Out	3	2	1	110	87	—	-40 to 125	SOIC-14,TSSOP-14
RS621	1	11	7	3.7	600	2.5	5.5	In,Out	3	2	1	106	92	—	-40 to 125	SOT23-5,SC70-5
RS622	2	11	7	3.7	600	2.5	5.5	In,Out	3	2	1	106	92	—	-40 to 125	SOIC-8,MSOP-8,TSSOP8 TDFN2X2-8L, TDFN3X3-8L
RS624	4	11	7	3.7	600	2.5	5.5	In,Out	3	2	1	106	92	—	-40 to 125	SOIC-14,TSSOP-14,TDFN3X2-14L
RS721	1	9.5	10	7	1150	2.5	5.5	In,Out	2.5	2.6	1	96	85	—	-40 to 125	SOT23-5,TDFN2X2-6L,SC70-5
RS722	2	9.5	10	7	1150	2.5	5.5	In,Out	2.5	2.6	1	96	85	—	-40 to 125	SOIC-8,MSOP-8,TDFN2X2-8L, TDFN3X3-8L
RS724	4	9.5	10	7	1150	2.5	5.5	In,Out	2.5	2.6	1	96	85	—	-40 to 125	SOIC-14,TSSOP-14
RS821	1	8.5	14	10	1900	2.5	5.5	In,Out	2.5	1.6	1	100	88	—	-40 to 125	SOT23-5
RS821S	1	8.5	14	10	1900	2.5	5.5	In,Out	2.5	1.6	1	100	88	Shutdown	-40 to 125	SOT23-6
RS822	2	8.5	14	10	1900	2.5	5.5	In,Out	2.5	1.6	1	100	88	—	-40 to 125	SOIC-8,MSOP-8
RS822S	2	8.5	14	10	1900	2.5	5.5	In,Out	2.5	1.6	1	100	88	Shutdown	-40 to 125	MSOP-10
RS824	4	8.5	14	10	1900	2.5	5.5	In,Out	2.5	1.6	1	100	88	—	-40 to 125	SOIC-14,TSSOP-14

低失调电压运算放大器 | Low Offset Operational Amplifier

Part Number	Amplifiers per Package	V_{OS} Max@25°C (mV)	GBW Typ (MHz)	Slew Rate Typ (V/us)	I_q /Amp Typ (uA)	Total Supply Voltage (Min)	Total Supply Voltage (Max)	Rail-to-Rail I/O	E_{NOISE} Typ@1kHz (nV/√Hz)	TC of V_{OS} Typ (uV/°C)	I_B Typ (pA)	A_{OL} Typ (dB)	CMRR Typ (dB)	Operating Temperature Range (°C)	Package
RS6331P	1	0.5	1.1	0.5	85	2.5	5.5	In,Out	22	2	10	120	95	-40 to 125	SOT23-5
RS6332P	2	0.5	1.1	0.5	85	2.5	5.5	In,Out	22	2	10	120	95	-40 to 125	SOIC-8,MSOP-8
RS6334P	4	0.8	1.1	0.5	85	2.5	5.5	In,Out	22	2	10	120	95	-40 to 125	SOIC-14,TSSOP-14
RS621P	1	0.5	7	4	720	2.5	5.5	In,Out	11	2	10	110	96	-40 to 125	SOT23-5
RS622P	2	0.5	7	4	720	2.5	5.5	In,Out	11	2	10	110	96	-40 to 125	SOIC-8,MSOP-8
RS624P	4	0.5	7	4	720	2.5	5.5	In,Out	11	2	10	110	96	-40 to 125	SOIC-14,TSSOP-14
RS721P	1	0.5	10	6	1100	2.5	5.5	In,Out	9.5	2.6	10	110	97	-40 to 125	SOT23-5

低失调电压运算放大器 | Low Offset Operational Amplifier

Part Number	Amplifiers per Package	V _{os} Max@25°C (mV)	GBW Typ (MHz)	Slew Rate Typ (V/us)	I _q /Amp Typ (uA)	Total Supply Voltage (Min)	Total Supply Voltage (Max)	Rail-to-Rail I/O	E _{NOISE} Typ@1kHz (nV/√Hz)	TC of V _{os} Typ (uV/°C)	I _B Typ (pA)	A _{OL} Typ (dB)	CMRR Typ (dB)	Operating Temperature Range (°C)	Package
RS722P	2	0.5	10	6	1100	2.5	5.5	In,Out	9.5	2.6	10	110	97	-40 to 125	SOIC-8,MSOP-8
RS724P	4	0.5	10	6	1100	2.5	5.5	In,Out	9.5	2.6	10	110	97	-40 to 125	SOIC-14,TSSOP-14
RS821P	1	0.5	14	10	1900	2.5	5.5	In,Out	7	1.6	10	100	88	-40 to 125	SOT23-5
RS822P	2	0.5	14	10	1900	2.5	5.5	In,Out	7	1.6	10	100	88	-40 to 125	SOIC-8,MSOP-8
RS824P	4	0.8	14	10	1900	2.5	5.5	In,Out	7	1.6	10	100	88	-40 to 125	SOIC-14,TSSOP-14

纳安功耗运算放大器 | Nano Power Operational Amplifier

Part Number	Amplifiers per Package	I _q /Amp Typ (uA)	Total Supply Voltage (Min)	Total Supply Voltage (Max)	GBP Typ (KHz)	Slew Rate Typ (V/ms)	E _{NOISE} Typ@1kHz (nV/√Hz)	V _{os} Max@25°C (mV)	TC of V _{os} Typ (uV/°C)	I _B Typ (pA)	A _{OL} Typ (dB)	CMRR Typ (dB)	Rail-to-Rail I/O	Operating Temperature Range (°C)	Package
RS8021	1	0.35	1.4	5.5	5	1.5	360	3	2.3	1	106	90	Yes	-40 to 125	SOT23-5,SC70-5
RS8022*	2	0.35	1.4	5.5	5	1.5	360	3	2.3	1	106	90	Yes	-40 to 125	SOIC-8,MSOP-8,TDFN2X2-8L
RS8024*	4	0.35	1.4	5.5	5	1.5	360	3	2.3	1	106	90	Yes	-40 to 125	SOIC-14,TSSOP-14
RS8031	1	0.75	1.4	5.5	15	7.5	160	3	2.3	1	106	90	Yes	-40 to 125	SOT23-5,SC70-5
RS8032	2	0.75	1.4	5.5	15	7.5	160	3	2.3	1	106	90	Yes	-40 to 125	SOIC-8,MSOP-8
RS8034	4	0.75	1.4	5.5	15	7.5	160	3	2.3	1	106	90	Yes	-40 to 125	SOIC-14,TSSOP-14
RS8051	1	0.67	1.4	5.5	100	30	160	5	2.3	1	85	75	Yes	-40 to 125	SOT23-5,SC70-5,SOIC-8,MSOP-8
RS8052	2	0.67	1.4	5.5	100	30	160	5	2.3	1	85	75	Yes	-40 to 125	SOIC-8,MSOP-8,TDFN2X2-8L
RS8054	4	0.67	1.4	5.5	100	30	160	5	2.3	1	85	75	Yes	-40 to 125	SOIC-14,TSSOP-14

高压高精度放大器 | High Voltage Precision Operational Amplifier

Part Number	Amplifiers per Package	V _{os} (Offset Voltage) Max@25°C (uV)	TC of V _{os} Typ (uV/°C)	I _B Typ (pA)	Total Supply Voltage (Min)	Total Supply Voltage (Max)	GBW Typ (MHz)	Slew Rate Typ (V/us)	Rail-to-Rail I/O	I _q /Amp Typ (uA)	Additional Feature	E _{NOISE} 0.01Hz~10Hz (uVpp)	E _{NOISE} Typ@1kHz (nV/√Hz)	A _{OL} Typ (dB)	CMRR Typ (dB)	Operating Temperature Range (°C)	Package
RS8631	1	30	0.15	100	3.3	36	0.37	0.12	Out	125	EMI Hardened	0.75	45	120	120	-40 to 125	SOIC-8,MSOP-8
RS8632	2	30	0.15	100	3.3	36	0.37	0.12	Out	125	EMI Hardened	0.75	45	120	120	-40 to 125	SOIC-8,MSOP-8
RS8634	4	30	0.15	100	3.3	36	0.37	0.12	Out	125	EMI Hardened	0.75	45	120	120	-40 to 125	SOIC-14,TSSOP-14
RS8651	1	20	0.15	100	3.3	32	2	1	Out	900	EMI Hardened	0.6	30	130	120	-40 to 85	SOIC-8,MSOP-8
RS8652	2	20	0.15	100	3.3	32	2	1	Out	900	EMI Hardened	0.6	30	130	120	-40 to 125	SOIC-8,MSOP-8

* 产品研发中

■ 高压高精度放大器 | High Voltage Precision Operational Amplifier

Part Number	Amplifiers per Package	V _{os} (Offset Voltage) Max@25°C (uV)	TC of V _{os} Typ (uV/°C)	I _B Typ (pA)	Total Supply Voltage (Min)	Total Supply Voltage (Max)	GBW Typ (MHz)	Slew Rate Typ (V/us)	Rail-to-Rail I/O	I _q /Amp Typ (uA)	Additional Feature	E _{NOISE} 0.01Hz~10Hz (uVpp)	E _{NOISE} Typ@1kHz (nV/√Hz)	A _{OL} Typ (dB)	CMRR Typ (dB)	Operating Temperature Range (°C)	Package
RS8654	4	20	0.15	100	3.3	36	2	1	Out	900	EMI Hardened	0.45	40	120	120	-40 to 125	SOIC-14,TSSOP-14
RS8661	1	10	0.15	50	4.5	36	5	1.8	Out	1300	EMI Hardened	0.18	10	130	130	-40 to 125	SOIC-8,MSOP-8
RS8662	2	10	0.15	50	4.5	36	5	1.8	Out	1300	EMI Hardened	0.18	10	130	130	-40 to 125	SOIC-8,MSOP-8
RS8664	4	10	0.15	50	4.5	36	5	1.8	Out	1300	EMI Hardened	0.18	10	130	130	-40 to 125	SOIC-14,TSSOP-14
RS07	1	50	3.0	1000	5.0	36	1.9	1.0	Out	1300	Cl. Hardened	4.0	20	150	120	-40 to 125	SOIC-8

■ 高压通用放大器 | High Voltage General Operational Amplifier

Part Number	Amplifiers per Package	Total Supply Voltage (Min)	Total Supply Voltage (Max)	GBW Typ (MHz)	Slew Rate Typ (V/us)	Rail-to-Rail I/O	V _{os} Max@25°C (mV)	I _q /Amp Typ (mA)	E _{NOISE} Typ@1kHz (nV/√Hz)	I _B Typ (pA)	A _{OL} Typ (dB)	Sink/Source Current Typ (mA)	Operating Temperature Range (°C)	Package
RS8401*	1	3.0	36	0.23	0.11	Out	3.0	0.02	45	10	110	50	-40 to 125	SOT-23-5
RS8402*	2	3.0	36	0.23	0.11	Out	3.0	0.02	45	10	110	50	-40 to 125	SOIC-8,MSOP-8
RS8404*	4	3.0	36	0.23	0.11	Out	3.0	0.02	45	10	110	50	-40 to 125	SOIC-14,TSSOP-14
RS8411	1	3.0	36	1.2	0.67	Out	4.0	0.15	45	10	115	70	-40 to 125	SOT-23-5
RS8412	2	3.0	36	1.2	0.67	Out	4.0	0.15	45	10	115	70	-40 to 125	SOIC-8,MSOP-8
RS8414	4	3.0	36	1.2	0.67	Out	4.0	0.15	45	10	115	70	-40 to 125	SOIC-14,TSSOP-14
RS8421	1	4.4	36	5.0	3.0	Out	3.0	1.8	44	10	100	90	-40 to 125	SOT-23-5
RS8422	2	4.4	36	5.0	3.0	Out	3.0	1.8	44	10	100	90	-40 to 125	SOIC-8,MSOP-8
RS8424	4	4.4	36	5.0	3.0	Out	3.0	1.8	44	10	100	90	-40 to 125	SOIC-14,TSSOP-14
RS8451	1	5.0	36	8.0	5.0	Out	3.0	2.75	35	10	100	150	-40 to 125	SOT-23-5
RS8452	2	5.0	36	8.0	5.0	Out	3.0	2.75	35	10	100	150	-40 to 125	SOIC-8,MSOP-8
RS8454	4	5.0	36	8.0	5.0	Out	3.0	2.75	35	10	100	150	-40 to 125	SOIC-14,TSSOP-14
RS8462	2	3.0	36	10.0	23.0	In/Out	1.0	2.2	25	20	120	75	-40 to 125	SOIC-8,MSOP-8
RS8464	4	3.0	36	10.0	23.0	In/Out	1.0	2.2	25	20	120	75	-40 to 125	SOIC-14,TSSOP-14

■ 仪表放大器 | Instrumentation Amplifier

Part Number	Common Mode Voltage (Max) (V)	Common Mode Voltage (Min) (V)	Input Offset (+/-)(Max) (uV)	Input Offset Drift (+/-)(Typ) (uV/C)	Gain (V/V)	Gain Error (%)	CMRR (Min) (dB)	Bandwidth (kHz)	Supply Voltage (Max) (V)	Supply Voltage (Min) (V)	I _q (Max) (mA)	Operating Temperature Range (°C)	Package
RS199*	26	-0.1	150	0.1	50,100,200	1	100	80,30,14	36	2.7	0.115	-40 to 125	SC70-6
RS620*	36	3	150	2	1,10,100,1000	0.15	120	800,120,12,1	36	2.7	0.2	-40 to 125	SOIC-8

* 产品研发中

微功耗比较器 | Nano Power Comparator

Part Number	Number of Channels (#)	Iq per channel (Typ) (nA)	Feature	Vs (Min) (V)	Vs (Max) (V)	Vos (Offset Voltage @ 25°C) (Max) (mV)	Propagation Delay (L to H) (μs)	Propagation Delay (H to L) (μs)	t _{rise} (ns)	t _{fall} (ns)	Output Type	Operating Temperature Range (°C)	Package
RS8901	1	400	N	1.4	5.5	3	40	9	240	260	Push-Pull	-40 to 125	SOT23-5,SC70-5
RS8905	2	400	N	1.4	5.5	3	40	9	240	260	Push-Pull	-40 to 125	SOIC-8,MSOP-8
RS8907	1	400	N	1.4	5.5	3	40	9	240	260	Push-Pull	-40 to 125	SOT23-5,SC70-5
RS8912	1	4850	1.2V Ref Out	2.3	5.5	3.5	68	67	12000	12000	Push-Pull	-40 to 85	SOT23-6, DFN1.6*1.6-6L

高速比较器 | High Speed Comparator

Part Number	Comparators per Package	Iq/Comp Typ (μA)	t _r , H to L @Vcc=5V PD (ns)	t _r , L to H @Vcc=5V PD (ns)	Rise Time @Vcc=5V (ns)	Fall Time @Vcc=5V (ns)	Vos Max@25°C (mV)	Vcc (V)	Input Common Mode Voltage Range(V)	Logic Output	Rail-to-Rail Output	Operating Temperature Range (°C)	Package
RS8904	1	120	25	30	2	2	20	2.7~5.5	-0.1~Vs+0.1	Push-Pull	Yes	-40 to 125	SOT23-5,SC70-5
RS8906*	1	1300	6	6	8	6	5	2.7~5.5	-0.1~Vs+0.1	Push-Pull	Yes	-40 to 125	SOT23-5,SC70-5
RS8908*	1	22	95	120	8	6	5	2.7~5.5	-0.1~Vs+0.1	Push-Pull	Yes	-40 to 125	SOT23-5,SC70-5
RS8910*	2	22	95	120	8	6	5	2.7~5.5	-0.1~Vs+0.1	Push-Pull	Yes	-40 to 125	SOIC-8,MSOP-8
RS8911*	1	150	30	22	11	8	5	2.7~5.5	-0.1~Vs-1.2	Push-Pull	Yes	-40 to 125	SOT23-5
RS331	1	50	185	210		34	3.5	1.8~5.5	-0.1~Vs+0.1	Open-Drain(NFET)	Yes	-40 to 125	SOT23-5
RS393	2	50	185	210		34	3.5	1.8~5.5	-0.1~Vs+0.1	Open-Drain(NFET)	Yes	-40 to 125	SOIC-8,MSOP-8
RS339	4	50	185	210		34	3.5	1.8~5.5	-0.1~Vs+0.1	Open-Drain(NFET)	Yes	-40 to 125	SOIC-14,TSSOP-14

高压比较器 | High Voltage Comparator

Part Number	Comparators per Package	Iq/Comp Typ (uA)	t _r , H toL @Vcc=5V PD(us)	t _r , L toH @Vcc=5V PD(us)	Vos Max@25°C (mV)	Vcc (Min) (V)	Vcc (Max) (V)	Input Common Mode Voltage Range(V)	Logic Output	Operating Temperature Range (°C)	Package
LM331	1	230	0.4	0.9	4	3	32	-0.1~ Vs-1.5	Open-Drain(NFET)	-40 to 125	SOT-23-5
LM393	2	20	2	6.1	3.5	3	32	-0.1~ Vs-1.5	Open-Drain(NFET)	-40 to 125	SOIC-8,MSOP-8
LM2903	2	230	0.4	0.9	4	3.3	32	-0.1~ Vs-1.5	Open-Drain(NFET)	-40 to 125	SOIC-8,MSOP-8
LM2901	4	230	0.4	0.9	4	3.3	32	-0.1~ Vs-1.5	Open-Drain(NFET)	-40 to 125	SOIC-14,TSSOP-14

* 产品研发中

模拟开关 [Analog Switch]

江苏润石为客户提供了一系列的低压模拟开关，包含多种信号范围的单通道和多通道模拟开关产品，具有低导通阻抗（低至0.5Ω）、高速、高性能、小封装、选型丰富等特点，能够更好的满足客户需求。

模拟开关 | Analog Switch

Part Number	CH	Type	R _{ON} (Ω)	-3dB Bandwidth (MHz)	V _{CC} (Min) (V)	V _{CC} (Max) (V)	I _q (μA)	V _{INH} (Min) (V)	V _{INL} (Max) (V)	t _{ON} (ns)	t _{OFF} (ns)	Operating Temperature Range (°C)	Package
RS2101	1	1:2	3.0	120	1.8	5.5	1	1.5	0.6	29	17	-40°C to 125°C	SOT363(SC70-6)
RS2102	2	1:2	3.0	120	1.8	5.5	1	1.5	0.6	29	17	-40°C to 125°C	MSOP-10
RS2103	1	1:2	0.6	30	1.8	5.5	1	1.5	0.6	50	15	-40°C to 125°C	SOT363(SC70-6),SOT23-6,MSOP-8
RS2105	2	1:2	0.6	30	1.8	5.5	1	1.5	0.6	50	15	-40°C to 125°C	MSOP-10,TDFN-3X3-10L
RS2057	1	1:2	4.5	300	1.8	5.5	1	1.5	0.6	30	25	-40°C to 125°C	SOT363(SC70-6),SOT23-6
RS2058	2	1:2	4.5	300	1.8	5.5	1	1.5	0.6	30	25	-40°C to 125°C	MSOP-10,QFN-1.4X1.8-10L
RS2099	4	1:2	0.6	30	1.8	5.5	1	1.5	0.6	50	15	-40°C to 125°C	QFN3X3-16L,TSSOP-16
RS2117	2	1:2	4	400	2.5	5.5	1	1.5	0.5	15	10	-40°C to 85°C	QFN-1.4X1.8-10L,MSOP-10
RS2118	2	1:2	0.6	80	2.5	5.5	1	1.5	0.5	15	10	-40°C to 85°C	QFN-1.4X1.8-10L
RS2257	1	1:2	0.6	30	1.8	5.5	1	1.5	0.6	50	15	-40°C to 125°C	SOT363(SC70-6),SOT23-6
RS2299	4	1:2	4.5	300	1.8	5.5	1	1.5	0.6	30	25	-40°C to 125°C	QFN-3X3-16L
RS2251	1	1:8	48	180	2.5	5.5	1	1.7	0.5	65	80	-40°C to 125°C	SOIC-16(SOP16),SSOP-16,TSSOP-16, QFN-3X3-16L
RS2252	2	1:4	48	180	2.5	5.5	1	1.7	0.5	70	80	-40°C to 125°C	SOIC-16(SOP16),SSOP-16,TSSOP-16, QFN-3X3-16L
RS2253	3	1:2	48	180	2.5	5.5	1	1.7	0.5	90	70	-40°C to 125°C	SOIC-16(SOP16),SSOP-16,TSSOP-16, QFN-3X3-16L
RS2254	4	1:1	24	180	2.5	5.5	1	1.5	0.5	40	100	-40°C to 125°C	TSSOP-14,SOIC-14(SOP14)
RS2255	1	1:4	24	180	2.5	5.5	1	1.5	0.5	40	100	-40°C to 125°C	MSOP-10
RS2323	2	1:2	0.6	30	1.8	5.5	1	1.5	0.6	50	15	-40°C to 125°C	QFN-1.4X1.8-10L
RS2227	2	1:2	6	550	1.8	5.5	1	1.6	0.5	20	15	-40°C to 85°C	MSOP-10,QFN-1.4X1.8-10L
RS2228	2	1:2	6	550	1.8	5.5	1	1.6	0.5	20	15	-40°C to 85°C	QFN-1.4X1.8-10L,MSOP-10
RS2166	1	1:1	4.5	300	1.8	5.5	1	1.5	0.6	30	25	-40°C to 125°C	SOT23-5, SOT353(SC70-5)
RS2266	2	1:1	4.5	300	1.8	5.5	1	1.5	0.6	30	25	-40°C to 125°C	DFN2x3-8, MSOP-8
RS2259	4	1:1	0.6	30	1.8	5.5	1	1.5	0.6	50	15	-40°C to 125°C	TSSOP-16
RS2259B	4	1:1	0.6	30	1.8	5.5	1	1.5	0.6	50	15	-40°C to 125°C	TSSOP-16
RS2233	4	1:2	3.0	220	2.5	5.5	1	2.0	0.5	30	13	-40°C to 85°C	TSSOP-16, SOIC16
RS2260	1	1:8	210	180	2.0	6.0	2	1.5	0.8	95	95	-40°C to 125°C	SOIC(SOP16),TSSOP-16,QFN3X3-16L
RS2268	4	1:1	4.5	300	1.8	5.5	4	1.5	0.5	30	25	-40°C to 85°C	TSSOP-14, SSOP-16

特殊开关系列 | Special Switch Series

Part Number	Feature	V _{CC} (Min) (V)	V _{CC} (Max) (V)	-3dB Bandwidth (MHz)	interface	R _{on} (Ω)	Crosstalk (-dB)	Package
RS550	Depletion 4 channels 1:1	0	3	200	I/O	0.5	-90	WLCS12,QFNWB3*3-16L
RS553	Depletion 2 channels 1:1	0	3	200	I/O	0.5	-85	WLCS12,DFN3*3-8L

RUNIC Technology Co.,Ltd provides customers with a series of low voltage analog switch, including a variety of single channel and multi-channel analog switch products, which has a low on-resistance (as low as 0.5 Ω), high speed, high performance, small packaging, rich selection etc., and can better meet customer demand.

线性稳压器【Linear Regulator】

江苏润石为客户提供了一系列高性能、低压差、宽范围线性稳压器产品，具有低噪声、低功耗、快速瞬态响应、优异的电压和负载调节能力、输入电压范围宽、输出电压选择多、小封装等特点，能够很好的满足客户的不同需求。

RUNIC Technology Co.,Ltd provides customers with a series of high performance, low dropout and wide range of linear regulator products, featuring low noise, low power consumption, fast transient response, excellent voltage and load regulation ability, wide range of input voltage, multiple choice of output voltage and small package, etc., which can better meet customers' different needs.

高压线性稳压器 | High Voltage Linear Regulator

Part Number	V _{IN} MIN (V)	V _{IN} MAX (V)	Output Current (mA)	Ground Current (No Load) (uA)	Dropout Voltage @I _{OUT} =1mA (mV)	PSRR @1kHz (dB)	Additional Feature Output current (mA)	V _{OUT} (V)	Operating Temperature Range (°C)	Package
RS3001	2.5	36	150	2.5	8	54	500	Adj	-40 to 85	SOT23-5
RS3002	2.5	36	150	2.5	8	54	—	1.8,2.5,3.0,3.3,3.6,5	-40 to 85	SOT23-5,SOT23,SOT23-3,SOT89-3
RS3003	6.3	36	150	11	—	63	—	3.0,3.3,5	-40 to 85	SOT89-3,SOT23-3
RS3005	2.5	36	150	11	8	63	—	3.0,3.3,3.6,4.0,5.0,5.5,Adj	-40 to 85	SOT89-3,SOT23-3,SOT23-5,SOT23
RS3007	2.5	45	300	3	3	77	—	1.8,2.5,3.0,3.3,5	-40 to 85	SOT23-3,SOT23-5,SOT89-3L,SOT223,SOIC-8
RS75xx-1	2.5	36	150	2	4.4	40	—	2.5,3.0,3.3,3.6,5.0	-40 to 85	SOT23-3,SOT89-3
RS73xx-1	2.5	45	300	3	3	77	—	1.8,2.5,3.0,3.3,3.6,5.0	-40 to 85	SOT23-3,SOT89-3

高精度线性稳压器 | High Precision Linear Regulator

Part Number	V _{OUT} (V)	V _{IN} (V)	Output Current (mA)	Dropout Voltage (mV)	Ground Current (No Load) (uA)	Output Voltage Noise (uV _{RMS})	PSRR @1kHz (dB)	Operating Temperature Range (°C)	Package
RS3219	1.2,1.5,1.8,2.5,2.8,3.0,3.3,Adj	1.7~7.5	300	280	120	38	55	-40 to 85	SOT23-3,SOT23-5,UTDFN1×1-4
RS3221	0.8,1.0,1.2,1.5,1.8,2.0,2.5,2.8,3.0,3.3,3.6,4.0,5.0,Adj	1.7~7.5	200	210	1	—	30	-40 to 85	SOT23-3,UTDFN1×1-4,SOT23-5,SC70-5,SOT89-3
RS3236	0.8,1.0,1.2,1.5,1.8,2.0,2.5,2.8,3.0,3.3,3.6,4.0,5.0,Adj	1.7~7.5	500	450	30	80	70	-40 to 85	UTDFN1×1-4,SOT23-5,SC70-5,SOT23-3,SOT89-3
RS3237*	1.2,1.8,2.5,2.8,3.0,3.3	1.7~7.5	250	210	20	15	90	-40 to 85	SOT23-5,UTDFN1×1-4
RS3238*	1.8,3.0,3.3,Adj	1.7~7.5	1000	280	90	50	75	-40 to 85	DFN 1.2*1.6-8L,DFN 3*3-8L
RS3239*	1.8,3.0,3.3,Adj	1.7~7.5	2000	500	500	80	70	-40 to 85	SOIC-8,DFN 3*3-8L

数据转换* 【Data Converter】

江苏润石为客户提供了系列化的数据转换器产品，主要包含12位至24位多通道高精度Delta-Sigma ADC，具有低功耗、高精度、自校准等特点，广泛应用于精密仪器仪表、医疗电子、汽车电子、人工智能、航天航空等领域。

RUNIC Technology Co.,Ltd provides customers with serialized data converter products, mainly including 12-bit to 24-bit multi-channel high-precision delta-sigma ADC with low power consumption, high precision and self-calibration, which are widely used in precision instruments, medical electronics, artificial intelligence, aerospace and other fields.

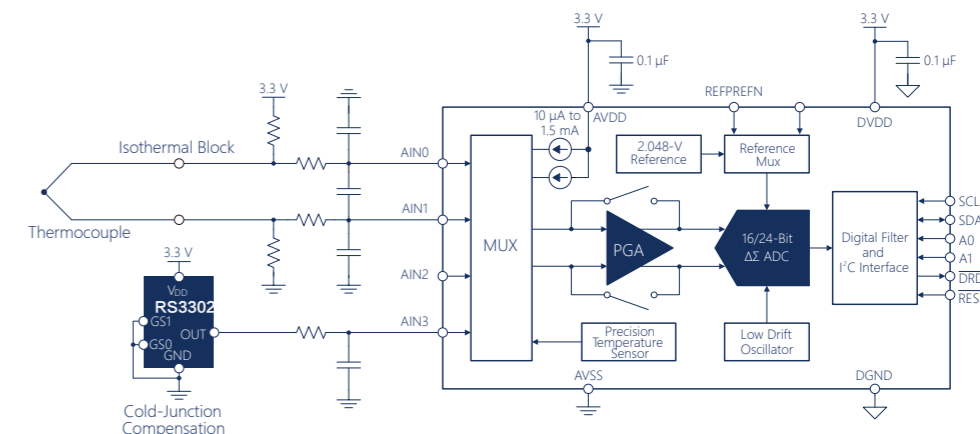

模数转换器 — 精密ADC | Analog-to-Digital Converter - Delta-Sigma ADC

Part Number	Resolution (Bits)	Sample Rate (max) (SPS)	# Input Channels	Multi-Channel Configuration	Interface	Integrated Features	Analog Voltage	Analog Voltage	Architecture	Operating Temperature Range (°C)	Description	Package
							AVDD (Min) (V)	AVDD (Max) (V)				
RS1259	24	14.4kSPS	1	N/A	SPI	50/60 Hz Rejection, Oscillator	4.75	5.25	Delta-Sigma	-40 to 105	24-Bit, 14.4kSPS, Delta-Sigma ADC	TSSOP
RS1240	24	15SPS	4	Multiplexed	SPI	50/60 Hz Rejection, GPIO, PGA	2.7	5.25	Delta-Sigma	-40 to 85	24-Bit ADC	SSOP
RS1241	24	15SPS	8	Multiplexed	SPI	50/60 Hz Rejection, GPIO, PGA	2.7	5.25	Delta-Sigma	-40 to 85	24-Bit ADC	SSOP
RS1246	24	2kSPS	1	N/A	SPI	50/60 Hz Rejection, Oscillator, PGA, Temp Sensor	2.7	5.25	Delta-Sigma	-40 to 105	24-Bit, 2kSPS, 2-Ch ADC	TSSOP
RS1247	24	2kSPS	4	Multiplexed	SPI	50/60 Hz Rejection, Excitation Current Sources (iDACs), GPIO, Oscillator, PGA, Temp Sensor	2.7	5.25	Delta-Sigma	-40 to 105	24-Bit, 2kSPS, 4-Ch ADC	TSSOP
RS1248	24	2kSPS	8	Multiplexed	SPI	50/60 Hz Rejection, Excitation Current Sources (iDACs), GPIO, Oscillator, PGA, Temp Sensor	2.7	5.25	Delta-Sigma	-40 to 105	24-Bit, 2kSPS, 8-Ch Delta-Sigma ADC	TSSOP
RS1234	24	80SPS	4	Multiplexed	SPI	50/60 Hz Rejection, Oscillator, PGA	2.7	5.3	Delta-Sigma	-40 to 105	24-Bit, Ultra-Low-Noise ADC	TSSOP
RS1232	24	80SPS	2	Multiplexed	SPI	50/60 Hz Rejection, Oscillator, PGA	2.7	5.3	Delta-Sigma	-40 to 105	24-Bit, Ultra-Low-Noise ADC	TSSOP
RS1231	24	80SPS	1	N/A	SPI	50/60 Hz Rejection, Oscillator	3	5.3	Delta-Sigma	-40 to 85	24-Bit, Low-Noise ADC	SOIC
RS1253	24	20kSPS	4	Multiplexed	SPI	50/60 Hz Rejection	4.75	5.25	Delta-Sigma	-40 to 85	24-Bit, 20kHz, Low-Power ADC	SSOP
RS1251	24	20kSPS	1	N/A	SPI	50/60 Hz Rejection	4.75	5.25	Delta-Sigma	-40 to 85	24-Bit, 20kHz, Low-Power ADC	SOIC
RS1220	24	2kSPS	4	Multiplexed	SPI	50/60 Hz Rejection, Excitation Current Sources (iDACs), Oscillator, PGA, Temp Sensor	2.3	5.5	Delta-Sigma	-40 to 125	24-Bit, 2kSPS, 4-Ch, Low-Power Delta-Sigma ADC	TSSOP, VQFN
RS1230	20	80SPS	1	N/A	SPI	50/60 Hz Rejection, Oscillator, PGA	2.7	5.3	Delta-Sigma	-40 to 85	20-Bit Delta-Sigma ADC for Bridge Sensors	TSSOP
RS1130	18	80SPS	1	N/A	—	50/60 Hz Rejection, Oscillator	2.7	5.3	Delta-Sigma	-40 to 85	18-Bit ADC for Bridge Sensors	TSSOP
RS1120	16	2kSPS	4	Multiplexed	SPI	50/60 Hz Rejection, Excitation Current Sources (iDACs), Oscillator, PGA, Temp Sensor	2.3	5.5	Delta-Sigma	-40 to 125	16-Bit 2kSPS 4-Ch Low-Power Delta-Sigma ADC	TSSOP, VQFN
RS1148	16	2kSPS	8	Multiplexed	SPI	50/60 Hz Rejection, Excitation Current Sources (iDACs), GPIO, Oscillator, PGA, Temp Sensor	2.7	5.25	Delta-Sigma	-40 to 105	16-Bit 2kSPS 8-Ch ADC With PGA	TSSOP, VQFN
RS1146	16	2kSPS	1	N/A	I2C	50/60 Hz Rejection, Oscillator, PGA, Temp Sensor	2.7	5.25	Delta-Sigma	-40 to 105	16-Bit 2kSPS 1-Ch ADC With PGA for Precision Sensor Measurement	TSSOP
RS1147	16	2kSPS	4	Multiplexed	I2C	50/60 Hz Rejection, Excitation Current Sources (iDACs), GPIO, Oscillator, PGA, Temp Sensor	2.7	5.25	Delta-Sigma	-40 to 105	16-Bit 2kSPS 4-Ch ADC With PGA for Precision Sensor Measurement	TSSOP
RS1100	16	128SPS	1	N/A	I2C	Oscillator, PGA	2.7	5.5	Delta-Sigma	-40 to 85	16-Bit, 128SPS, 1-Ch Delta-Sigma ADC	SOT23
RS1250	14	2MSPS	2	Multiplexed	SPI	2-Ch Single-ended inputs	2.7	5.25	SAR	-40 to 105	14-Bit ,2MSPS , 2-Ch Single-ended Input SAR ADC	QFN
RS1258	14	2MSPS	2	Multiplexed	SPI	2-Ch differential inputs	2.7	5.25	SAR	-40 to 105	14-Bit ,2MSPS , 2-Ch Differential Input SAR ADC	QFN
RS1257	12	1MSPS	1	N/A	SPI	1-Ch Single-ended inputs	2.7	5.25	SAR	-40 to 105	12-Bit ,1MSPS ,1-Ch SAR ADC	SOT23-6

逻辑 & 转换 【Logic & translation】

江苏润石针对 I/O 电压差异应用，推出自动双向电压转换器。

RUNIC Technology Co.,Ltd developed automatic bidirectional voltage converter for I / O voltage difference application.

电平转换器 | Level Converter

Part Number	Translators per Package	Data Rate (Mbps)	VCCA Range (V)	VCCB Range (V)	Bidirectional	VCC Shutdown I/O State	Icc Max (uA)	Shutdown Icc Max (uA)	Logic Output	Features	Package
RS0101	1	24/2	1.65~5.5	2.3~5.5	Yes	Hi-Z	11	1	Open-Drain/Push-Pull	GPIO Level Shifter	SOT23-6,SC70-6,DFN1.45*1.0-6L
RS0102	2	24/2	1.65~5.5	2.3~5.5	Yes	Hi-Z	13	1	Open-Drain/Push-Pull	GPIO Level Shifter	SOT23-8,DFN2x3-8L,DFN-1.4x1-8L,VSSOP8
RS0104	4	24/2	1.65~5.5	2.3~5.5	Yes	Hi-Z	15	1	Open-Drain/Push-Pull	GPIO Level Shifter	TSSOP-14,QFN2x2-12L,QFN2x1.7-12L,QFN3.5x3.5-14L
RS0108	8	24/2	1.65~5.5	2.3~5.5	Yes	Hi-Z	30	1	Open-Drain/Push-Pull	GPIO Level Shifter	TSSOP20 /QFN3x3-20L
RS0202	2	100	1.2~3.6	1.65~5.5	Yes	Hi-Z	15	1	Push-Pull	GPIO Level Shifter	SOT23-8,DFN2x3-8L,MSOP-8
RS0204	4	100	1.2~3.6	1.65~5.5	Yes	Hi-Z	20	1	Push-Pull	GPIO Level Shifter	TSSOP-14,QFN2x1.7-12L,QFN3.5x3.5-14L
RS0208	8	100	1.2~3.6	1.65~5.5	Yes	Hi-Z	30	1	Push-Pull	GPIO Level Shifter	TSSOP20 /QFN3x3-20L
RS0302	2	100	1.2~5.5	1.8~5.5	Yes	Hi-Z	15	1	Open-Drain	I2C & SMBus Level Shifter	SOT23-8,DFN1.4x1.0-8L
RS1T34	1	200	1.65~5.5	1.65~5.5	Yes	Hi-Z	10	1	Push-Pull	GPIO Level Shifter	SOT23-5,SC70-5
RS1T45	1	200	1.65~5.5	1.65~5.5	Yes	Hi-Z	10	1	Push-Pull	GPIO Level Shifter	SOT23-6,SC70-6
RS2T45	2	200	1.65~5.5	1.65~5.5	Yes	Hi-Z	10	1	Push-Pull	GPIO Level Shifter	SOT23-8,VSSOP-8,MSOP-8
RS2T245	2	200	0.9~3.6	0.9~3.6	Yes	Hi-Z	30	1	Push-Pull	GPIO Level Shifter	QFN-10L
RS4T245	4	200	1.65~5.5	1.65~5.5	Yes	Hi-Z	50	1	Push-Pull	GPIO Level Shifter	TSSOP-16,QFN-16L
RS4T774	4	200	0.9~3.6	0.9~3.6	Yes	Hi-Z	30	1	Push-Pull	GPIO Level Shifter	TSSOP-16,QFN-16L
RS8T245	8	200	1.65~5.5	1.65~5.5	Yes	Hi-Z	50	1	Push-Pull	GPIO Level Shifter	TSSOP-24,SOIC-24

小逻辑 | Small Logic Series

Part Number	Translators per Package	VCC Range (V)	Icc Max (uA)	Operating Temperature Range (°C)	Features	Package
RS1G00	1	1.65~5.5	10	-40 to 125	Single Channel 2-Input NAND Gate	SOT23-5,SC70-5
RS2G00	2	1.65~5.5	10	-40 to 125	Dual Channel 2-Input NAND Gate	MSOP-8
RS4G00	4	1.65~5.5	10	-40 to 125	Quad Channel 2-Input NAND Gate	SOIC-14
RS1G04	1	1.65~5.5	10	-40 to 125	Single Channel Inverter	SOT23-5,SC70-5
RS2G04	2	1.65~5.5	10	-40 to 125	Dual Channel Inverter	SOT23-6,SC70-6
RS3G04	3	1.65~5.5	10	-40 to 125	Triple Channel Inverter	MSOP-8,DFN1.4x1.0-8L
RS6G04	6	1.65~5.5	10	-40 to 125	Hex Channel Inverter	SOIC-14, TSSOP-14

小逻辑 | Small Logic Series

Part Number	Translators per Package	VCC Range (V)	Icc Max (uA)	Operating Temperature Range (°C)	Features	Pacakage
RS1G06	1	1.65~5.5	10	-40 to 125	Single Channel Inverter with open drain output	SOT23-5,SC70-5
RS1G07	1	1.65~5.5	10	-40 to 125	Single Channel Non-inverting Buffer with Open-drain Output	SOT23-5,SC70-5
RS2G07	2	1.65~5.5	10	-40 to 125	Dual Channel Non-inverting Buffer with Open-drain Output	SOT23-6,SC70-6
RS6G07	6	1.65~5.5	10	-40 to 125	Hex Channel Non-inverting Buffer with Open-drain Output	SOIC-14, TSSOP-14
RS1G08	1	1.65~5.5	10	-40 to 125	Single Channel 2-Input AND Gate	SOT23,SOT23-5,SC70-5
RS2G08	2	1.65~5.5	10	-40 to 125	Dual Channel 2-Input AND Gate	MSOP-8
RS4G08	4	1.65~5.5	10	-40 to 125	Quad Channel 2-Input AND Gate	SOIC-14, TSSOP-14
RS1G14	1	1.65~5.5	10	-40 to 125	Single Channel Schmitt-Trigger Inverter	SOT23-5,SC70-5
RS2G14	2	1.65~5.5	10	-40 to 125	Dual Channel Schmitt-Trigger Inverter	SOT23-6,SC70-6
RS3G14	3	1.65~5.5	10	-40 to 125	Triple Channel Schmitt-Trigger Inverter	MSOP-8, DFN1.4x1.0-8L
RS6G14	6	1.65~5.5	10	-40 to 125	Hex Channel Schmitt-Trigger Inverter	SOIC-14, TSSOP-14
RS1G17	1	1.65~5.5	10	-40 to 125	Single Channel Non-inverting Buffer	SOT23-5,SC70-5,DFN1x1-6L
RS2G17	2	1.65~5.5	10	-40 to 125	Dual Channel Non-inverting Buffer	SOT23-6,SC70-6
RS6G17	6	1.65~5.5	10	-40 to 125	Hex Channel Non-inverting Buffer	SOIC-14
RS1G32	1	1.65~5.5	10	-40 to 125	Single Channel 2-input OR Gate	SOT23-5,SC70-5
RS2G32	2	1.65~5.5	10	-40 to 125	Dual Channel 2-input OR Gate	MSOP-8
RS4G32	4	1.65~5.5	10	-40 to 125	Quad Channel 2-input OR Gate	SOIC-14
RS1G86	1	1.65~5.5	10	-40 to 125	Single Channel 2-input Exclusive-OR Gate	SOT23-5,SC70-5
RS2G86	2	1.65~5.5	10	-40 to 125	Dual Channel 2-input Exclusive-OR Gate	MSOP-8
RS4G86	4	1.65~5.5	10	-40 to 125	Quad Channel 2-input Exclusive-OR Gate	SOIC-14
RS1G125	1	1.65~5.5	10	-40 to 125	Single Active-Low Bus Buffer Gate With 3-State Output	SOT23-5,SC70-5
RS2G125	2	1.65~5.5	10	-40 to 125	Dual Active-Low Bus Buffer Gate With 3-State Output	TSSOP-8
RS4G125	4	1.65~5.5	10	-40 to 125	Quad Active-Low Bus Buffer Gate With 3-State Output	SOIC-14
RS1G126	1	1.65~5.5	10	-40 to 125	Single Active-High Bus Buffer Gate With 3-State Output	SOT23-5,SC70-5
RS2G126	2	1.65~5.5	10	-40 to 125	Dual Active-High Bus Buffer Gate With 3-State Output	TSSOP-8
RS4G126	4	1.65~5.5	10	-40 to 125	Quad Active-High Bus Buffer Gate With 3-State Output	SOIC-14
RS244	8	1.8~5.5	50	-40 to 125	Octal Buffer/Driver With 3-State Outputs	TSSOP-20,SOIC-20
RS245	8	1.8~5.5	50	-40 to 125	Octal Bus Transceivers With 3-State Outputs	TSSOP-20,SOIC-20

电压基准源芯片 【Voltage Reference】

江苏润石为客户提供了一系列不同精度、不同电压的电压基准源芯片，广泛用于医疗仪器、仪表、电源、工业控制、汽车电器等领域。

RUNIC Technology Co.,Ltd provides customers with a series of reference voltage source chips with different precision and voltage, which are widely used in medical instruments, meters, power supply, industrial control, automotive appliances and other fields.

并联电压基准源 | Shunt Voltage Reference

Part Number	VREF (V)	Voltage Tolerance	VKA (V)	IREF (Max, uA)	IKA (Min, mA)	Temperature	Operating	Pacakage
RS431	2.5	0.5% / 1%	2.5~36	4	0.5	50ppm/°C	-40 to 150	SOT23
RS432	2.5	0.5% / 1%	2.5~36	4	0.5	50ppm/°C	-40 to 150	SOT23
RS421	1.18	0.50%	1.25~36	4	0.5	50ppm/°C	-40 to 150	SOT23
RS422	1.18	0.50%	1.25~36	4	0.5	50ppm/°C	-40 to 150	SOT23

负载开关 【Load Switches】

江苏润石为客户提供了一系列高检测精度、不同限制电流的负载开关芯片，广泛用于医疗仪器、PC、TV&STB、工业控制等领域。

RUNIC Technology Co.,Ltd provides customers with a series of load switch chips with high detection accuracy and different limiting current, which are widely used in medical instruments, PC, TV & STB, industrial control and other fields.

Part Number	Continuous Output Current (mA)	Quiescent Current (uA)	VIN Min(V)	VIN Max(V)	Enable Logic	Shutdown Current (uA)	Current Limit (mA)	Soft-Start	Fault Flag	Pacakage
RS2580	6000	35	0.8	5.5	High	0.1	6000	Yes	No	DFN2x2-8L
RS2581*	2500	30	2.5	5.5	High	0.1	100 to 2500	Yes	No	SOT23-5
RS2582*	2500	30	2.5	5.5	High	0.1	100 to 2500	Yes	No	SOT23-5
RS2583*	2500	30	2.5	5.5	High	0.1	100 to 2500	Yes	Yes	SOT23-6
RS2584*	1000/2100	5	2.1	5.5	High	1	1000/2100	Yes	No	SOT23-5
RS2585*	1000	5	1	5.5	High	1	1000	Yes	No	CSP0.8x0.8-4L
RS2586*	3000	10	2.1	5.5	High	1	3000	Yes	No	CSP1.4x0.9-6L/DFN2x2-6L
RS2588	1000/2000/2500	30	2.5	5.5	High	0.1	1100/2100/2600	Yes	Yes	SOT23-5
RS2599	3000	100	2.5	5.5	High	0.1	500 to 3000	Yes	Yes	DFN3x3-8L

DC/DC

江苏润石为客户提供了一系列DC-DC转换器件，功耗低，可用于医疗仪器、TV&STB、工业控制、智能穿戴、物联网等领域。

Part Number	DC-DC Topology	Output Current Max (mA)	Quiescent Current (uA)	VIN Min(V)	VIN Max(V)	Efficiency Max	Output Voltage	Switching Frequency (MHz)	Shutdown Current (uA)	Enable Logic	Pacakage
RS6651	Sync Boost	1000	20	2.2	4.5	95%	3.0~5.5V	1.1	1	High	TSOT23-6
RS6699*	Sync Boost	600	2	1	5.5	90%	1.8~5.5V	1.2	1	High	SOT23-6,DFN2x2-6L

RUNIC Technology Co.,Ltd provides customers with a series of DC-DC converters with low power consumption, which can be used in medical instruments, TV & STB, industrial control, intelligent wearable, Internet of things and other fields.

电压检测和复位 [Supervisory Circuit]

电压检测和复位系列芯片包括看门狗计时器、带手动复位功能的复位芯片、电压检测、固定延时时间或者可设置延时时间的复位芯片，以超低的系统功耗持续监控系统运行，广泛用于医疗仪器、TV&STB、工业控制、智能穿戴、物联网等领域。

Part Number	Quiescent Current (uA)	Manual Reset	Vcc (V)	Detect Threshold	Watchdog Timer	Vcc to Reset Delay (us)	Reset Active Timeout Period (ms)	Reset Output	Pacakage
RS706	20	Yes	1.0~5.5	2.63,2.93,3.08,4.0	1.6s	30	200	Low	SOIC-8
RS802*	5	No	1.0~5.5	1.63,2.32,2.63,2.93	No	100	ADJ	High	SC70-4,SOT143
RS803	2	No	1.0~5.5	1.63,2.63,2.93,3.08,4.4	No	50	200	Low	SOT23-3
RS804*	5	No	1.0~5.5	1.63,2.32,2.63,2.93	No	100	ADJ	Low	SC70-4,SOT143
RS806	20	Yes	1.0~5.5	2.63,2.93,3.08,4.0	1.6s	30	200	Low	SOT23-5
RS809	2	No	1.0~5.5	1.63,2.63,2.93,3.08,4.4	No	50	200	Low	SOT23-3
RS810*	2	No	1.0~5.5	1.63,2.63,2.93,3.08,4.4	No	50	200	High	SOT23-3
RS811*	15	Yes	1.0~5.5	2.63,2.93,3.08,4.4	No	50	200	Low	SOT143

The series of voltage detection and reset chips include watchdog timer, reset chip with manual reset function, voltage detection, reset chip with fixed delay time or set delay time. They are widely used in medical instruments, TV & STB, industrial control, intelligent wearable, Internet of things and other fields with ultra-low system power consumption.

马达驱动* [Motor Driver]

Part Number	Motor Type	RMS Output Current (A)	Peak Output Current (A)	VCC/VM Min(V)	VCC/VM Max(V)	Control Interface	RDS(ON) (HS+LS) (mΩ)	Operating Temperature	Pacakage
RS8835	Brushed DC Motor	1.8	3.5	1.8	7	PWM	500	-40°C~125°C	SOT23-6
RS8837	Brushed DC Motor	1.8	3.5	0	12	PWM	500	-40°C~125°C	SOIC-8,DFN2x2-8L