

150mA, Low Power Consumption, High Voltage CMOS LDO Regulator

1 FEATURES

- **Input Voltage Range: 2.5 V to 36 V**
- **Output Voltage Range:**
- **Fixed Option: 1.8V, 2.5V, 3.0V, 3.3V, 3.6V, 4.1V, 4.4V, 5.0V, 9.0V and 12.0V**
- **Very Low I_Q: 1.9μA (TYP)**
- **Up to 150mA Load Current**
- **Low Dropout Voltage**
- **Low Temperature Coefficient**
- **Short Circuit Protection is Typical 35mA**
- **Output Voltage Accuracy: ±2%**
- **SOT23, SOT23-5 and SOT89-3 Packages**

2 APPLICATIONS

- **Smart Power Network Equipment**
- **Portable Power Tools**
- **BMS Systems**
- **Motor Control System/Industrial Control System**
- **Power Meter/Instrument**
- **White Goods**
- **Vehicle-Mounted System**
- **Battery-Powered Equipment**
- **Automotive Head Unit**
- **Security Equipment**
- **Communication Equipment**

3 DESCRIPTIONS

The RS3004 series are a group of positive voltage regulators manufactured by CMOS technologies with low power consumption and low dropout voltage, which provide large output currents even with a small input-output voltage difference. The RS3004 series can deliver 150mA output current and allow input voltages up to 36V. The series are very suitable for the battery-powered equipment, such as RF applications and other systems requiring a quiet voltage source.

The RS3004 is available in Green SOT23, SOT23-5 and SOT89-3 variety of packages, for the different application's requirements.

Device Information (1)

PART NUMBER	PACKAGE	BODY SIZE (NOM)
RS3004	SOT23	1.30mm×2.92mm
	SOT23-5	1.60mm×2.92mm
	SOT89-3	2.45mm×4.50mm

(1) For all available packages, see the orderable addendum at the next page of the data sheet.

4 TYPICAL APPLICATION SCHEMATIC

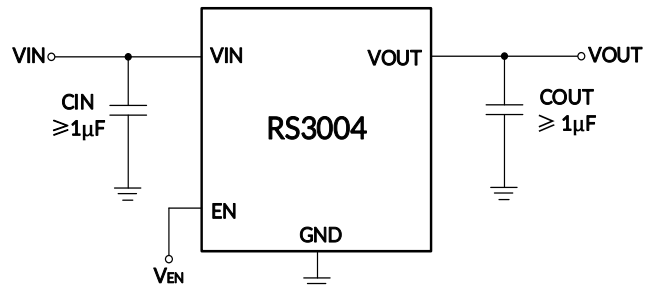

5 FUNCTIONAL BLOCK DIAGRAM

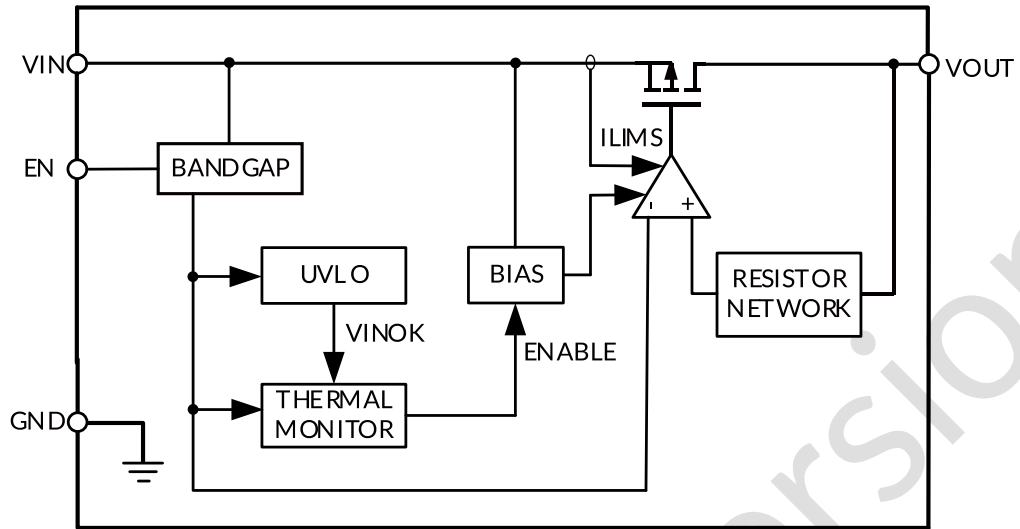

Preliminary version

Table of Contents

1 FEATURES	1
2 APPLICATIONS	1
3 DESCRIPTIONS	1
4 TYPICAL APPLICATION SCHEMATIC	1
5 FUNCTIONAL BLOCK DIAGRAM	2
6 REVISION HISTORY	4
7 PACKAGE/ORDERING INFORMATION ⁽¹⁾	5
8 PIN CONFIGURATION AND FUNCTIONS	7
9 SPECIFICATIONS	8
9.1 Absolute Maximum Ratings	8
9.2 ESD Ratings	8
9.3 Recommended Operating Conditions	8
9.4 Electrical Characteristics	9
9.5 Typical Characteristics	11
10 DETAILED DESCRIPTION	17
10.1 Overview	17
10.2 Under Voltage Lockout (UVLO)	17
10.3 Shutdown	17
10.4 Thermal Overload Protection (T _{SD})	17
10.5 Disabled	17
10.6 Current-Limit Protection	17
10.7 Short Current-Limit Protection	17
10.8 Input and Output Capacitor Requirements	17
11 POWER SUPPLY RECOMMENDATIONS	18
12 LAYOUT	18
13 PACKAGE OUTLINE DIMENSIONS	19
14 TAPE AND REEL INFORMATION	22

6 REVISION HISTORY

Note: Page numbers for previous revisions may differ from page numbers in the current version.

VERSION	Change Date	Change Item
A.0	2025/04/30	Preliminary version completed
A.0.1	2026/03/03	1. Add RS3004-3.3XTF5-G, RS3004-5.0XTF5-G, RS3004-4.4XE3L ORDERING INFORMATION 2. Update SPECIFICATIONS
A.0.2	2026/06/04	Add the θ_{JA} values for SOT23 and SOT23-5 packages in Absolute Maximum Ratings

Preliminary version

7 PACKAGE/ORDERING INFORMATION (1)

PRODUCT	ORDERING NUMBER (2)	V _{OUT} (V)	PACKAGE LEAD	PACKAGE MARKING (3)	MSL (4)	PACKAGE OPTION
RS3004-1.8	RS3004-1.8XSF3	1.8	SOT23	SK18	MSL3	Tape and Reel, 3000
	RS3004-1.8XF5	1.8	SOT23-5	SK18	MSL3	Tape and Reel, 3000
	RS3004-1.8XSF5	1.8	SOT23-5(S-Type)	SK18S	MSL3	Tape and Reel, 3000
RS3004-3.0	RS3004-3.0XSF3	3.0	SOT23	SK30	MSL3	Tape and Reel, 3000
	RS3004-3.0XF5	3.0	SOT23-5	SK30	MSL3	Tape and Reel, 3000
	RS3004-3.0XE3	3.0	SOT89-3	SK30	MSL3	Tape and Reel, 1000
	RS3004-3.0XSF5	3.0	SOT23-5(S-Type)	SK30S	MSL3	Tape and Reel, 3000
	RS3004-3.0XE3L	3.0	SOT89-3(L-Type)	SK30L	MSL3	Tape and Reel, 1000
RS3004-3.3	RS3004-3.3XSF3	3.3	SOT23	SK33	MSL3	Tape and Reel, 3000
	RS3004-3.3XF5	3.3	SOT23-5	SK33	MSL3	Tape and Reel, 3000
	RS3004-3.3XSF5	3.3	SOT23-5(S-Type)	SK33S	MSL3	Tape and Reel, 3000
	RS3004-3.3XTF5	3.3	SOT23-5(T-Type)	SK33T	MSL3	Tape and Reel, 3000
	RS3004-3.3XTF5-G	3.3	SOT23-5(T-Type)	SK33T	MSL1	Tape and Reel, 3000
	RS3004-3.3XE3	3.3	SOT89-3	SK33	MSL3	Tape and Reel, 1000
	RS3004-3.3XE3L	3.3	SOT89-3(L-Type)	SK33L	MSL3	Tape and Reel, 1000
RS3004-3.6	RS3004-3.6XF5	3.6	SOT23-5	SK36	MSL3	Tape and Reel, 3000
	RS3004-3.6XSF5	3.6	SOT23-5(S-Type)	SK36S	MSL3	Tape and Reel, 3000
	RS3004-3.6XE3	3.6	SOT89-3	SK36	MSL3	Tape and Reel, 1000
	RS3004-3.6XE3L	3.6	SOT89-3(L-Type)	SK36L	MSL3	Tape and Reel, 1000
RS3004-4.1	RS3004-4.1XSF5	4.1	SOT23-5(S-Type)	SK41S	MSL3	Tape and Reel, 3000
RS3004-4.4	RS3004-4.4XSF5	4.4	SOT23-5(S-Type)	SK44S	MSL3	Tape and Reel, 3000
	RS3004-4.4XE3L	4.4	SOT89-3(L-Type)	SK44L	MSL3	Tape and Reel, 1000
RS3004-5.0	RS3004-5.0XSF3	5.0	SOT23	SK50	MSL3	Tape and Reel, 3000
	RS3004-5.0XF5	5.0	SOT23-5	SK50	MSL3	Tape and Reel, 3000
	RS3004-5.0XSF5	5.0	SOT23-5(S-Type)	SK50S	MSL3	Tape and Reel, 3000
	RS3004-5.0XTF5	5.0	SOT23-5(T-Type)	SK50T	MSL3	Tape and Reel, 3000
	RS3004-5.0XTF5-G	5.0	SOT23-5(T-Type)	SK50T	MSL1	Tape and Reel, 3000
	RS3004-5.0XE3	5.0	SOT89-3	SK50	MSL3	Tape and Reel, 1000
	RS3004-5.0XE3L	5.0	SOT89-3(L-Type)	SK50L	MSL3	Tape and Reel, 1000
RS3004-9.0	RS3004-9.0XSF3	9.0	SOT23	SK90	MSL3	Tape and Reel, 3000
	RS3004-9.0XF5	9.0	SOT23-5	SK90	MSL3	Tape and Reel, 3000
	RS3004-9.0XSF5	9.0	SOT23-5(S-Type)	SK90S	MSL3	Tape and Reel, 3000
	RS3004-9.0XE3	9.0	SOT89-3	SK90	MSL3	Tape and Reel, 1000
	RS3004-9.0XE3L	9.0	SOT89-3(L-Type)	SK90L	MSL3	Tape and Reel, 1000
RS3004-12.0	RS3004-12.0XSF3	12.0	SOT23	SKA0	MSL3	Tape and Reel, 3000
	RS3004-12.0XF5	12.0	SOT23-5	SKA0	MSL3	Tape and Reel, 3000
	RS3004-12.0XSF5	12.0	SOT23-5(S-Type)	SKA0S	MSL3	Tape and Reel, 3000
	RS3004-12.0XE3	12.0	SOT89-3	SKA0	MSL3	Tape and Reel, 1000
	RS3004-12.0XE3L	12.0	SOT89-3(L-Type)	SKA0L	MSL3	Tape and Reel, 1000

NOTE:

(1) This information is the most current data available for the designated devices. This data is subject to change without notice and revision of this document. For browser-based versions of this data sheet, refer to the right-hand navigation.

(2) RS3004-□□□X□□□

Package Type

SF3: SOT23
F5: SOT23-5
SF5: SOT23-5 (S-Type)
TF5: SOT23-5 (T-Type)
E3: SOT89-3
E3L: SOT89-3 (L-Type)

Output Voltage

1.8: 1.8V
2.5: 2.5V
3.0: 3.0V
3.3: 3.3V
3.6: 3.6V
4.1: 4.1V
4.4: 4.4V
5.0: 5.0V
9.0: 9.0V
12.0: 12.0V

*Special Request: Any Voltage between 1.8V and 12V under specific business agreement

(3) There may be additional marking, which relates to the lot trace code information (data code and vendor code), the logo or the environmental category on the device.

(4) Runic classify the MSL level with using the common preconditioning setting in our assembly factory conforming to the JEDEC industrial standard J-STD-20F. Please align with Runic if your end application is quite critical to the preconditioning setting or if you have special requirement.

8 PIN CONFIGURATION AND FUNCTIONS

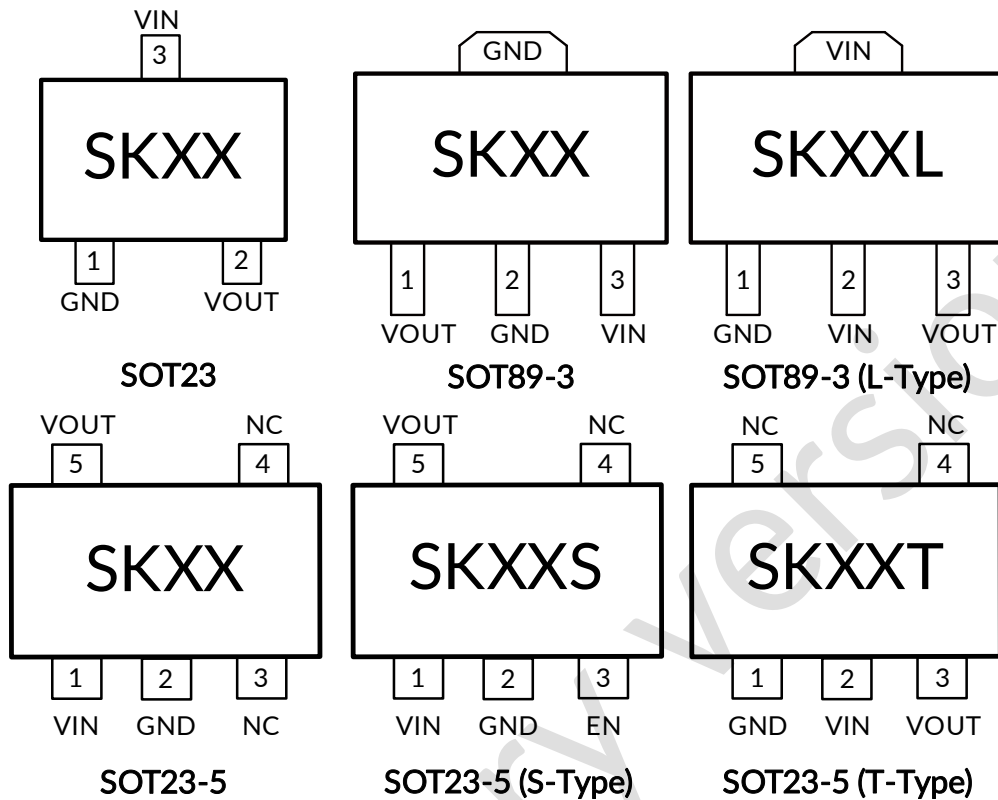

NOTE: XX indicate Output Voltage, xx indicate Date Code
For example: SK33 (V_{OUT}=3.3V)

PIN DESCRIPTION

NAME	PIN						I/O ⁽¹⁾	FUNCTION
	SOT23	SOT89-3	SOT89-3 (L-Type)	SOT23-5	SOT23-5 (S-Type)	SOT23-5 (T-Type)		
GND	1	2	1	2	2	1	G	Ground.
VOUT	2	1	3	5	5	3	O	Regulated output voltage. Connect a minimum 1 μ F low-ESR capacitor to this pin.
VIN	3	3	2	1	1	2	I	Input voltage supply. Must be closely decoupled to GND with a 1 μ F or greater capacitor.
EN	-	-	-	-	3	-	I	Enable input. A low voltage (< V _{IL}) on this pin turns the regulator off. A high voltage (> V _{IH}) on this pin enables the regulator output. The EN pin can be connected to the VIN pin if not used. Do not leave floating.
NC	-	-	-	3/4	4	4/5	-	No internal connection

(1) I = Input, O = Output, G=Ground.

9 SPECIFICATIONS

9.1 Absolute Maximum Ratings

over operating free-air temperature range (unless otherwise noted) ^{(1) (2)}

		MIN	MAX	UNIT
V _{IN}	Input voltage	-0.3	40	V
V _{EN}	V _{EN} voltage range	-0.3	40	V
V _{OUT}	V _{OUT} voltage range	-0.3	13	V
T _J	PN Junction temperature ⁽³⁾	-40	150	°C
P _D	Continuous power dissipation ⁽⁴⁾	Internally limited		W
θ _{JA}	Package thermal impedance ⁽⁵⁾	SOT23	230	°C/W
		SOT23-5 (T-Type)	220	
		SOT23-5 (S-Type)	160	
		SOT23-5	160	
		SOT89-3	105	
		SOT89-3(L-Type)	135	
T _{stg}	Storage temperature range	-65	150	°C
T _{solder}	Lead Temperature (Soldering, 10 sec)		260	°C

- (1) Stresses beyond those listed under Absolute Maximum Ratings may cause permanent damage to the device. These are stress ratings only, and functional operation of the device at these or any other conditions beyond those indicated under Recommended Operating Conditions is not implied. Exposure to absolute-maximum-rated conditions for extended periods may affect device reliability.
- (2) All voltages are with respect to the GND pin.
- (3) The maximum power dissipation is a function of T_{J(MAX)}, R_{θJA}, and T_A. The maximum allowable power dissipation at any ambient temperature is P_D = (T_{J(MAX)} - T_A) / R_{θJA}. All numbers apply for packages soldered directly onto a PCB.
- (4) Internal thermal shutdown circuitry protects the device from permanent damage. The actual chip output current is subject to the input-output voltage difference, ambient temperature and PCB heat dissipation design.
- (5) The package thermal impedance is calculated in accordance with JESD-51.

9.2 ESD Ratings

The following ESD information is provided for handling of ESD-sensitive devices in an ESD protected area only.

		VALUE	UNIT
V _(ESD)	Electrostatic discharge	Human-Body Model (HBM), MIL-STD-883K METHOD 3015.9	±2000
		Charge Device Model (CDM), ANSI/ESDA/JEDEC JS-002-2022	±1000



ESD SENSITIVITY CAUTION

ESD damage can range from subtle performance degradation to complete device failure. Precision integrated circuits may be more susceptible to damage because very small parametric changes could cause the device not to meet its published specifications.

9.3 Recommended Operating Conditions

over operating free-air temperature range (unless otherwise noted)

		MIN	MAX	UNIT
V _{IN}	Input Voltage Range on VIN	2.5	36	V
V _{OUT}	Output Voltage Range on VOUT	1.8	12	V
I _{OUT}	Output Current Range on IOUT	1	150	mA
C _{OUT}	Capacitor of V _{OUT} pin	1	47	μF
T _J	PN Junction temperature	-40	125	°C

9.4 Electrical Characteristics

Over operating temperature range ($-40^{\circ}\text{C} \leq T_J \leq 125^{\circ}\text{C}$), $V_{IN} = V_{OUTnom} + 2\text{V}$ ⁽¹⁾, $C_{IN} = C_{OUT} = 1\mu\text{F}$, $V_{OUT}=3.3\text{V}$, $I_{OUT}=1\text{mA}$, unless otherwise noted. Typical values are at $T_A = 25^{\circ}\text{C}$.

PARAMETER	SYMBOL	CONDITIONS	MIN ⁽²⁾	TYP ⁽³⁾	MAX ⁽²⁾	UNIT
POWER SUPPLY AND CURRENTS						
Input Voltage ⁽¹⁾	V_{IN}		2.5		36	V
Under Voltage Lockout	UVLO	V_{IN} rising		2.25		V
Hysteresis	V_{HYS}	V_{IN} falling		50		mV
Quiescent Current	I_Q	$V_{IN} = V_{OUTnom} + 2\text{V}$, $I_{OUT} = 0\text{mA}$		1.9		μA
		$V_{IN} = 36\text{V}$, $I_{OUT} = 0\text{mA}$		2.3		
Ground Pin Current	I_{GND}	$I_{OUT} = 150\text{mA}$		550		μA
Shutdown Current	I_{SD}	$V_{EN}=0\text{V}$, $V_{IN}=36\text{V}$		0.4	1	μA
OUTPUT VOLTAGE						
Output Voltage Range	V_{OUT}		1.8		12	V
DC Output Accuracy ⁽¹⁾	ΔV_{OUT}	$T_J = 25^{\circ}\text{C}$, $I_{OUT} = 1\text{mA}$		± 2		%
Line Regulation ⁽¹⁾	$\Delta V_{OUT}(\Delta V_{IN})$	$V_{IN} = V_{OUT} + 2\text{V}$ to 36V , $I_{OUT} = 1\text{mA}$		0.001		%/V
Load Regulation ⁽¹⁾	$\Delta V_{OUT}(\Delta I_{OUT})$	$V_{IN} = V_{OUT} + 2\text{V}$, $I_{OUT} = 1\text{mA}$ to 150mA		20		mV
Output Voltage Temperature Coefficient ⁽⁴⁾	$\frac{\Delta V_{OUT}}{\Delta T_A \times V_{OUT}}$	$I_{OUT} = 1\text{mA}$, $T_J = -40^{\circ}\text{C} \sim 85^{\circ}\text{C}$		85		ppm/ $^{\circ}\text{C}$
		$I_{OUT} = 1\text{mA}$, $T_J = -40^{\circ}\text{C} \sim 125^{\circ}\text{C}$		70		ppm/ $^{\circ}\text{C}$
Maximum output current ⁽⁵⁾	I_{OUTMAX}	$V_{IN} > 3.6\text{V}$ or $V_{out} + V_{DO}$, whichever is greater	150			mA
DROPOUT VOLTAGE						
Dropout Voltage ⁽⁶⁾	V_{DO}	$I_{OUT} = 150\text{mA}$	$V_{OUT}=1.8\text{V}$		1450	mV
			$V_{OUT}=3.0\text{V}$		1050	
			$V_{OUT}=3.3\text{V}$		1000	
			$V_{OUT}=5.0\text{V}$		850	
			$V_{OUT}=9.0\text{V}$		750	
			$V_{OUT}=12.0\text{V}$		750	
POWER SUPPLY REJECTION RATIO AND NOISE						
Power Supply Rejection Ratio ⁽⁷⁾	PSRR	$V_{IN}=5.3\text{V}$, $V_{OUT} = 3.3\text{V}$, $I_{OUT} = 50\text{mA}$	$f = 100\text{Hz}$		65	dB
			$f = 1\text{KHz}$		65	dB
			$f = 100\text{KHz}$		49	dB
			$f = 1\text{MHz}$		45	dB
Output Noise Voltage ⁽⁷⁾	V_N	$\text{BW} = 10\text{Hz} \sim 100\text{KHz}$, $V_{OUT} = 3.3\text{V}$, $I_{OUT} = 100\text{mA}$		135		μV_{RMS}
ENABLE AND STARTUP TIME						
EN Input Logic High Voltage	V_{IH}	$V_{IN} = 2.5\text{V}$ to 36V , EN rising	1.2			V
EN Input Logic Low Voltage	V_{IL}	$V_{IN} = 4.3\text{V}$ to 36V , EN falling			0.4	V
	$V_{IL,2.5}$	$V_{IN} = 2.5\text{V}$ to 4.3V , EN falling			0.2	V
EN Input leakage current	I_{EN}	$V_{IN}=36\text{V}$, $V_{EN} = 0\text{V}$			1	μA
		$V_{IN}=36\text{V}$, $V_{EN} = 36\text{V}$			1	μA
PROTECTIONS						
Over Current Limit	I_{LMT}	$V_{OUT} = 0.8 \times V_{OUTnom}$	200	400		mA
Short-circuit current limit	I_{SC}	$V_{OUT}=0\text{V}$		35		mA
Thermal shutdown threshold ⁽⁷⁾	T_{TSD}	T_J rising		150		$^{\circ}\text{C}$

Thermal shutdown hysteresis ⁽⁷⁾	T _{HYS}	T _J falling from shutdown		25		°C
--	------------------	--------------------------------------	--	----	--	----

NOTE:

- (1) Minimum $V_{IN} = V_{OUT} + V_{DO}$ or 2.5V, whichever is greater.
- (2) Limits are 100% production tested at 25°C. Limits over the operating temperature range are ensured through correlations using statistical quality control (SQC) method.
- (3) Typical values represent the most likely parametric norm as determined at the time of characterization. Actual typical values may vary over time and will also depend on the application and configuration.
- (4) Output voltage temperature coefficient is defined as the worst-case voltage change divided by the total temperature range.
- (5) Maximum output current is affected by the PCB layout, size of metal trace, the thermal conduction path between metal layers, ambient temperature and the other environment factors of system. Attention should be paid to the dropout voltage when $V_{IN} < V_{OUT} + V_{DROP}$.
- (6) The dropout voltage is defined as $V_{IN} - V_{OUT}$, when V_{OUT} is 2% below the value of V_{OUT} for $V_{IN} = V_{OUTnom} + 2V$.
- (7) Guaranteed by design and characterization, not a FT item.

Preliminary version

9.5 Typical Characteristics

NOTE: The graphs and tables provided following this note are a statistical summary based on a limited number of samples and are provided for informational purposes only.

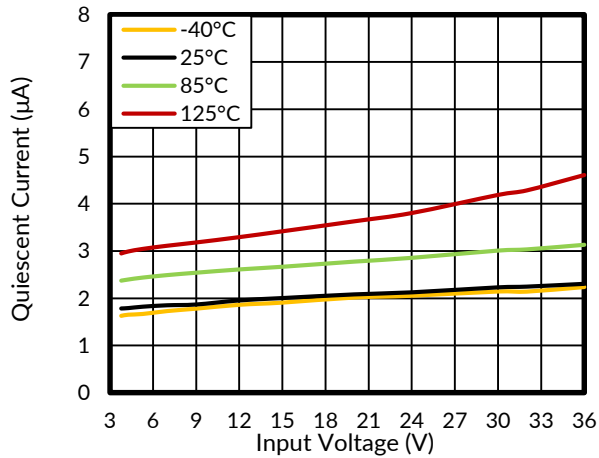

Figure 1. Quiescent Current vs Input Voltage

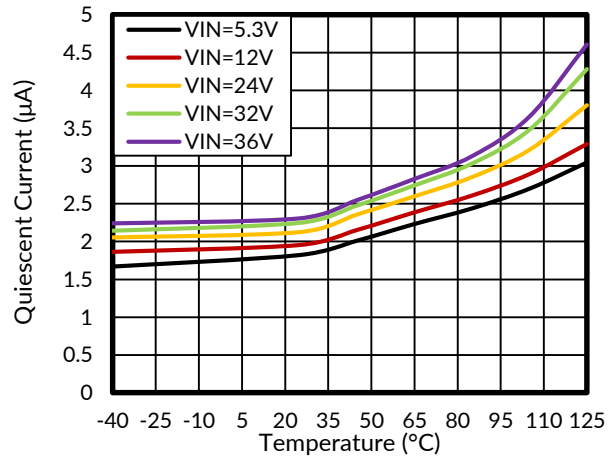

Figure 2. Quiescent Current vs Temperature

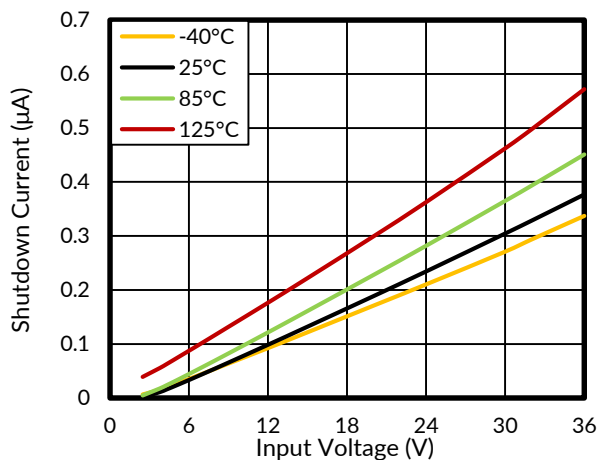

Figure 3. Shutdown Current vs Input Voltage

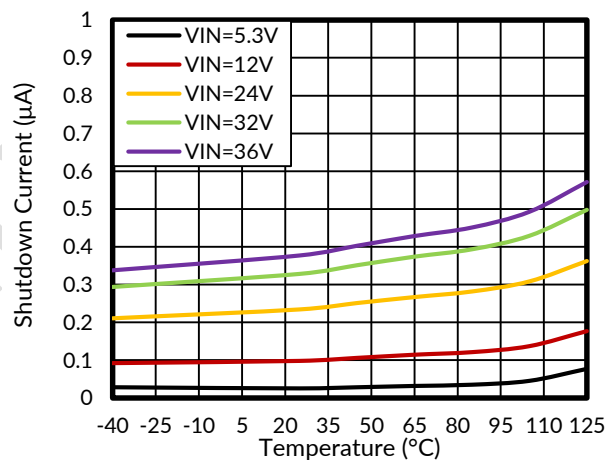

Figure 4. Shutdown Current vs Junction Temperature

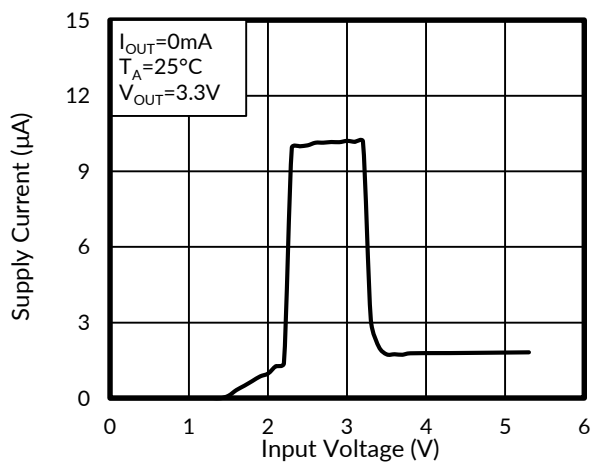

Figure 5. Supply Current vs Input Voltage

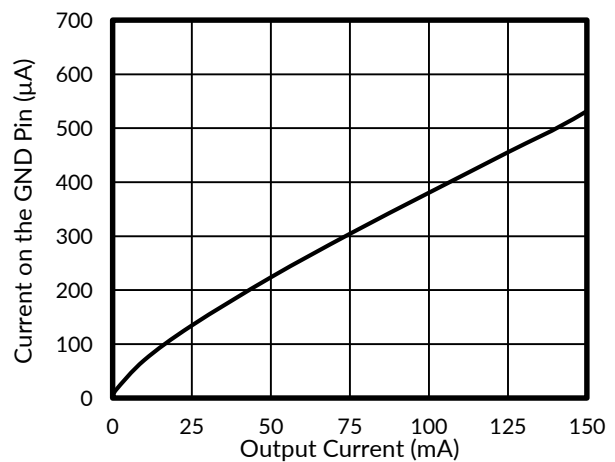

Figure 6. Ground Pin Current vs Output Current

Typical Characteristics

NOTE: The graphs and tables provided following this note are a statistical summary based on a limited number of samples and are provided for informational purposes only.

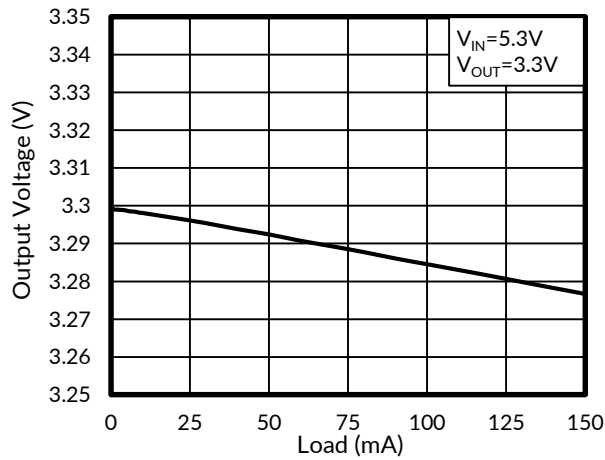

Figure 7. Load Regulation

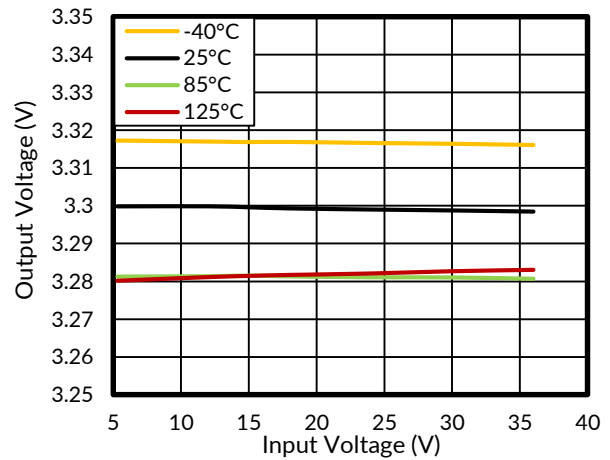

Figure 8. Line Regulation

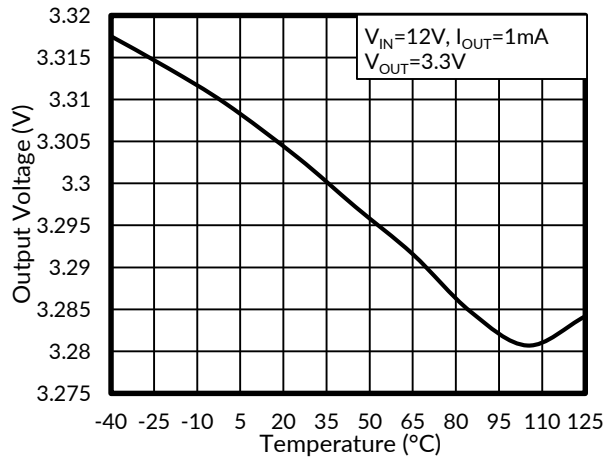

Figure 9. Output Voltage vs Junction Temperature

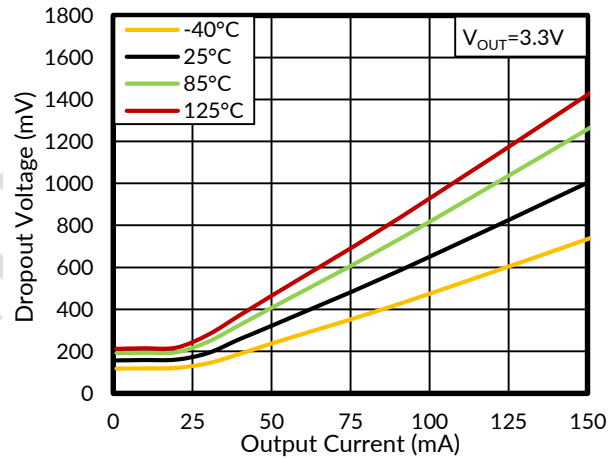

Figure 10. Dropout Voltage vs Output Current

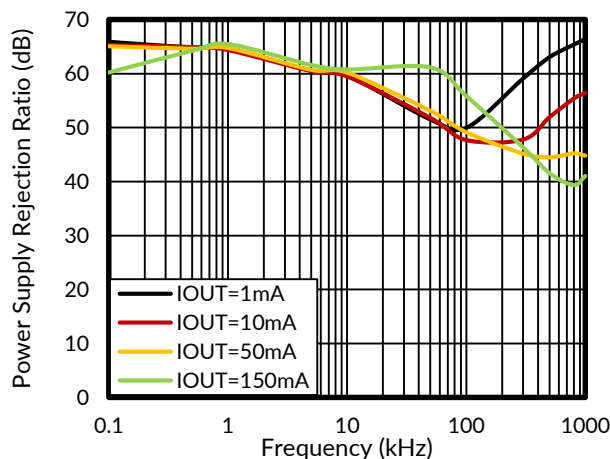

Figure 11. Power Supply Rejection Ratio vs Frequency

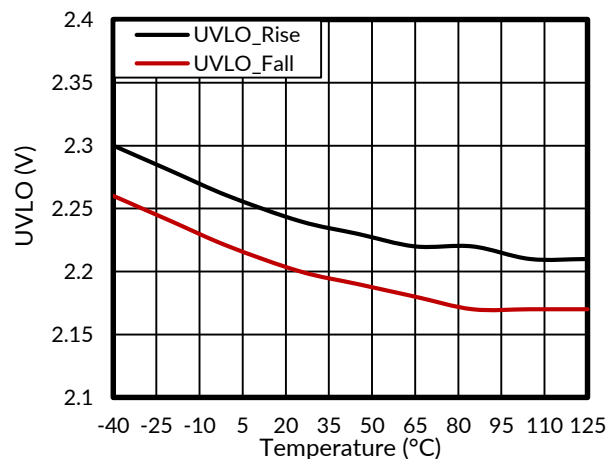

Figure 12. UVLO vs Junction Temperature

Typical Characteristics

NOTE: The graphs and tables provided following this note are a statistical summary based on a limited number of samples and are provided for informational purposes only.

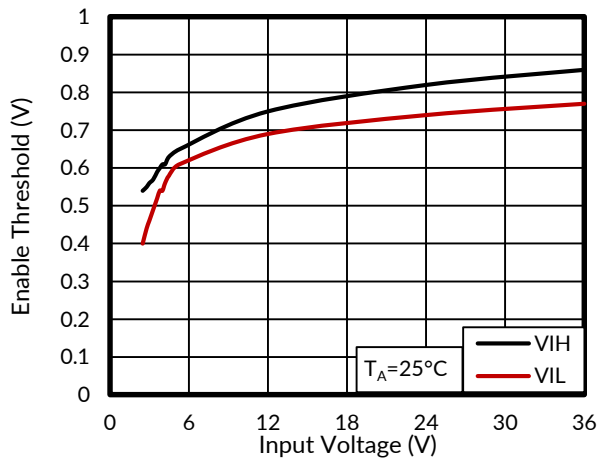

Figure 13. Enable Threshold vs Input Voltage

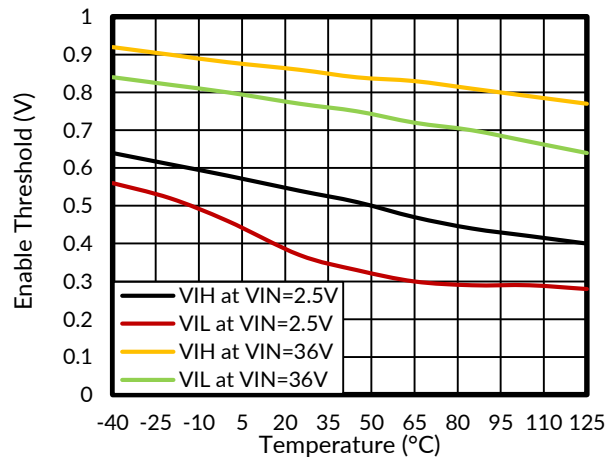

Figure 14. Enable Threshold vs Junction Temperature

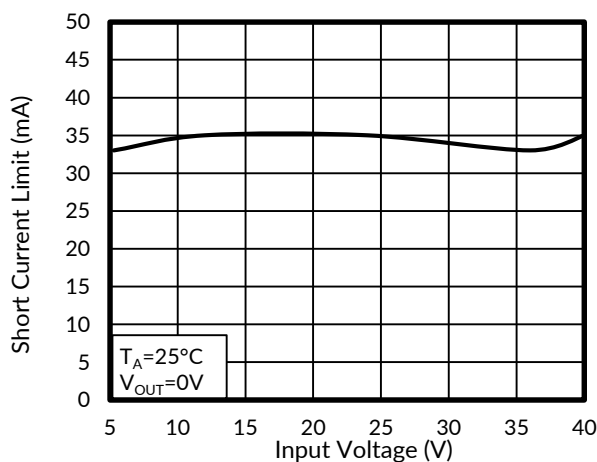

Figure 15. Short Current Limit vs Input Voltage

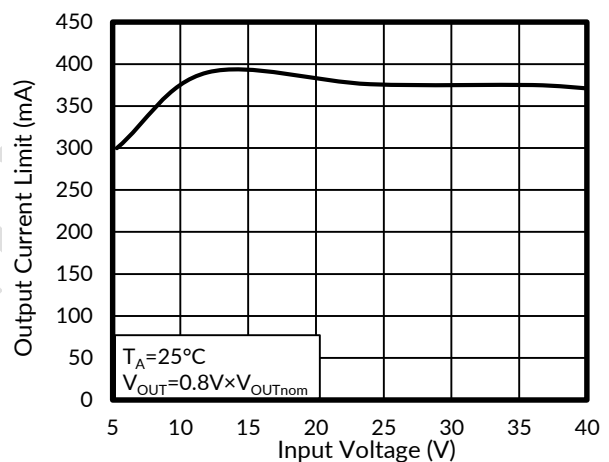

Figure 16. Output Current Limit vs Input Voltage

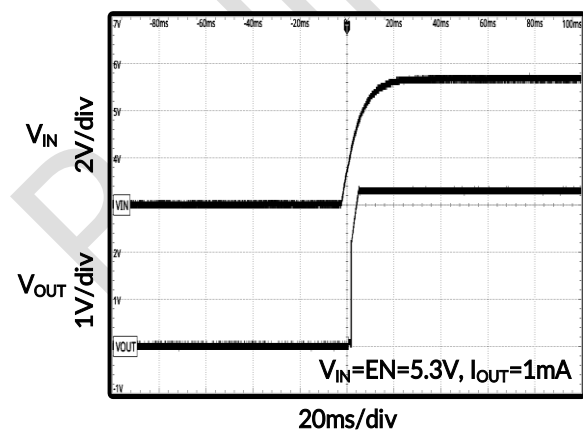

Figure 17. Power On

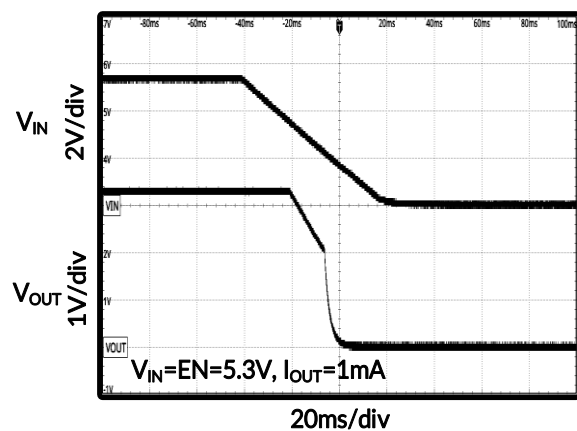

Figure 18. Power Off

Typical Characteristics

NOTE: The graphs and tables provided following this note are a statistical summary based on a limited number of samples and are provided for informational purposes only.

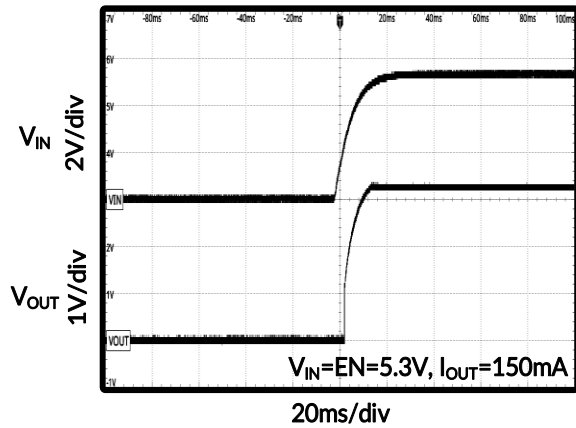

Figure 19. Power On

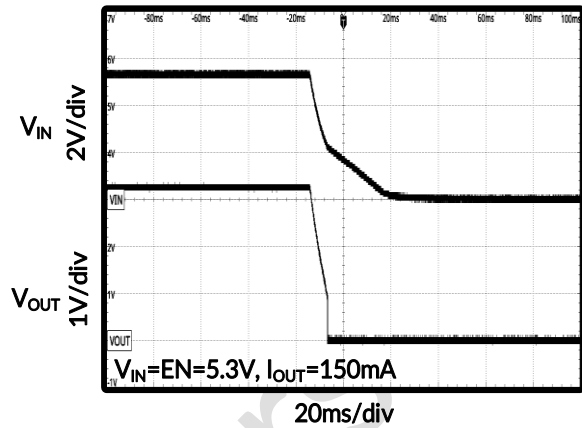

Figure 20. Power Off

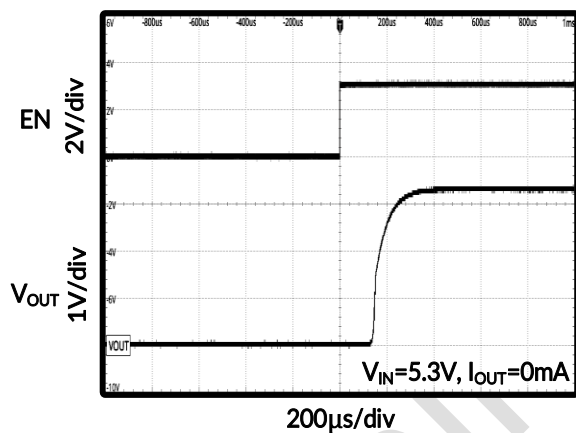

Figure 21. Turn On

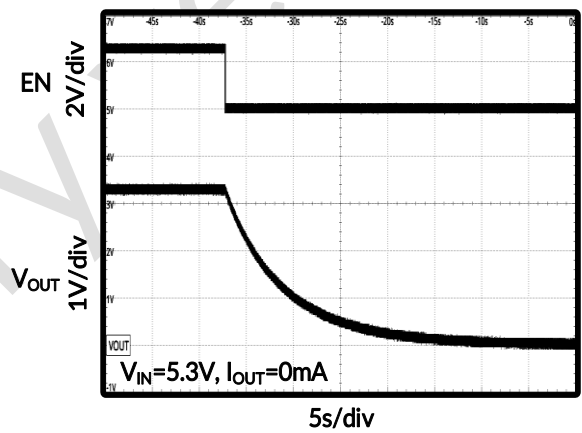

Figure 22. Turn Off

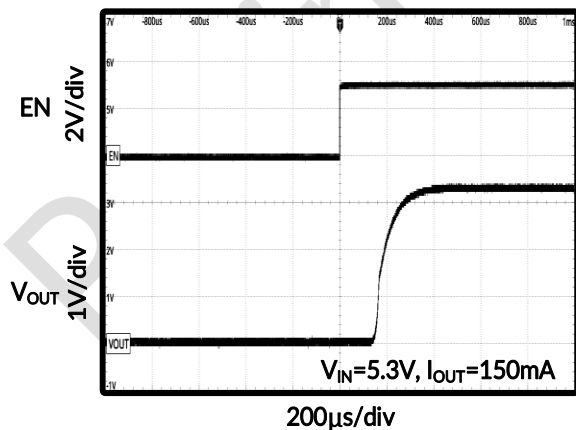

Figure 23. Turn On

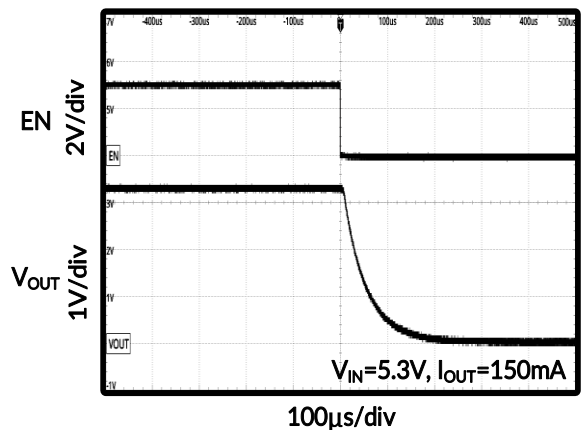

Figure 24. Turn Off

Typical Characteristics

NOTE: The graphs and tables provided following this note are a statistical summary based on a limited number of samples and are provided for informational purposes only.

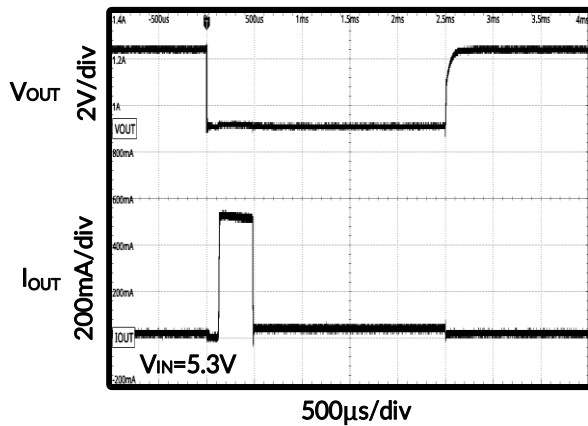

Figure 25. Turn On First, Then Short Circuit

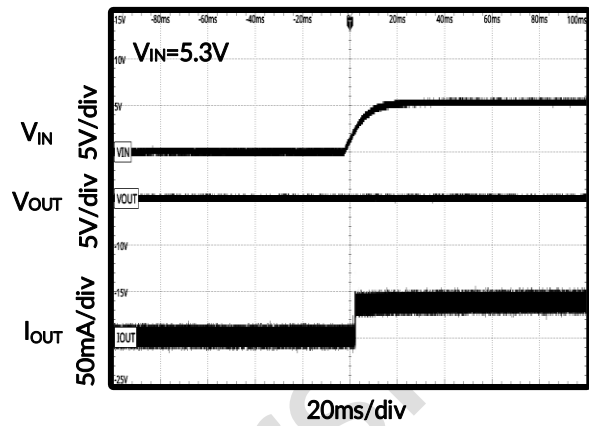

Figure 26. Short Circuit First, Then VIN Power ON

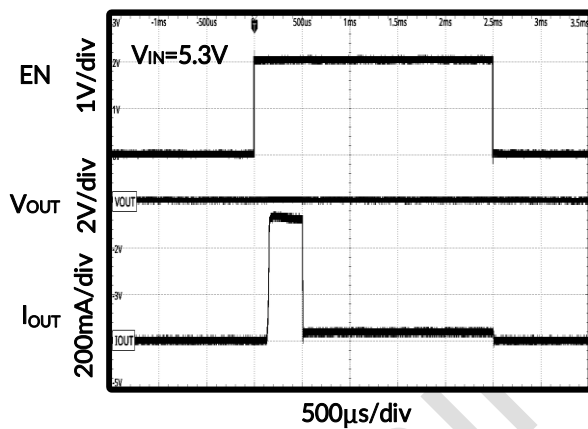

Figure 27. Short Circuit First, Then Enable

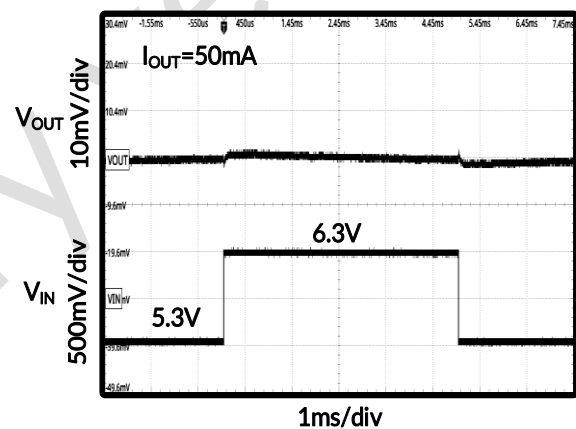

Figure 28. Line Transient Response

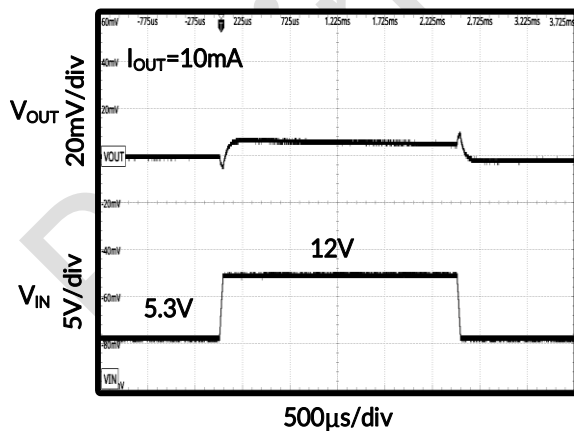

Figure 29. Line Transient Response

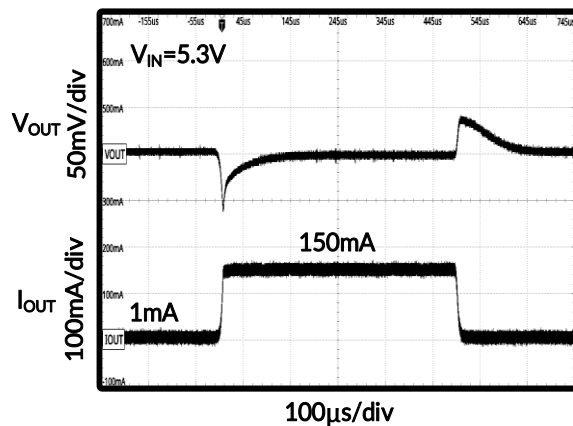

Figure 30. Load Transient Response

Typical Characteristics

NOTE: The graphs and tables provided following this note are a statistical summary based on a limited number of samples and are provided for informational purposes only.

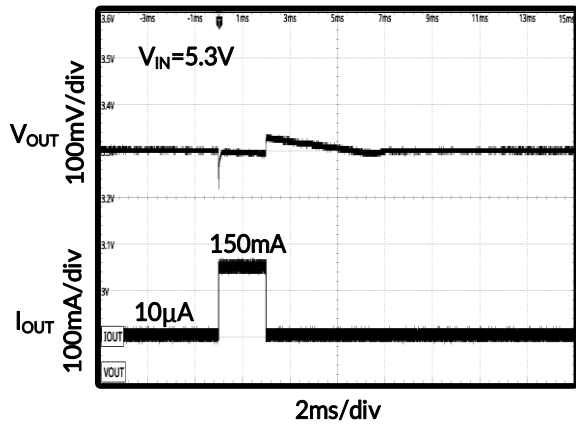

Figure 31. Load Transient Response

Preliminary version

10 DETAILED DESCRIPTION

10.1 Overview

The RS3004 series are a group of positive voltage regulators manufactured by CMOS technologies with low power consumption and low dropout voltage, which provide large output currents even with a small input-output voltage difference. The RS3004 series can deliver 150mA output current and allow input voltages up to 36V. The series are very suitable for the battery-powered equipment, such as RF applications and other systems requiring a quiet voltage source.

10.2 Under Voltage Lockout (UVLO)

The RS3004 family of devices uses an under voltage lockout circuit to keep the output shut off until the internal circuitry is operating properly.

10.3 Shutdown

Enable input. A low voltage ($< V_{IL}$) on this pin turns the regulator off. A high voltage ($> V_{IH}$) on this pin enables the regulator output. The EN pin can be connected to the VIN pin if not used. Do not leave floating.

10.4 Thermal Overload Protection (T_{SD})

Thermal shutdown disables the output when the junction temperature rises to approximately 150°C which allows the device to cool. When the junction temperature cools to approximately 125°C, the output circuitry enables.

Based on power dissipation, thermal resistance, and ambient temperature, the thermal protection circuit may cycle on and off. This thermal cycling limits the dissipation of the regulator and protects it from damage as a result of overheating.

The thermal shutdown circuitry of the RS3004 has been designed to protect against temporary thermal overload conditions. The T_{SD} circuitry was not intended to replace proper heat-sinking. Continuously running the RS3004 device into thermal shutdown may degrade device reliability.

10.5 Disabled

The device is disabled under the following conditions:

- The input voltage is less than the UVLO threshold minus V_{HYS} , or has not yet exceeded the UVLO threshold.
- The enable voltage is less than the enable falling threshold voltage or has not yet exceeded the enable rising threshold.
- The device junction temperature is greater than the thermal shutdown temperature.

10.6 Current-Limit Protection

The RS3004 monitors the current flowing through the output PMOS and limits the maximum current to prevent damage to the load and RS3004 during current overload conditions.

10.7 Short Current-Limit Protection

The short current-limit function reduces the current limit to 35mA (typical) during short circuit conditions.

10.8 Input and Output Capacitor Requirements

Connecting a 1 μ F low-equivalent series resistance (ESR) capacitor across the input supply near the regulator is good analog design practice. This capacitor counteracts reactive input sources and improves transient response and ripple rejection. A higher value capacitor can be necessary if large, fast, rise-time load transients are anticipated or if the device is located several inches from the power source.

The RS3004 family of devices is designed to be stable with standard ceramic output capacitors of values 1 μ F or larger. X5R- and X7R-type capacitors are best because they have minimal variation in value and ESR over temperature.

11 POWER SUPPLY RECOMMENDATIONS

The device is designed to operate from an input voltage supply range between 2.5V and 36V. The input voltage range must provide adequate headroom in order for the device to have a regulated output. This input supply must be well regulated. If the input supply is noisy, additional input capacitors with low ESR can help improve output noise.

12 LAYOUT

For best overall performance, place all circuit components on the same side of the circuit board and as near as practical to the respective LDO pin connections. Place ground return connections to the input and output capacitor, and to the LDO ground pin as close to each other as possible, connected by a wide, component-side, copper surface. The use of vias and long traces to create LDO component connections is strongly discouraged and negatively affects system performance. This grounding and layout scheme minimizes inductive parasitics, and thereby reduces load-current transients, minimizes noise, and increases circuit stability. A ground reference plane is also recommended and is either embedded in the printed circuit board (PCB) itself or located on the bottom side of the PCB opposite the components. This reference plane serves to assure accuracy of the output voltage, shields the LDO from noise, and behaves similar to a thermal plane to spread (or sink) heat from the LDO device when connected to the exposed thermal pad. In most applications, this ground plane is necessary to meet thermal requirements.

To improve ac performance (such as PSRR, output noise, and transient response), designing the board with separate ground planes for V_{IN} and V_{OUT} is recommended, with each ground plane connected only at the GND pin of the device. In addition, the ground connection for the bypass capacitor must connect directly to the GND pin of the device.

Preliminary

13 PACKAGE OUTLINE DIMENSIONS SOT23⁽³⁾

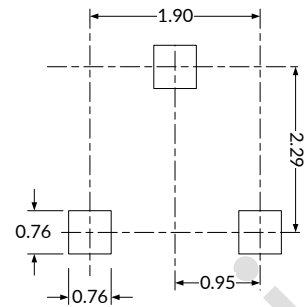
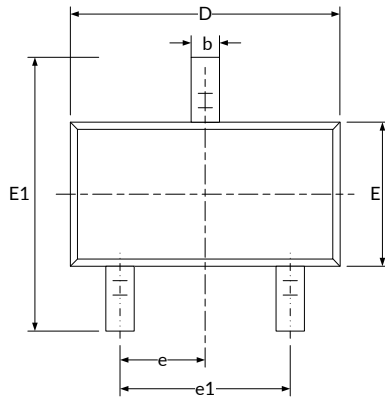
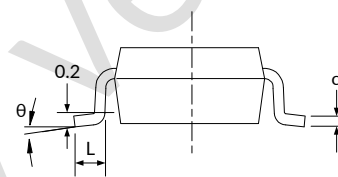
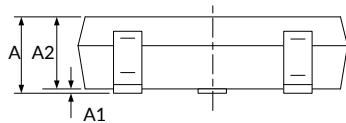
RECOMMENDED LAND PATTERN (Unit: mm)

Symbol	Dimensions In Millimeters		Dimensions In Inches	
	Min	Max	Min	Max
A ⁽¹⁾	0.900	1.150	0.035	0.045
A1	0.000	0.100	0.000	0.004
A2	0.900	1.050	0.035	0.041
b	0.300	0.500	0.012	0.020
c	0.080	0.150	0.003	0.006
D ⁽¹⁾	2.800	3.000	0.110	0.118
E ⁽¹⁾	1.200	1.400	0.047	0.055
E1	2.250	2.550	0.089	0.100
e	0.950(BSC) ⁽²⁾		0.037(BSC) ⁽²⁾	
e1	1.800	2.000	0.071	0.079
L	0.300	0.500	0.012	0.020
θ	0°	8°	0°	8°

NOTE:

1. Plastic or metal protrusions of 0.15mm maximum per side are not included.
2. BSC (Basic Spacing between Centers), "Basic" spacing is nominal.
3. This drawing is subject to change without notice.

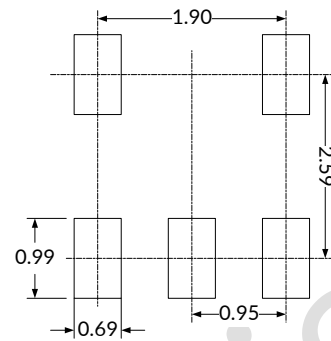
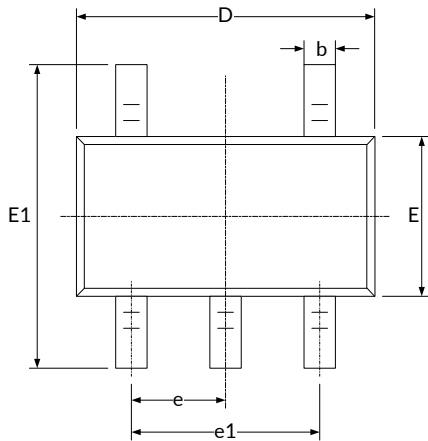
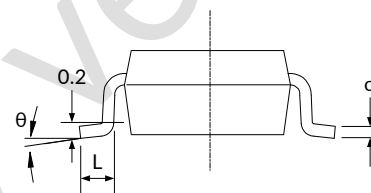
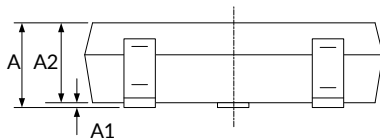
SOT23-5⁽³⁾

RECOMMENDED LAND PATTERN (Unit: mm)

Symbol	Dimensions In Millimeters		Dimensions In Inches	
	Min	Max	Min	Max
A ⁽¹⁾	1.050	1.250	0.041	0.049
A1	0.000	0.100	0.000	0.004
A2	1.050	1.150	0.041	0.045
b	0.300	0.500	0.012	0.020
c	0.100	0.200	0.004	0.008
D ⁽¹⁾	2.820	3.020	0.111	0.119
E ⁽¹⁾	1.500	1.700	0.059	0.067
E1	2.650	2.950	0.104	0.116
e	0.950(BSC) ⁽²⁾		0.037(BSC) ⁽²⁾	
e1	1.800	2.000	0.071	0.079
L	0.300	0.600	0.012	0.024
θ	0°	8°	0°	8°

NOTE:

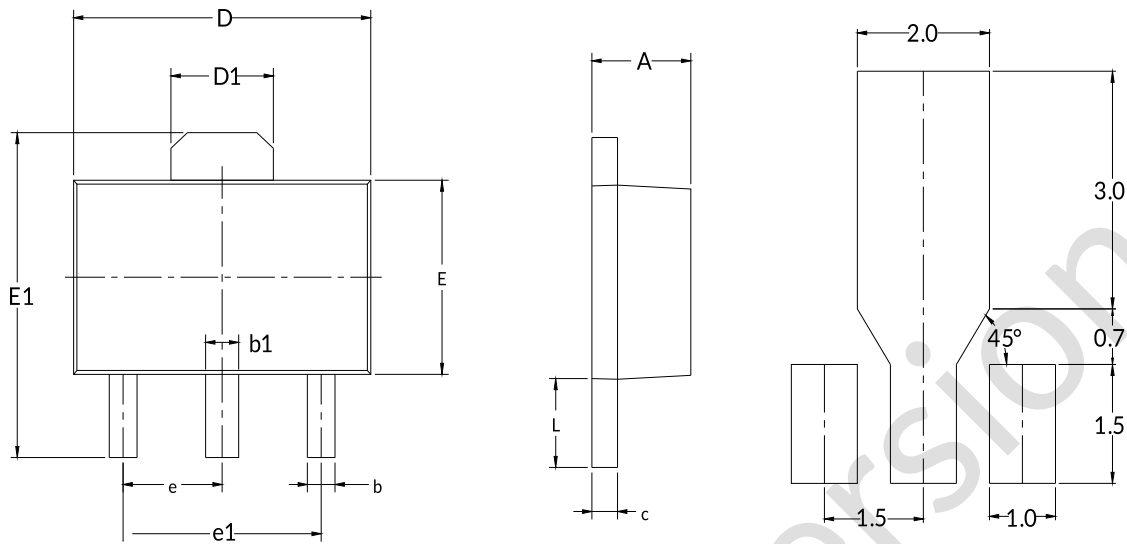
1. Plastic or metal protrusions of 0.15mm maximum per side are not included.
2. BSC (Basic Spacing between Centers), "Basic" spacing is nominal.
3. This drawing is subject to change without notice.

SOT89-3 (4)

RECOMMENDED LAND PATTERN (Unit: mm)

Symbol	Dimensions In Millimeters		Dimensions In Inches	
	Min	Max	Min	Max
A ⁽¹⁾	1.400	1.600	0.055	0.063
b	0.320	0.520	0.013	0.020
b1	0.400	0.580	0.016	0.023
c	0.350	0.440	0.014	0.017
D ⁽¹⁾	4.400	4.600	0.173	0.181
D1	1.550 REF ⁽²⁾		0.061 REF ⁽²⁾	
E ⁽¹⁾	2.300	2.600	0.091	0.102
E1	3.940	4.250	0.155	0.167
e	1.500 BSC ⁽³⁾		0.060 BSC ⁽³⁾	
e1	3.000 BSC ⁽³⁾		0.118 BSC ⁽³⁾	
L	0.900	1.200	0.035	0.047

NOTE:

1. Plastic or metal protrusions of 0.15mm maximum per side are not included.
2. REF is the abbreviation for Reference.
3. BSC (Basic Spacing between Centers), "Basic" spacing is nominal.
4. This drawing is subject to change without notice.

14 TAPE AND REEL INFORMATION

REEL DIMENSIONS

TAPE DIMENSION

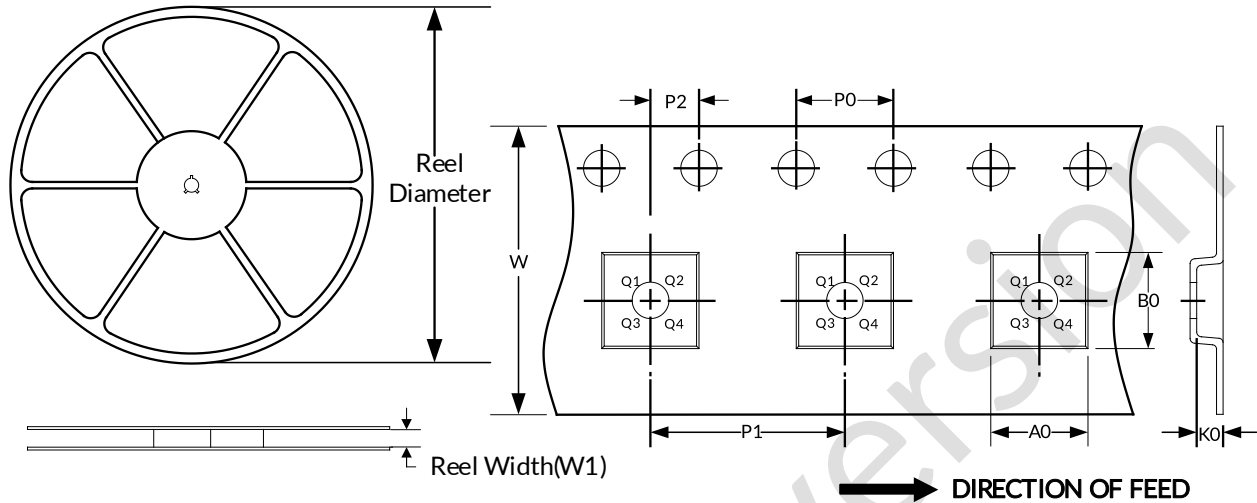

NOTE: The picture is only for reference. Please make the object as the standard.

KEY PARAMETER LIST OF TAPE AND REEL

Package Type	Reel Diameter	Reel Width (mm)	A0 (mm)	B0 (mm)	K0 (mm)	P0 (mm)	P1 (mm)	P2 (mm)	W (mm)	Pin1 Quadrant
SOT23	7"	9.5	3.15	2.77	1.22	4.0	4.0	2.0	8.0	Q3
SOT23-5	7"	9.5	3.20	3.20	1.40	4.0	4.0	2.0	8.0	Q3
SOT89-3	7"	13.2	4.85	4.45	1.85	4.0	8.0	2.0	12.0	Q3

NOTE:

1. All dimensions are nominal.
2. Plastic or metal protrusions of 0.15mm maximum per side are not included.

IMPORTANT NOTICE AND DISCLAIMER

Jiangsu Runic Technology Co., Ltd. will accurately and reliably provide technical and reliability data (including data sheets), design resources (including reference designs), application or other design advice, WEB tools, safety information and other resources, without warranty of any defect, and will not make any express or implied warranty, including but not limited to the warranty of merchantability Implied warranty that it is suitable for a specific purpose or does not infringe the intellectual property rights of any third party.

These resources are intended for skilled developers designing with Runic products You will be solely responsible for: (1) Selecting the appropriate products for your application; (2) Designing, validating and testing your application; (3) Ensuring your application meets applicable standards and any other safety, security or other requirements; (4) Runic and the Runic logo are registered trademarks of Runic Incorporated. All trademarks are the property of their respective owners; (5) For change details, review the revision history included in any revised document. The resources are subject to change without notice. Our company will not be liable for the use of this product and the infringement of patents or third-party intellectual property rights due to its use.

Preliminary version