

4.5Ω Low Voltage SPDT Analog Switch

1 FEATURES

- **Qualified for Automotive Applications**
- **AEC-Q100 Qualified with the Grade 1**
- **High Bandwidth: 340MHz**
- **High Speed:**
 - t_{pd} : 2ns at $V_{CC}=2.3V$ to 5.5V Typically
 - t_{on} : 4ns at $V_{CC}=5V$ Typically
 - t_{off} : 3.5ns at $V_{CC}=5V$ Typically
- **Supply Range: 1.65V to 5.5V**
- **Low ON-State Resistance: 4.5Ω(TYP)**
- **Break-Before-Make Switching**
- **Rail-to-Rail Operation**
- **Extended Industrial Temperature Range: -40°C to 125°C**
- **Micro SIZE PACKAGES: SC70-6**

2 APPLICATIONS

- **Wearable Devices**
- **Battery-Operated Equipment**
- **Signal Gating, Chopping, Modulation or Demodulation (Modem)**
- **Portable Computing**
- **Cell Phones**

3 DESCRIPTIONS

The RS2057A-Q1 is a single-pole double-throw (SPDT) analog switch that is designed to operate from 1.65 V to 5.5 V.

The RS2057A-Q1 device can handle both analog and digital signals. It features high-bandwidth (340MHz) and low on-resistance (4.5Ω TYP).

Applications include signal gating, chopping, modulation or demodulation (modem), and signal multiplexing for analog-to-digital and digital-to-analog conversion systems.

Device Information (1)

PART NUMBER	PACKAGE	BODY SIZE (NOM)
RS2057A-Q1	SC70-6	2.10mm×1.25mm

(1) For all available packages, see the orderable addendum at the end of the data sheet.

4 BLOCK DIAGRAM

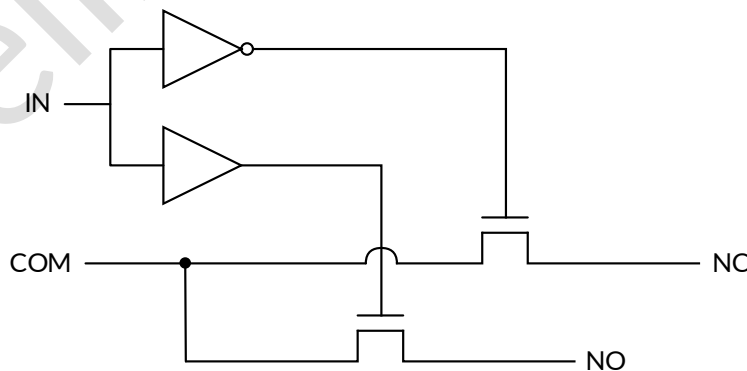

Table of Contents

1 FEATURES	1
2 APPLICATIONS	1
3 DESCRIPTIONS	1
4 BLOCK DIAGRAM	1
5 REVISION HISTORY	3
6 PACKAGE/ORDERING INFORMATION ⁽¹⁾	4
7 PIN CONFIGURATION	5
8 SPECIFICATIONS	6
8.1 Absolute Maximum Ratings	6
8.2 ESD Ratings.....	6
8.3 Recommended Operating Conditions.....	6
8.4 Electrical Characteristics.....	7
8.5 Typical Characteristics	11
9 PARAMETER MEASUREMENT INFORMATION	13
10 APPLICATION AND IMPLEMENTATION	17
10.1 Application Information.....	17
10.2 Typical Application.....	17
11 PACKAGE OUTLINE DIMENSIONS	18
12 TAPE AND REEL INFORMATION	19

5 REVISION HISTORY

Note: Page numbers for previous revisions may differ from page numbers in the current version.

VERSION	Change Date	Change Item
A.0	2025/05/26	Preliminary version completed
A.0.1	2025/10/29	<ol style="list-style-type: none">1. Update ESD Ratings2. Update Electrical Characteristics3. Update PARAMETER MEASUREMENT INFORMATION

Preliminary version

6 PACKAGE/ORDERING INFORMATION (1)

PRODUCT	ORDERING NUMBER	TEMPERATURE RANGE	PACKAGE LEAD	Lead finish/Ball material ⁽²⁾	MSL Peak Temp ⁽³⁾	PACKAGE MARKING ⁽⁴⁾	PACKAGE OPTION
RS2057A-Q1	RS2057AXC6-Q1	-40°C ~+125°C	SC70-6 ⁽⁵⁾	NiPdAu	MSL1-260°-Unlimited	2057A	Tape and Reel,3000

NOTE:

- (1) This information is the most current data available for the designated devices. This data is subject to change without notice and revision of this document. For browser-based versions of this data sheet, refer to the right-hand navigation.
- (2) Lead finish/Ball material. Orderable Devices may have multiple material finish options. Finish options are separated by a vertical ruled line. Lead finish/Ball material values may wrap to two lines if the finish value exceeds the maximum column width.
- (3) RUNIC classify the MSL level with using the common preconditioning setting in our assembly factory conforming to the JEDEC industrial standard J-STD-20F. Please align with RUNIC if your end application is quite critical to the preconditioning setting or if you have special requirement.
- (4) There may be additional marking, which relates to the lot trace code information (data code and vendor code), the logo or the environmental category on the device.
- (5) Equivalent to SOT363.

Preliminary version

7 PIN CONFIGURATION

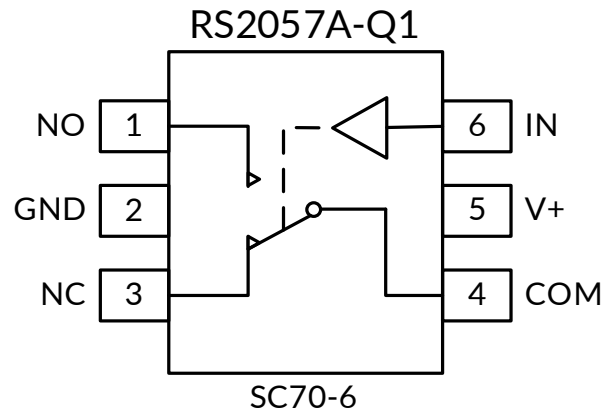

NOTE: NO, NC and COM terminals may be an input or output

PIN DESCRIPTION

NAME	PIN	FUNCTION
	SC70-6	
NO	1	Normally-Open Terminal
GND	2	Ground
NC	3	Normally-Closed Terminal
COM	4	Common Terminal
V+	5	Power Supply
IN	6	Digital Control Pin

FUNCTION TABLE

LOGIC	NO	NC
0	OFF	ON
1	ON	OFF

8 SPECIFICATIONS

8.1 Absolute Maximum Ratings

Over operating free-air temperature range (unless otherwise noted) ⁽¹⁾

SYMBOL	PARAMETER	MIN	MAX	UNIT
V ₊	Supply Voltage	-0.5	6	V
V _{IN}	Input Voltage	-0.5	6	
	Analog, Digital Voltage Range ⁽²⁾	-0.5	(V ₊)+0.5	
	Continuous Current NO, NC, or COM	-50	50	mA
I ₊	Supply current		100	
I _{GND}	Ground current	-100		
θ _{JA}	Package thermal impedance ⁽³⁾	SC70-6		°C/W
T _J	Junction Temperature ⁽⁴⁾		150	°C
T _{stg}	Storage temperature	-65	150	

(1) Stresses above these ratings may cause permanent damage. Exposure to absolute maximum conditions for extended periods may degrade device reliability. These are stress ratings only, and functional operation of the device at these or any other conditions beyond those specified is not implied.

(2) Input terminals are diode-clamped to the power-supply rails. Input signals that can swing more than 0.5V beyond the supply rails should be current-limited to 100mA or less.

(3) The package thermal impedance is calculated in accordance with JESD-51.

(4) The maximum power dissipation is a function of T_{J(MAX)}, R_{θJA}, and T_A. The maximum allowable power dissipation at any ambient temperature is P_D = (T_{J(MAX)} - T_A) / R_{θJA}. All numbers apply for packages soldered directly onto a PCB.

8.2 ESD Ratings

The following ESD information is provided for handling of ESD-sensitive devices in an ESD protected area only.

		VALUE	UNIT
V _(ESD)	Electrostatic discharge	Human-Body Model (HBM), per AEC Q100-002 ⁽¹⁾	±2000
		Charged-Device Model (CDM), per AEC Q100-011	±1000
		Latch-Up (LU), per AEC Q100-004	±100
			mA

(1) AEC Q100-002 indicates that HBM stressing shall be in accordance with the ANSI/ESDA/JEDEC JS-001 specification.



ESD SENSITIVITY CAUTION

ESD damage can range from subtle performance degradation to complete device failure. Precision integrated circuits may be more susceptible to damage because very small parametric changes could cause the device not to meet its published specifications.

8.3 Recommended Operating Conditions

Over operating free-air temperature range (unless otherwise noted)

SYMBOL	PARAMETER	MIN	MAX	UNIT
V ₊	Supply Voltage	1.65	5.5	V
T _A	Operating temperature	-40	125	°C

8.4 Electrical Characteristics

V+ = 5.0 V, T_A = -40°C to 125°C (unless otherwise noted)

PARAMETER	SYMBOL	CONDITIONS	V ₊	T _A	MIN ⁽²⁾	TYP ⁽³⁾	MAX ⁽²⁾	UNIT			
ANALOG SWITCH											
Analog Signal Range	V _{NO} , V _{NC} , V _{COM}			FULL	0		V+	V			
On-Resistance	R _{ON}	V _{NO} or V _{NC} = 0V to V+, I _{COM} = -10mA, Switch ON, See Figure 8	1.65V	+25°C		60	65	Ω			
				FULL			70	Ω			
			1.8V	+25°C		42	50	Ω			
				FULL			60	Ω			
			2.7V	+25°C		11	15	Ω			
				FULL			18	Ω			
			3.3V	+25°C		7.5	10	Ω			
				FULL			13	Ω			
			5V	+25°C		4.5	7.5	Ω			
				FULL			9.5	Ω			
			On-Resistance Match Between Channels	ΔR _{ON}	V _{NO} or V _{NC} = 0V to V+, I _{COM} = -10mA, Switch ON, See Figure 8	1.65V	+25°C		1	1.2	Ω
							FULL			1.5	Ω
1.8V	+25°C					0.8	1	Ω			
	FULL						1.3	Ω			
2.7V	+25°C					0.25	0.35	Ω			
	FULL						0.5	Ω			
3.3V	+25°C					0.15	0.3	Ω			
	FULL						0.4	Ω			
5V	+25°C					0.15	0.3	Ω			
	FULL						0.4	Ω			
On-Resistance Flatness	R _{FLAT(ON)}	V _{NO} or V _{NC} = 0V to V+, I _{COM} = -10mA, Switch ON, See Figure 8				1.65V	+25°C		51	53	Ω
							FULL			55	Ω
			1.8V	+25°C		38	46	Ω			
				FULL			57	Ω			
			2.7V	+25°C		6	7	Ω			
				FULL			8	Ω			
			3.3V	+25°C		3	4	Ω			
				FULL			4.3	Ω			
			5V	+25°C		2	3	Ω			
				FULL			3.3	Ω			
			NC, NO OFF Leakage Current	I _{NC(OFF)} , I _{NO(OFF)}	V _{NO} or V _{NC} = 0.3V, V+/2, V _{COM} = V+/2, 0.3V See Figure 9	1.65V to 5.5V	FULL			1	μA
			NC, NO, COM ON Leakage Current	I _{NC(ON)} , I _{NO(ON)} , I _{COM(ON)}	V _{NO} or V _{NC} = 0.3V, Open, V _{COM} = Open, 0.3V See Figure 10	1.65V to 5.5V	FULL			1	μA

DIGITAL CONTROL INPUTS ⁽¹⁾								
Input High Voltage	V_{INH}		1.65V to 1.95V	FULL	$0.75V_{CC}$			V
			2.3V to 5.5V	FULL	$0.7V_{CC}$			V
Input Low Voltage	V_{INL}		1.65V to 1.95V	FULL			$0.25V_{CC}$	V
			2.3V to 5.5V	FULL			$0.3V_{CC}$	V
Input Leakage Current	I_{IN}	$V_{IN} = V_+ \text{ or } 0$	1.65V to 5.5V	FULL			1	μA

(1) All unused digital inputs of the device must be held at VIO or GND to ensure proper device operation.

(2) Limits are 100% production tested at 25°C. Limits over the operating temperature range are ensured through correlations using statistical quality control (SQC) method.

(3) Typical values represent the most likely parametric norm as determined at the time of characterization. Actual typical values may vary over time and will also depend on the application and configuration.

Preliminary version

Electrical Characteristics (continued)
 $V_+ = 5.0\text{ V}$, $T_A = -40^\circ\text{C}$ to 125°C (unless otherwise noted)

PARAMETER	SYMBOL	CONDITIONS	V_+	T_A	MIN	TYP	MAX	UNIT				
DYNAMIC CHARACTERISTICS												
Propagation delay	t_{pd}	t_{PLH} & t_{PHL} , $R_L=500\Omega$, $C_L=50\text{pF}$, See Figure 13	1.65V to 1.95V	FULL		6	9	ns				
			2.3V to 5.5V	FULL		2	2.4					
Turn-On Time	t_{ON}	t_{PZH} & t_{PZL} , $R_L=500\Omega$, $C_L=50\text{pF}$, See Figure 14	1.65V	+25°C		14.5	17	ns				
				FULL	6		28					
			1.8V	+25°C		12.5	13					
				FULL	5		20					
			2.7V	+25°C		7	8					
				FULL	2.5		12					
			3.3V	+25°C		5.5	6.5					
				FULL	2		10					
			5V	+25°C		4	5					
				FULL	1.5		7.5					
			Turn-Off Time	t_{OFF}	t_{PLZ} & t_{PHZ} , $R_L=500\Omega$, $C_L=50\text{pF}$, See Figure 14	1.65V	+25°C			10	13	ns
							FULL		5		21	
1.8V	+25°C					8.5	12					
	FULL	4					18					
2.7V	+25°C					5	7.5					
	FULL	2					12					
3.3V	+25°C					4	6					
	FULL	1.5					9					
5V	+25°C					3.5	4					
	FULL	1.5					6					
Break-Before-Make Time Delay	t_{BBM}	$R_L=50\Omega$, $C_L=50\text{pF}$, See Figure 15				1.65V to 1.95V	FULL		9		ns	
						2.3V to 5.5V	FULL		6			
Off Isolation	O_{ISO}	$R_L = 50\Omega$, Switch OFF, See Figure 17		+25°C		-58		dB				
				+25°C		-75		dB				
Cross talk	X_{TALK}	$R_L = 50\Omega$, Switch OFF, See Figure 18		+25°C		-59		dB				
				+25°C		-76		dB				
-3dB Bandwidth	BW	Switch ON, $R_L = 50\Omega$, See Figure 16	1.65V to 1.95V	+25°C		340		MHz				
			2.3V to 5.5V	+25°C		340		MHz				
Charge injection	Q_C	$C_L = 0.1\text{nF}$, See Figure 19	1.65V	+25°C		3.3		pC				
			1.8V	+25°C		3.5		pC				
			2.7V	+25°C		4		pC				
			3.3V	+25°C		5		pC				
			5V	+25°C		8		pC				

NC, NO OFF Capacitance	$C_{NC(OFF)}$, $C_{NO(OFF)}$	V_{NC} or $V_{NO}=V+/2$ or GND, Switch OFF, See Figure 11		+25°C		9		pF
NC, NO, COM ON Capacitance	$C_{NC(ON)}$, $C_{NO(ON)}$, $C_{COM(ON)}$	V_{NC} or $V_{NO}=V+/2$ or GND, Switch ON, See Figure 11		+25°C		16		pF
POWER REQUIREMENTS								
Power Supply Range	V_+			FULL	1.65		5.5	V
Power Supply Current	I_+	$V_{IN} = \text{GND or } V_+$	5.5V	FULL			1	μA

Preliminary version

8.5 Typical Characteristics

NOTE: The graphs and tables provided following this note are a statistical summary based on a limited number of samples and are provided for informational purposes only.

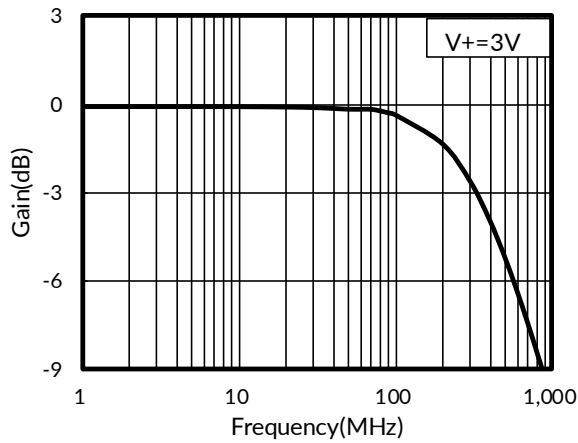

Figure 1. Bandwidth vs Frequency

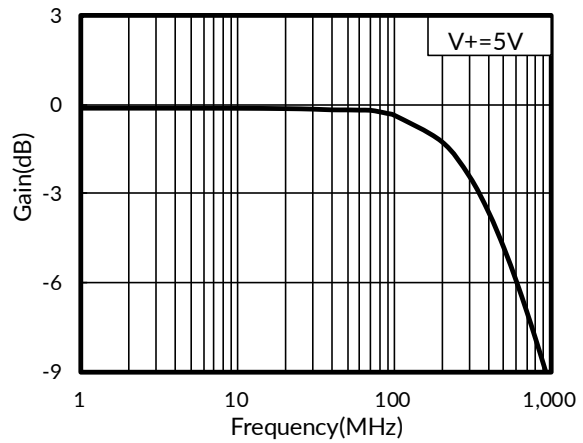

Figure 2. Bandwidth vs Frequency

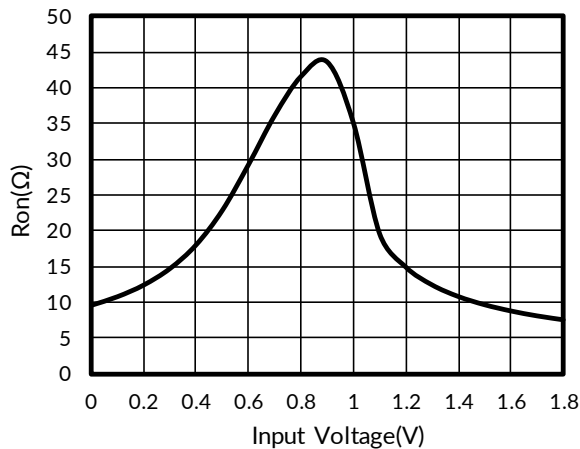

Figure 3. Typical Ron as a Function of Input Voltage (V+= 1.8 V)

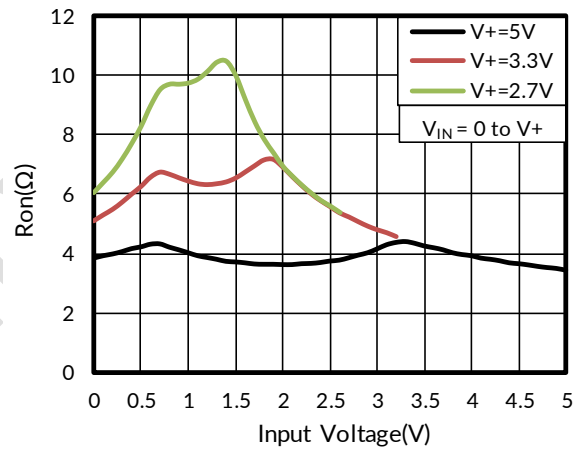

Figure 4. Typical Ron as a Function of Input Voltage

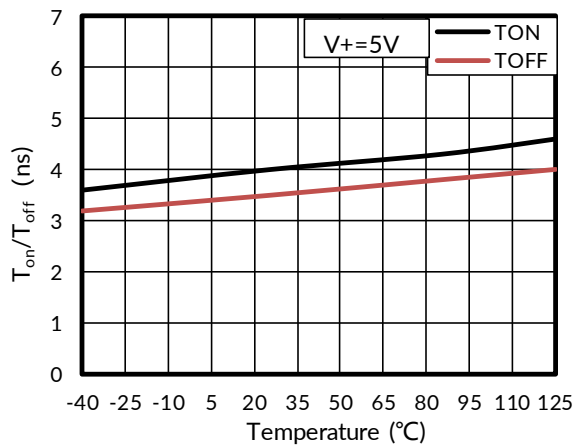

Figure 5. Ton and Toff vs Temperature

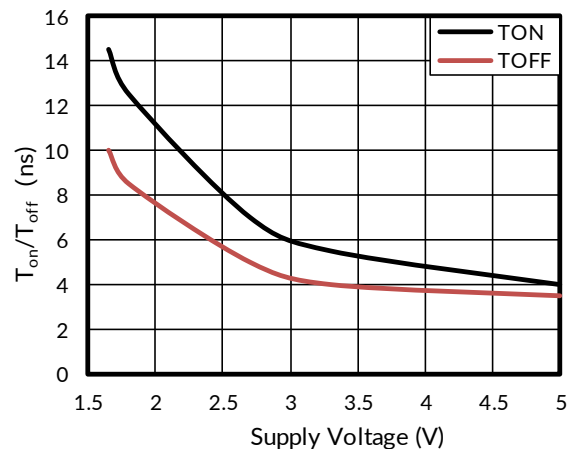

Figure 6. Ton and Toff vs Supply Voltage

Typical Characteristics

NOTE: The graphs and tables provided following this note are a statistical summary based on a limited number of samples and are provided for informational purposes only.



Figure 7. Logic-Level Threshold vs V+

Preliminary version

9 PARAMETER MEASUREMENT INFORMATION

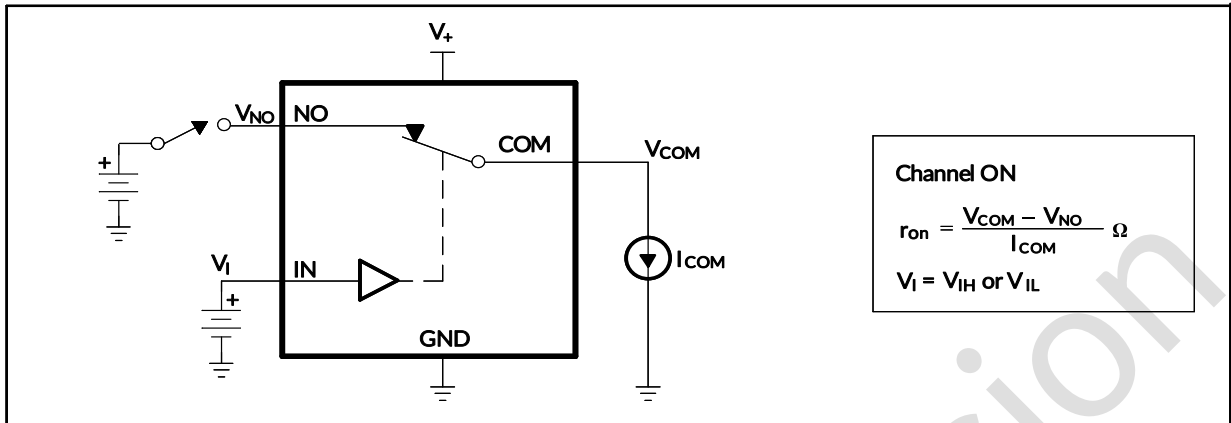

Figure 8. ON-State Resistance (R_{on})

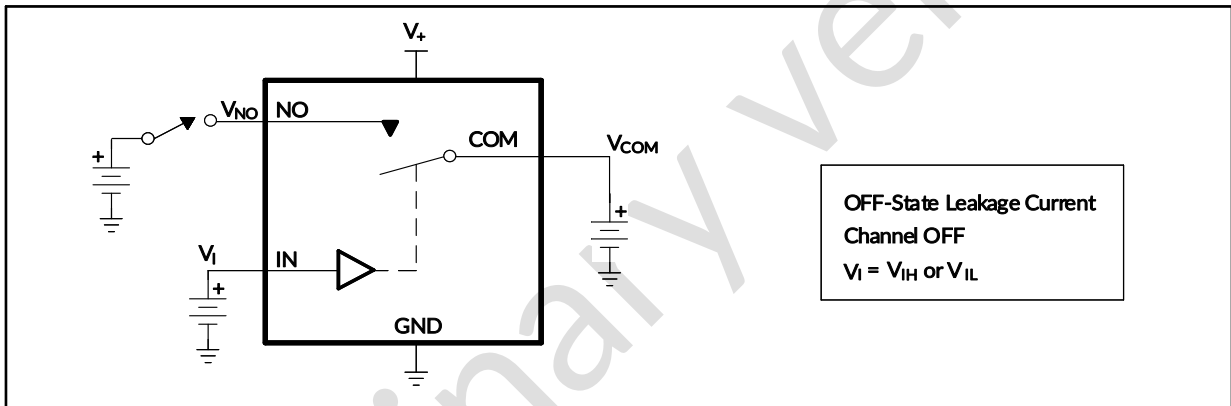

Figure 9. OFF-State Leakage Current ($I_{COM(OFF)}$, $I_{NO(OFF)}$)

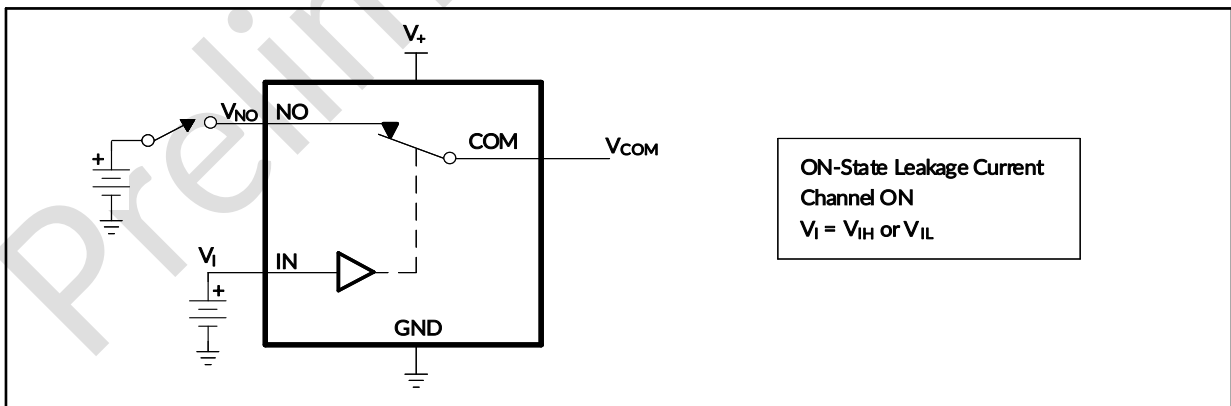
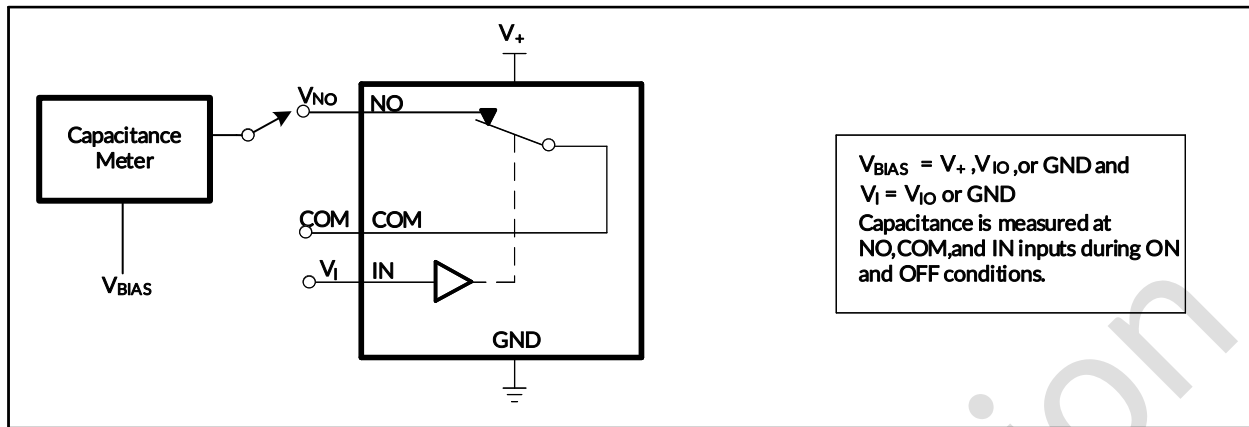
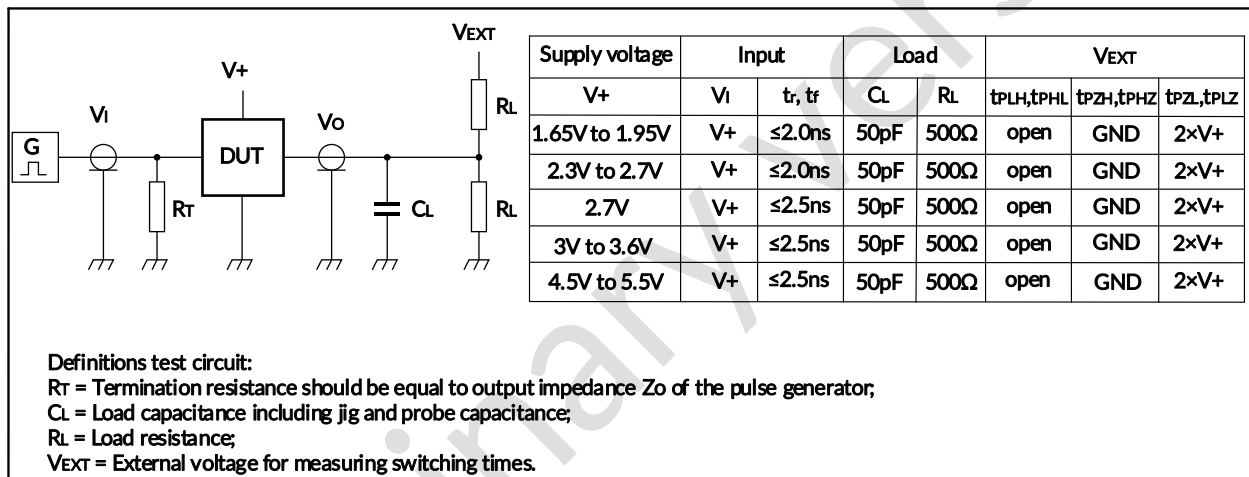
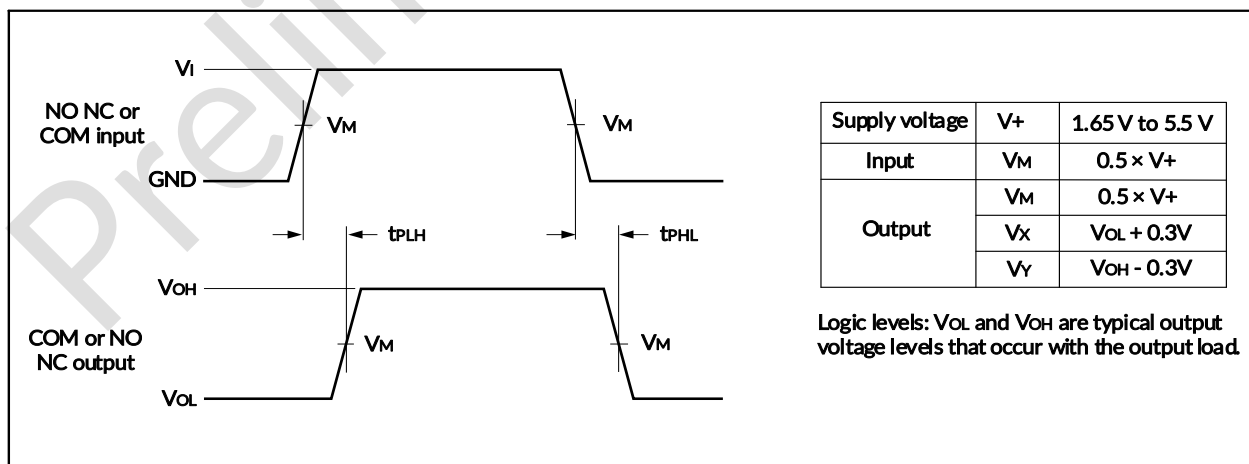
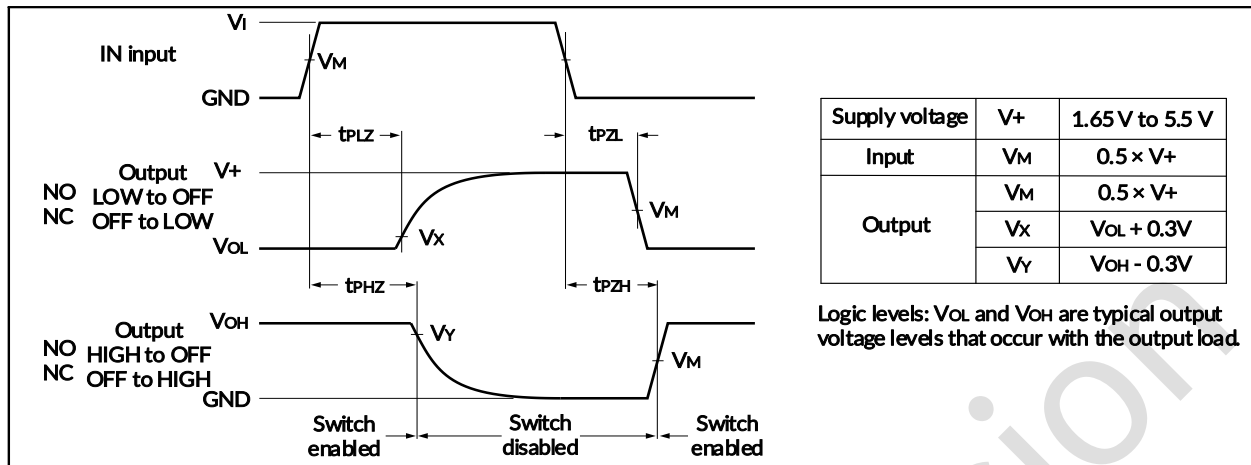
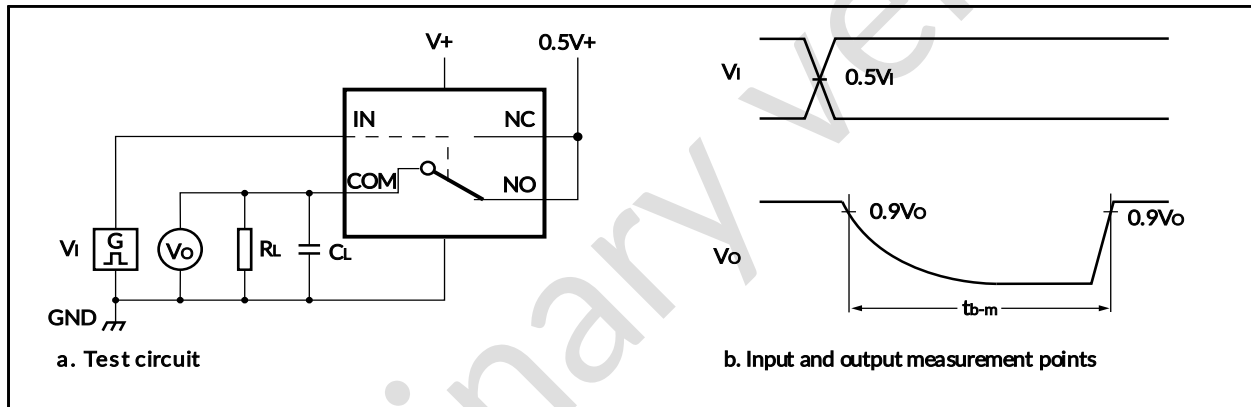
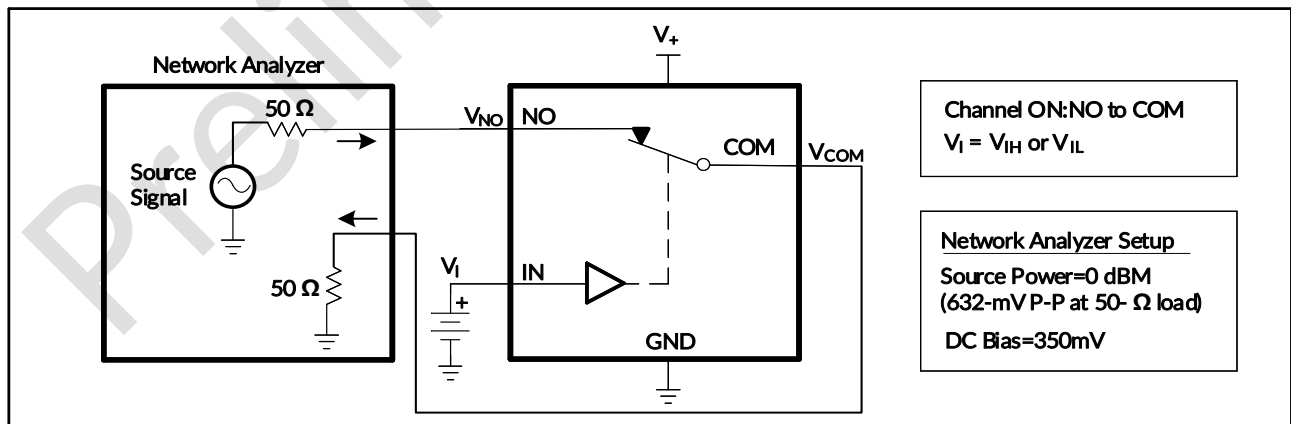
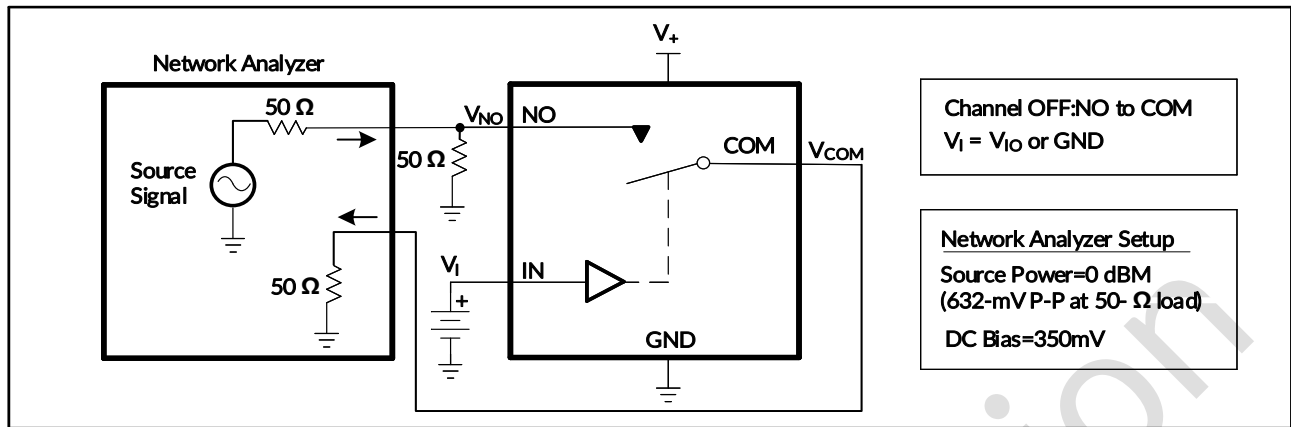
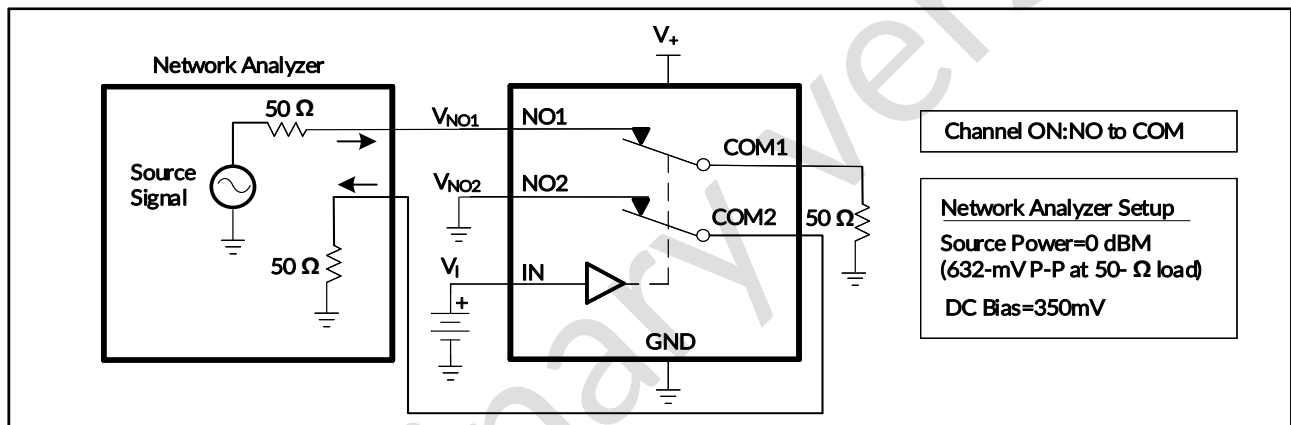
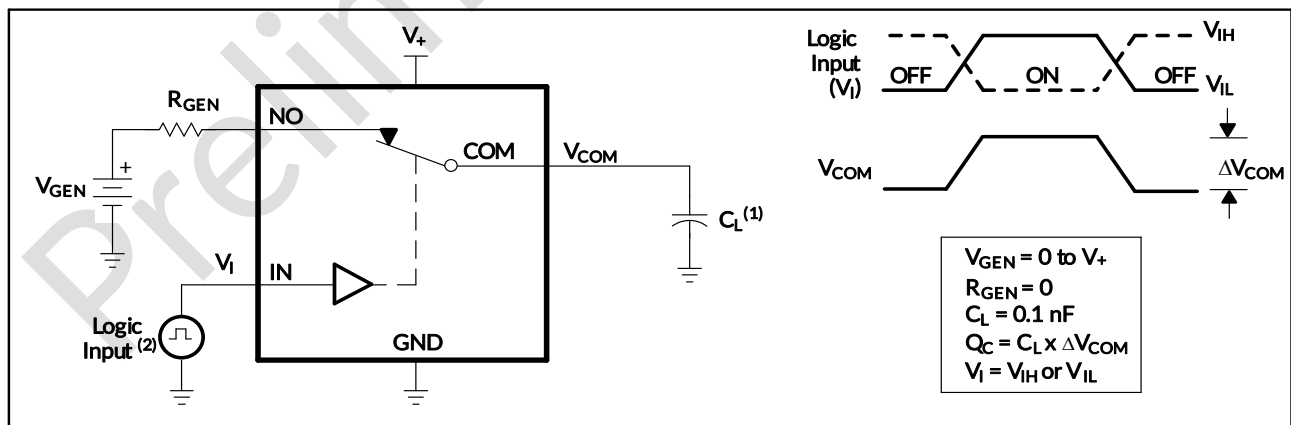

Figure 10. ON-State Leakage Current ($I_{COM(ON)}$, $I_{NO(ON)}$)

Figure 11. Capacitance (C_I , $C_{COM(OFF)}$, $C_{COM(ON)}$, $C_{NO(OFF)}$, $C_{NO(ON)}$)

Figure 12. Test circuit for measuring switching times

Figure 13. Propagation delay (t_{pd})

Figure 14. Turn-On (t_{ON}) and Turn-Off Time (t_{OFF})

Figure 15. Break-Before-Make Time (t_{BBM})

Figure 16. Bandwidth (BW)

Figure 17. OFF Isolation (O_{ISO})

Figure 18. Crosstalk (X_{TALK})

Figure 19. Charge Injection (Q_C)

10 APPLICATION AND IMPLEMENTATION

Information in the following applications sections is not part of the Runic component specification, and Runic does not warrant its accuracy or completeness. Runic's customers are responsible for determining suitability of components for their purposes. Customers should validate and test their design implementation to confirm system functionality.

10.1 Application Information

The RS2057A-Q1 can be used in a variety of customer systems. The RS2057A-Q1 can be used anywhere multiple analog or digital signals must be selected to pass across a single line.

10.2 Typical Application

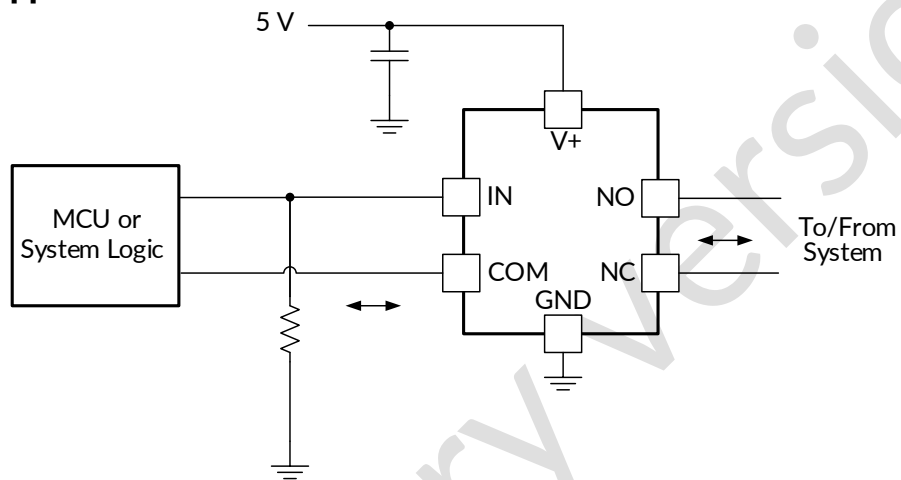
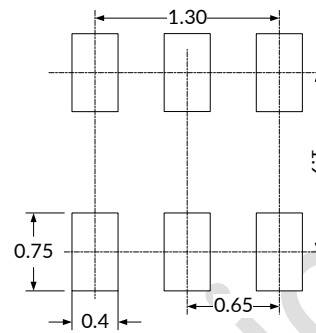
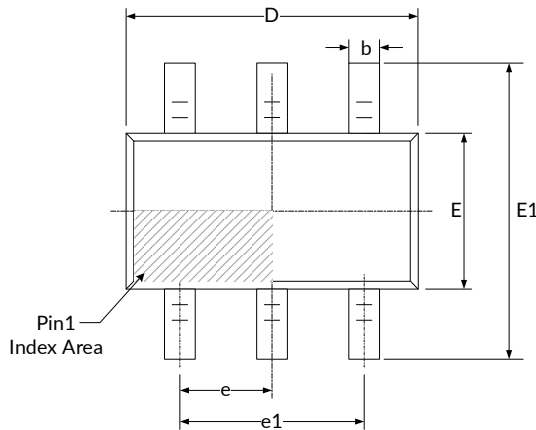
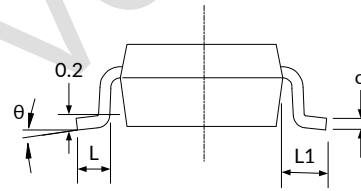
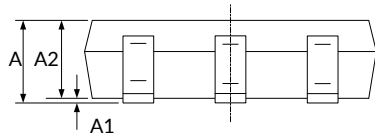

Figure 20. System Schematic for RS2057A-Q1

11 PACKAGE OUTLINE DIMENSIONS

SC70-6 ⁽³⁾

RECOMMENDED LAND PATTERN (Unit: mm)

Symbol	Dimensions In Millimeters		Dimensions In Inches	
	Min	Max	Min	Max
A ⁽¹⁾	0.900	1.100	0.035	0.043
A1	0.000	0.100	0.000	0.004
A2	0.900	1.000	0.035	0.039
b	0.150	0.350	0.006	0.014
c	0.080	0.150	0.003	0.006
D ⁽¹⁾	2.000	2.200	0.079	0.087
E ⁽¹⁾	1.150	1.350	0.045	0.053
E1	2.150	2.450	0.085	0.096
e	0.650 (BSC) ⁽²⁾		0.026 (BSC) ⁽²⁾	
e1	1.300 (BSC) ⁽²⁾		0.051 (BSC) ⁽²⁾	
L	0.260	0.460	0.010	0.018
L1	0.525		0.021	
θ	0°	8°	0°	8°

NOTE:

1. Plastic or metal protrusions of 0.15mm maximum per side are not included.
2. BSC (Basic Spacing between Centers), "Basic" spacing is nominal.
3. This drawing is subject to change without notice.

12 TAPE AND REEL INFORMATION

REEL DIMENSIONS

TAPE DIMENSION

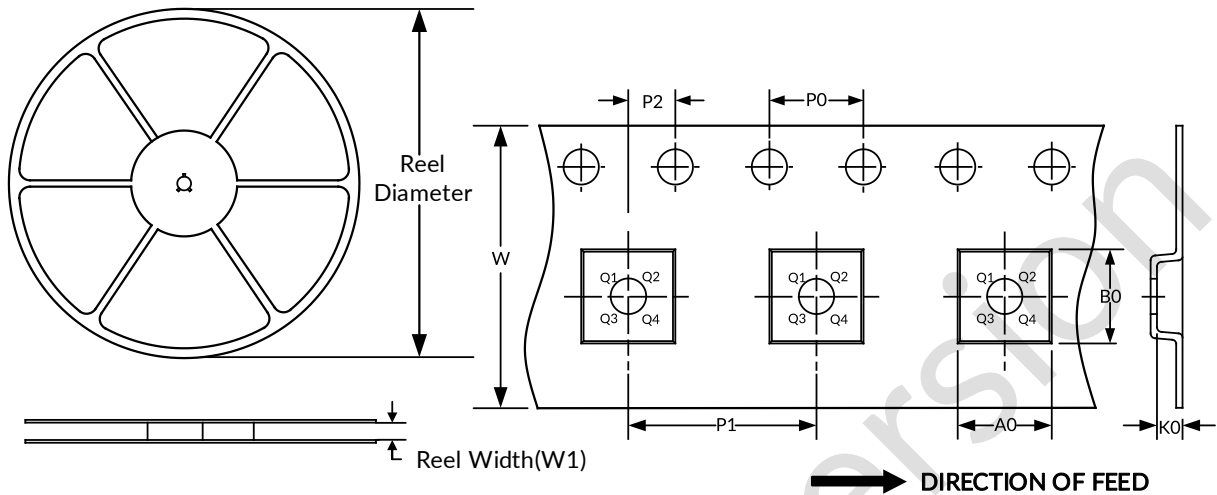

NOTE: The picture is only for reference. Please make the object as the standard.

KEY PARAMETER LIST OF TAPE AND REEL

Package Type	Reel Diameter	Reel Width(mm)	A0 (mm)	B0 (mm)	K0 (mm)	P0 (mm)	P1 (mm)	P2 (mm)	W (mm)	Pin1 Quadrant
SC70-6	7"	9.5	2.40	2.50	1.20	4.0	4.0	2.0	8.0	Q3

NOTE:

1. All dimensions are nominal.
2. Plastic or metal protrusions of 0.15mm maximum per side are not included.

IMPORTANT NOTICE AND DISCLAIMER

Jiangsu Runic Technology Co., Ltd. will accurately and reliably provide technical and reliability data (including data sheets), design resources (including reference designs), application or other design advice, WEB tools, safety information and other resources, without warranty of any defect, and will not make any express or implied warranty, including but not limited to the warranty of merchantability Implied warranty that it is suitable for a specific purpose or does not infringe the intellectual property rights of any third party.

These resources are intended for skilled developers designing with Runic products You will be solely responsible for: (1) Selecting the appropriate products for your application; (2) Designing, validating and testing your application; (3) Ensuring your application meets applicable standards and any other safety, security or other requirements; (4) Runic and the Runic logo are registered trademarks of Runic Incorporated. All trademarks are the property of their respective owners; (5) For change details, review the revision history included in any revised document. The resources are subject to change without notice. Our company will not be liable for the use of this product and the infringement of patents or third-party intellectual property rights due to its use.

Preliminary version