

4PST Depletion Mode Isolation Switch

FEATURES

- 4PST(NC)
- Depletion Mode MOSFETs
- Audio Frequency Range
- Supply Range: +1.6V to +3.0V
- Low ON-State Resistance: 0.5Ω (TYP)
- R_{ON} Flat: 0.01 Ω Typical
- THD+N: 0.002% Typical
- Extended Industrial Temperature Range: -40°C to +85°C
- Available in Green WLCSP1.6X1.2-12 and QFN3X3-16 Package

APPLICATIONS

- MP3 Portable Media Players
- Cell Phones

DESCRIPTION

The RS550 is a high-performance four-pole single throw(4PST) normally closed Depletion-Mode isolation switch. The Depletion Mode technology allows the device to conduct signals when there is no V_{CC} available and to isolate the signals when V_{CC} is present.

The RS550 operates on a wide V_{CC} range for design flexibility. Additionally, select pins allow the internal oscillator frequency to be adjusted between 500 kHz and 750 kHz in 75 kHz steps when V_{CC} is present. This feature is used to shift the electromagnetic interference (EMI) signature to meet customer specifications.

Typical Application Circuit

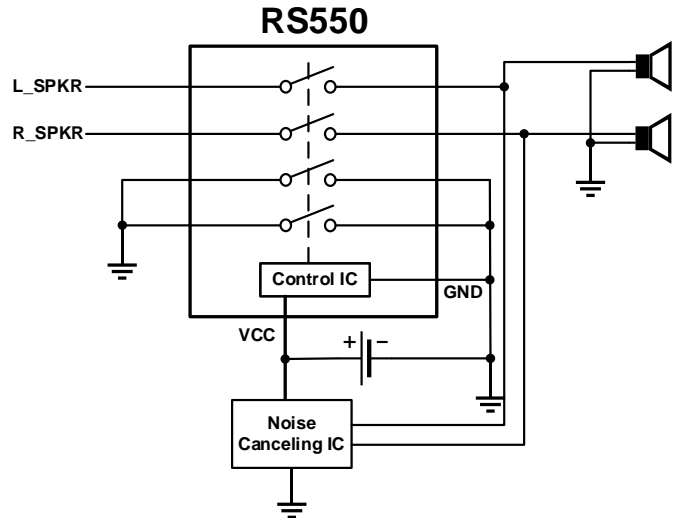

Revision History

Note: Page numbers for previous revisions may differ from page numbers in the current version.

VERSION	Change Date	Change Item
A.1	2019.6.1	Initial version completed
A.2	2019.9.10	Added UQFN2.5x2.5-12 package
B.1	2020.8.1	Added QFN3x3-16 package
B.2	2020.11.12	Deleted UQFN2.5x2.5-12 package
B.2.1	2024/02/23	Modify packaging naming

PIN CONFIGURATIONS

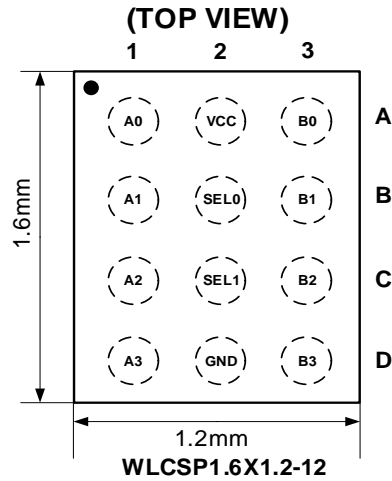

PIN DESCRIPTION

PIN#	NAME	TYPE	DESCRIPTION
A1	A0	I/O	A-Port
B1	A1	I/O	A-Port
C1	A2	I/O	A-Port
D1	A3	I/O	A-Port
A2	VCC	P	Supply Voltage (see Table 1)
B2	SEL0	I	Oscillator Frequency Control (see Table 2). Used to shift the electromagnetic interference (EMI) signature to meet the customer specifications.
C2	SEL1	I	
D2	GND	G	Ground
A3	B0	I/O	B-Port
B3	B1	I/O	B-Port
C3	B2	I/O	B-Port
D3	B3	I/O	B-Port

PIN CONFIGURATIONS

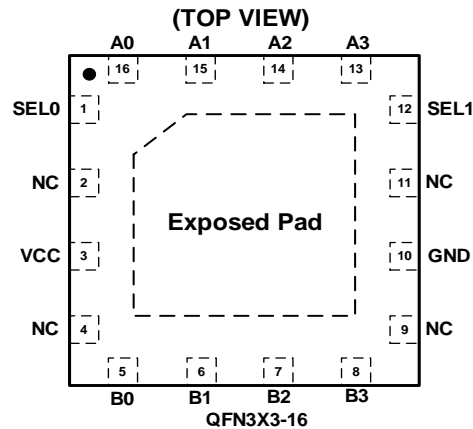

PIN DESCRIPTION

PIN#	NAME	TYPE	DESCRIPTION
1	SEL0	I	Oscillator Frequency Control (see Table 2). Used to shift the electromagnetic interference (EMI) signature to meet the customer specifications.
12	SEL1	I	
2	NC	-	No Connect.
3	VCC	P	Supply Voltage (see Table 1)
4	NC	-	No Connect.
5	B0	I/O	B-Port
6	B1	I/O	B-Port
7	B2	I/O	B-Port
8	B3	I/O	B-Port
9	NC	-	No Connect.
10	GND	G	Ground
11	NC	-	No Connect.
13	A3	I/O	A-Port
14	A2	I/O	A-Port
15	A1	I/O	A-Port
16	A0	I/O	A-Port
--	Exposed Pad	G	Ground or float

Table 1. Truth Table

V _{CC}	Function
0V~0.2V	Conduction; B0~B3=A0~A3
1.6V~3.0V	Disconnect; B0~B3≠A0~A3

Table 2. Oscillator Frequency Step Logic

SEL1	SEL0	Frequency (TYP)
LOW	LOW	500kHz
LOW	HIGH	575kHz
HIGH	LOW	650kHz
HIGH	HIGH	725kHz

SPECIFICATIONS

Absolute Maximum Ratings

Over operating free-air temperature range (unless otherwise noted) ⁽¹⁾

SYMBOL	PARAMETER		MIN	MAX	UNIT
V _{CC}	Supply/Control Voltage,		0	5.5	V
V _{IN}	Input Voltage (Select Pins SEL0, SEL1)		0	V _{CC}	
V _{SW(ON)}	DC Switch I/O Voltage (Switch Conducting)	V _{CC} =0V	-5.0	+5.0	
V _{SW(OFF)} ⁽²⁾	DC Switch I/O Voltage (Switch Isolated)	V _{CC} =Powered	-1.8	+3.0	
I _{IK}	DC Input Diode Current		-50		mA
I _{SW}	Switch I/O Current	V _{CC} =0V		350	
I _{SWPEAK}	Peak Switch Current	Pulsed at 1ms Duration, <10% Duty Cycle		500	
T _A	Absolute Maximum Operating Temperature		-40	+85	°C
T _{stg}	Storage		-65	+150	

(1) Stresses above these ratings may cause permanent damage. Exposure to absolute maximum conditions for extended periods may degrade device reliability. These are stress ratings only, and functional operation of the device at these or any other conditions beyond those specified is not implied.

(2) When a switch is isolated (OFF), V_{SW} value must be < V_{CC}.

ESD Ratings

			VALUE	UNIT
V _(ESD)	Electrostatic discharge	Human-body model (HBM)	±4000	V
		Machine Model (MM)	±200	

Recommended Operating Conditions

Over operating free-air temperature range (unless otherwise noted) ⁽³⁾

SYMBOL	PARAMETER		MIN	MAX	UNIT
V _{CC(ON)}	Supply Voltage with Switch Conducting		0	0.2	V
V _{CC(OFF)}	Supply Voltage with Switch Isolated		1.6	3.0	V
V _{SW(ON)}	DC Switch I/O Voltage (Switch Conducting)	V _{CC} =0V	-2.0	+2.0	V
V _{SW(OFF)}	DC Switch I/O Voltage (Switch Isolated)	V _{CC} =1.6V to 3.0V	-1.6	+1.6	V

(3) The Recommended Operating Condition table defines the conditions for actual device operation. Recommended operating condition are specified to ensure optimal performance to the datasheet specifications.

PACKAGE/ORDERING INFORMATION

PRODUCT	ORDERING NUMBER	TEMPERATURE RANGE	PACKAGE LEAD	PACKAGE MARKING ⁽¹⁾	PACKAGE OPTION
RS550	RS550YUCM12	-40°C ~+85°C	WLCSP1.6X1.2-12	RS550	Tape and Reel,3000
	RS550YTQC16	-40°C ~+85°C	QFN3X3-16	RS550	Tape and Reel,5000

NOTE:

- (1) There may be additional marking, which relates to the lot trace code information(data code and vendor code), the logo or the environmental category on the device.

ELECTRICAL CHARACTERISTICS

Typical values at $T_A = 25^\circ\text{C}$ unless otherwise specified.

PARAMETER	SYMBOL	CONDITIONS	V _{CC} (V)	T _A	MIN	TYP	MAX	UNITS
DC Electrical Characteristics								
Switch-to-GND Leakage Current (Switch Conducting)	I _{ON}	A _n = -1.4 V to 1.4 V, B _n = Float	0	+25°C	0	0.3	2.0	μA
Switch-to-GND Leakage Current (Switch Isolated)	I _{OFF}	A _n = 0.4 V to 1.4 V, B _n = Float	3	+25°C	0	0.5	1.0	μA
Switch On Resistance ⁽⁴⁾	R _{ON}	I _{SW} = ±24 mA, V _{SW} = -1.4V to +1.4V	0	+25°C		0.5		Ω
On Resistance Flatness ⁽⁴⁾	R _{FLAT(ON)}	I _{SW} = ±24 mA, V _{SW} = -1.4V to +1.4V	0	+25°C		0.01		Ω
Quiescent Supply Current	I _{CC}	SEL0 = SEL1 = V _{CC}	3	+25°C	0	40	60	μA
Input Voltage High (Select Pins) ⁽⁵⁾	V _{IH}		3	+25°C	0.8*V _{CC}			V
Input Voltage Low (Select Pins) ⁽⁵⁾	V _{IL}		3	+25°C			0.2*V _{CC}	V
Input Leakage Current (Select Pins)	I _{IN}		3	+25°C	0		±1	μA
AC Electrical Characteristics								
Turn-On Time V _{CC} to Output ^(6,7)	t _{ON}	R _L = 32 Ω, C _L = 10pF, V _{SW} = 1.4V	1.6	+25°C		160		ns
Turn-Off Time V _{CC} to Output ^(6,7)	t _{OFF}	R _L = 32 Ω, C _L = 10pF, V _{SW} = 1.4V	1.6	+25°C		90		μs
Off Isolation ^(6,7)	O _{IRR}	R _L = 32 Ω, f = 20 kHz, V _{SW} = 0.35 V _{RMS}	1.6	+25°C		-80		dB
Crosstalk ^(6,7)	X _{TALK}	R _L = 32 Ω, f = 20 kHz, V _{SW} = 1 V _{RMS}	0	+25°C		-90		dB
-3dB Bandwidth ⁽⁶⁾	BW	R _L = 50 Ω, C _L = 0 pF	0	+25°C		<200		MHZ
Total Harmonic Distortion + Noise ^(6,7)	THD+N	R _L = 32 Ω, f = 20 Hz to 20 kHz, V _{SW} = 1 V _{RMS}	0	+25°C		0.002		%

(4) Guaranteed by test and characterization.

(5) Voltages on select control pins must be <V_{CC}.

(6) SEL0=SEL1=LOW.

(7) Guaranteed by characterization.

PACKAGE OUTLINE DIMENSIONS

WLCSP1.6X1.2-12

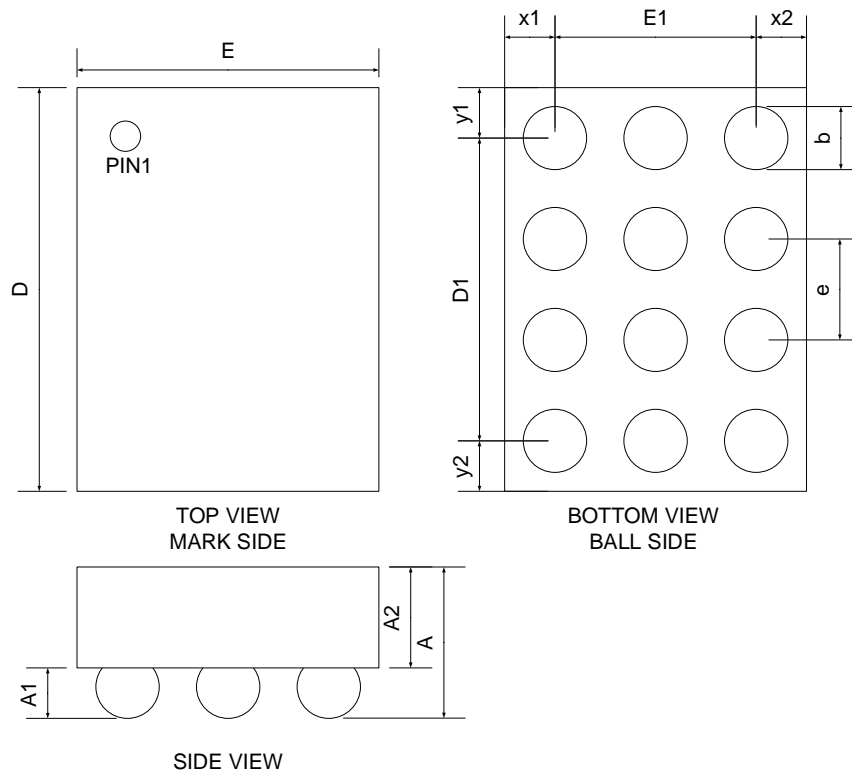

NOTES: ALL WAFER ORIENTATION NOTCH DOWN

SYMBOL	Dimensions In Millimeters			Dimensions In Inches		
	MIN	NOM	MAX	MIN	NOM	MAX
A	0.542	0.582	0.622	0.021	0.023	0.024
A1	0.177	0.202	0.227	0.007	0.008	0.009
A2	0.355	0.380	0.405	0.014	0.015	0.016
D	1.570	1.600	1.630	0.062	0.063	0.064
D1	1.200BSC			0.047BSC		
E	1.170	1.200	1.230	0.046	0.047	0.048
E1	0.800BSC			0.031BSC		
b	0.243	0.268	0.293	0.010	0.011	0.012
e	0.400BSC			0.016BSC		
x1	0.185 REF			0.007REF		
x2	0.185 REF			0.007REF		
y1	0.185 REF			0.007REF		
y2	0.185 REF			0.007REF		

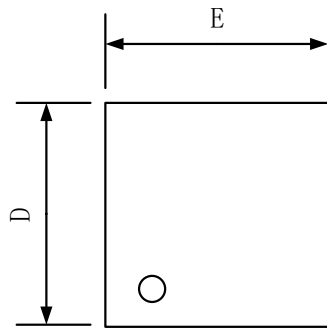
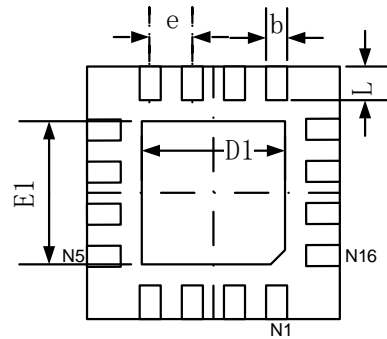
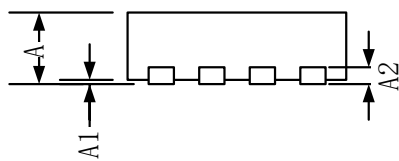
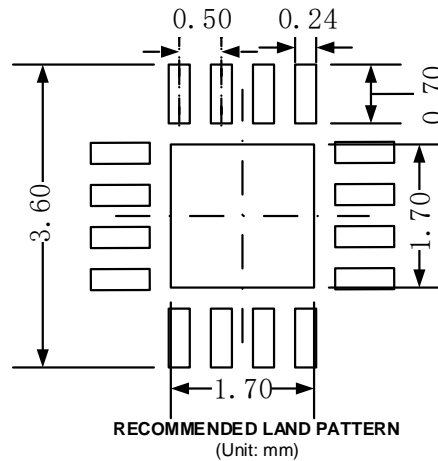
QFN3X3-16

TOP VIEW

BOTTOM VIEW

SIDE VIEW

Symbol	Dimensions In Millimeters		Dimensions In Inches	
	Min	Max	Min	Max
A	0.700	0.800	0.028	0.031
A1	0.000	0.050	0.000	0.002
A2	0.203		0.008	
b	0.180	0.300	0.007	0.012
D	2.900	3.100	0.114	0.122
D1	1.600	1.800	0.063	0.071
E	2.900	3.100	0.114	0.122
E1	1.600	1.800	0.063	0.071
e	0.500 TYP		0.020 TYP	
L	0.300	0.500	0.012	0.020