

4-Bit Dual-Supply Bus Transceiver with Configurable Voltage Translation and 3-State Output

1 FEATURES

- Control Inputs V_{IH}/V_{IL} Levels are Referenced to V_{CCA} Voltage
- Power-Supply Range: V_{CCA} and V_{CCB} : 1.65V to 5.5V
- V_{CC} Isolation: If Either V_{CC} is at GND, Both Ports are in the High-Impedance State
- I_{OFF} : Supports Partial-Power-Down Mode Operation
- Extended Temperature: -40°C to +125°C

2 APPLICATIONS

- Desktop PC
- Personal electronics
- Industrial
- Enterprise

3 DESCRIPTIONS

This 4-bit non-inverting bus transceiver is a bidirectional voltage-level translator and can be used to establish digital switching compatibility between mixed-voltage systems. It uses two separate configurable power-supply rails, Both V_{CCA} and V_{CCB} supporting operating voltages from 1.65 V to 5.5 V, A ports, DIR and \overline{OE} tracks the V_{CCA} supply and B ports tracks the V_{CCB} supply. This allows the support of both lower and higher logic signal levels while providing bidirectional translation capabilities between any of the 1.8V, 2.5V, 3.3V and 5.5V voltage nodes.

The RS4T245 is designed for asynchronous communication between two data buses. The logic levels of the direction-control (DIR) input and the output-enable (\overline{OE}) input activate either the B-port outputs or the A-port outputs or place both output ports into the high-impedance mode. The device transmits data from the A bus to the B bus when the B-port outputs are activated, and from the B bus to the A bus when the A-port outputs are activated. The input circuitry on both A and B ports is always active and must have a logic HIGH or LOW level applied to prevent excess I_{CC} and I_{CCZ} .

This device is fully specified for partial-power-down applications using I_{OFF} . The I_{OFF} circuitry disables the outputs, preventing damaging current backflow through the device when it is powered down.

The V_{CC} isolation feature ensures that if either V_{CC} input is at GND, all outputs are in the high-impedance state.

To ensure the high-impedance state during power up or power down, \overline{OE} should be tied to V_{CC} through a pullup resistor, the minimum value of the resistor is determined by the current-sinking capability of the driver.

The RS4T245 is designed so that the control pins (DIR and \overline{OE}) are supplied by V_{CCA} . It operates over an ambient temperature range of -40°C to +125°C.

Device Information (1)

PART NUMBER	PACKAGE	BODY SIZE (NOM)
RS4T245	TSSOP16(16)	5.00mm×4.40mm
	QFN2.5x3.5-16L	2.50mm×3.50mm

(1) For all available packages, see the orderable addendum at the end of the data sheet.

4 Functional Block Diagram

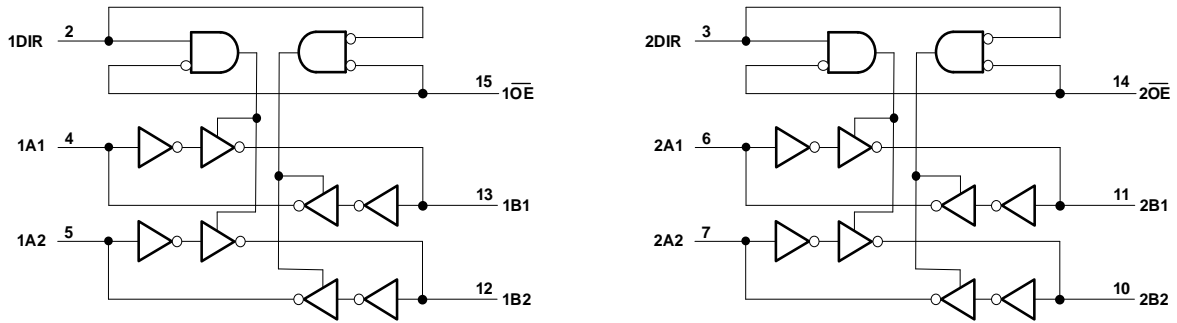

Function Table

CONTROL INPUTS		OUTPUT CIRCUITS		OPERATION
\overline{OE}	DIR	A PORT	B PORT	
L	L	Enabled	Hi-Z	B data to A bus
L	H	Hi-Z	Enabled	A data to B bus
H	X	Hi-Z	Hi-Z	Isolation

Table of Contents

1 FEATURES	1
2 APPLICATIONS	1
3 DESCRIPTIONS	1
4 Functional Block Diagram	2
5 Revision History	4
6 PACKAGE/ORDERING INFORMATION ⁽¹⁾	5
7 PIN CONFIGURATIONS	6
8 SPECIFICATIONS	7
8.1 Absolute Maximum Ratings	7
8.2 ESD Ratings	7
8.3 Recommended Operating Conditions	8
8.4 Electrical Characteristics	9
8.5 Switching Characteristics	10
8.5.1 $V_{CCA}=1.8V\pm 0.15V$	10
8.5.2 $V_{CCA}=2.5V\pm 0.2V$	10
8.5.3 $V_{CCA}=3.3V\pm 0.3V$	11
8.5.4 $V_{CCA}=5V\pm 0.5V$	11
8.6 Operating Characteristics	11
8.7 Typical Characteristics	12
9 Parameter Measurement Information	13
10 Application Information	14
11 PACKAGE OUTLINE DIMENSIONS	15
12 TAPE AND REEL INFORMATION	17

5 Revision History

Note: Page numbers for previous revisions may differ from page numbers in the current version.

VERSION	Change Date	Change Item
A.1	2022/04/07	Initial version completed
A.2	2022/08/31	1.Change ESD Ratings 2.Delete QFN2.6x1.8-16L PACKAGE 3.Update PACKAGE OPTION 4.Modify Application Information

6 PACKAGE/ORDERING INFORMATION ⁽¹⁾

PRODUCT	ORDERING NUMBER	TEMPERATURE RANGE	PACKAGE LEAD	PACKAGE MARKING ⁽²⁾	MSL ⁽³⁾	PACKAGE OPTION
RS4T245	RS4T245XTSS16	-40°C ~+125°C	TSSOP16	RS4T245	MSL3	Tape and Reel,4000
	RS4T245XTQW16	-40°C ~+125°C	QFN2.5x3.5-16L	RS4T245	MSL3	Tape and Reel,5000

NOTE:

- (1) This information is the most current data available for the designated devices. This data is subject to change without notice and revision of this document. For browser-based versions of this data sheet, refer to the right-hand navigation.
- (2) There may be additional marking, which relates to the lot trace code information(data code and vendor code), the logo or the environmental category on the device.
- (3) MSL, The Moisture Sensitivity Level rating according to the JEDEC industry standard classifications.

7 PIN CONFIGURATIONS

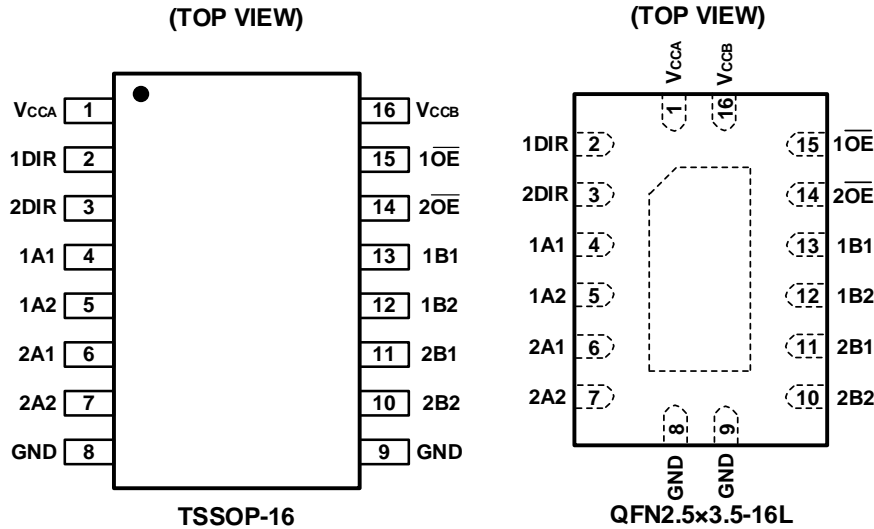

PIN DESCRIPTION

PIN	NAME	TYPE ⁽¹⁾	FUNCTION
TSSOP-16/ QFN2.5x3.5-16L			
1	V _{CCA}	P	A-port supply voltage. $1.65V \leq V_{CCA} \leq 5.5V$
2	1DIR	I	Direction-control input for "1" ports.
3	2DIR	I	Direction-control input for "2" ports.
4	1A1	I/O	Input/output 1A1. Reference to V _{CCA} .
5	1A2	I/O	Input/output 1A2. Reference to V _{CCA} .
6	2A1	I/O	Input/output 2A1. Reference to V _{CCA} .
7	2A2	I/O	Input/output 2A2. Reference to V _{CCA} .
8	GND	G	Ground.
9	GND	G	Ground.
10	2B2	I/O	Input/output 2B2. Reference to V _{CCB} .
11	2B1	I/O	Input/output 2B1. Reference to V _{CCB} .
12	1B2	I/O	Input/output 1B2. Reference to V _{CCB} .
13	1B1	I/O	Input/output 1B1. Reference to V _{CCB} .
14	2OE	I	Output Enable (Active Low). Pull 2OE high to place all "2" outputs in 3-state mode. Referenced to V _{CCA} .
15	1OE	I	Output Enable (Active Low). Pull 1OE high to place all "1" outputs in 3-state mode. Referenced to V _{CCA} .
16	V _{CCB}	P	B-port supply voltage. $1.65V \leq V_{CCB} \leq 5.5V$

(1) I=input, O=output, I/O=input and output, P=power

8 SPECIFICATIONS

8.1 Absolute Maximum Ratings

Over operating free-air temperature range (unless otherwise noted) ⁽¹⁾

SYMBOL	PARAMETER	MIN	MAX	UNIT	
V _{CCA}	Supply Voltage Range	-0.5	6.5	V	
V _{CCB}	Supply Voltage Range	-0.5	6.5	V	
V _I ⁽²⁾	Input Voltage Range	A port	-0.5	6.5	V
		B port	-0.5	6.5	V
		Control inputs	-0.5	6.5	V
V _O ⁽²⁾	Voltage range applied to any output in the high-impedance or power-off state	A port	-0.5	6.5	V
		B port	-0.5	6.5	V
V _O ⁽²⁾⁽³⁾	Voltage range applied to any output in the high or low state	A port	-0.5	V _{CCA} +0.5	V
		B port	-0.5	V _{CCB} +0.5	V
I _{IK}	Input clamp current			-50	mA
I _{OK}	Output clamp current			-50	mA
I _O	Continuous output current			±50	mA
	Continuous current through V _{CCA} , V _{CCB} or GND			±100	mA
T _J	Junction Temperature ⁽⁴⁾	-40	150	°C	
T _{stg}	Storage temperature	-65	+150		

(1) Stresses beyond those listed under *Absolute Maximum Ratings* may cause permanent damage to the device. These are stress ratings only, which do not imply functional operation of the device at these or any other conditions beyond those indicated under *Recommended Operating Conditions*. Exposure to absolute-maximum-rated conditions for extended periods may affect device reliability.

(2) The input and output negative-voltage ratings may be exceeded if the input and output current ratings are observed.

(3) The value of V_{CCA} and V_{CCB} are provided in the recommended operating conditions table.

(4) The maximum power dissipation is a function of T_{J(MAX)}, R_{θJA}, and T_A. The maximum allowable power dissipation at any ambient temperature is P_D = (T_{J(MAX)} - T_A) / R_{θJA}. All numbers apply for packages soldered directly onto a PCB.

8.2 ESD Ratings

The following ESD information is provided for handling of ESD-sensitive devices in an ESD protected area only.

			VALUE	UNIT
V _(ESD)	Electrostatic discharge	Human-body model (HBM), per ANSI/ESDA/JEDEC JS-001 ⁽¹⁾	±2000	V
		Charged-device model (CDM), per ANSI/ESDA/JEDEC JS-002 ⁽²⁾	±1500	V
		Machine Model (MM)	±200	V

(1) JEDEC document JEP155 states that 500 V HBM allows safe manufacturing with a standard ESD control process.

(2) JEDEC document JEP157 states that 250 V CDM allows safe manufacturing with a standard ESD control process.



ESD SENSITIVITY CAUTION

ESD damage can range from subtle performance degradation to complete device failure. Precision integrated circuits may be more susceptible to damage because very small parametric changes could cause the device not to meet its published specifications.

8.3 Recommended Operating Conditions

V_{CCI} is the supply voltage associated with the input port. V_{CCO} is the supply voltage associated with the output port.

PARAMETER		V _{CCI} ⁽¹⁾	V _{CCO} ⁽²⁾	MIN	TYP	MAX	UNIT
Supply voltage ⁽¹⁾	V _{CCA}			1.65		5.5	V
	V _{CCB}			1.65		5.5	
High-level input Voltage (V _{IH})	Data inputs ⁽⁵⁾	1.65V to 1.95V		V _{CCI} x0.65			V
		2.3V to 2.7V		1.7			
		3V to 3.6V		2			
		4.5V to 5.5V		V _{CCI} x0.7			
Low-level input Voltage (V _{IL})	Data inputs ⁽⁵⁾	1.65V to 1.95V				V _{CCI} x0.35	V
		2.3V to 2.7V				0.7	
		3V to 3.6V				0.8	
		4.5V to 5.5V				V _{CCI} x0.3	
High-level input Voltage (V _{IH})	Control inputs (referenced to V _{CCA}) ⁽⁶⁾	1.65V to 1.95V		V _{CCA} x0.65			V
		2.3V to 2.7V		1.7			
		3V to 3.6V		2			
		4.5V to 5.5V		V _{CCA} x0.7			
Low-level input Voltage (V _{IL})	Control inputs (referenced to V _{CCA}) ⁽⁶⁾	1.65V to 1.95V				V _{CCA} x0.35	V
		2.3V to 2.7V				0.7	
		3V to 3.6V				0.8	
		4.5V to 5.5V				V _{CCA} x0.3	
Input voltage (V _I)	Control inputs ⁽⁴⁾			0		5.5	V
Input/output voltage (V _{I/O})	Active state			0		V _{CCO}	V
	3-state			0		5.5	V
High-level output current (I _{OH})		1.65V to 1.95V				-4	mA
		2.3V to 2.7V				-8	
		3V to 3.6V				-24	
		4.5V to 5.5V				-32	
Low-level output current (I _{OL})		1.65V to 1.95V				4	mA
		2.3V to 2.7V				8	
		3V to 3.6V				24	
		4.5V to 5.5V				32	
Input transition rise or fall rate(Δt/Δv)	Data inputs ⁽³⁾	1.65V to 1.95V				20	ns/V
		2.3V to 2.7V				20	
		3V to 3.6V				10	
		4.5V to 5.5V				5	
T _A Operating free-air temperature				-40		125	°C

(1) V_{CCI} is the V_{CC} associated with the data input port.

(2) V_{CCO} is the V_{CC} associated with the output port.

(3) All unused or driven (floating) data inputs (I/Os) of the device must be held at logic HIGH or LOW (preferably V_{CCI} or GND) to ensure proper device operation and minimize power.

(4) All unused control inputs must be held at V_{CCA} or GND to ensure proper device operation and minimize power consumption.

(5) For V_{CCI} values not specified in the data sheet, V_{IH} min = V_{CCI} x 0.7 V, V_{IL} max = V_{CCI} x 0.3 V.

(6) For V_{CCA} values not specified in the data sheet, V_{IH} min = V_{CCA} x 0.7 V, V_{IL} max = V_{CCA} x 0.3 V.

8.4 Electrical Characteristics

over recommended operating free-air temperature range (unless otherwise noted) ^{(1) (2)}

PARAMETER		CONDITIONS	V _{CCA}	V _{CCB}	TEMP	MIN ⁽³⁾	TYP ⁽⁴⁾	MAX ⁽³⁾	UNIT	
V _{OH}		I _{OH} = -100 μA V _I =V _{IH}	1.65V to 4.5V	1.65V to 4.5V	Full	V _{CCO} - 0.1			V	
		I _{OH} = -4mA V _I =V _{IH}	1.65V	1.65V		1.2				
		I _{OH} = -8mA V _I =V _{IH}	2.3V	2.3V		1.9				
		I _{OH} = -24mA V _I =V _{IH}	3V	3V		2.4				
		I _{OH} = -32mA V _I =V _{IH}	4.5V	4.5V		3.8				
V _{OL}		I _{OL} = 100 μA V _I =V _{IL}	1.65V to 4.5V	1.65V to 4.5V					0.1	V
		I _{OL} = 4mA V _I =V _{IL}	1.65V	1.65V					0.45	
		I _{OL} = 8mA V _I =V _{IL}	2.3V	2.3V					0.3	
		I _{OL} = 24mA V _I =V _{IL}	3V	3V					0.55	
		I _{OL} = 32mA V _I =V _{IL}	4.5V	4.5V					0.55	
I _I	DIR	V _I = V _{CCA} or GND	1.65V to 5.5V	1.65V to 5.5V	+25°C			±1	μA	
					Full			±2		
I _{off}	A or B Port	V _I or V _O = 0 to 5.5V	0V	0V to 5.5V	+25°C			±1	μA	
			0V to 5.5V	0V	Full			±2		
I _{OZ} ⁽⁵⁾	A or B Port	V _O =V _{CCO} or GND O _E =V _{IH}	1.65V to 5.5V	1.65V to 5.5V	+25°C			±1	μA	
					Full			±2		
I _{CCA}	V _{CCA} supply current	V _I = V _{CCI} or GND ⁽⁶⁾ I _O = 0	1.65V to 5.5V	1.65V to 5.5V	Full			8	μA	
			5V	0V	Full			8		
			0V	5V	Full			-2		
I _{CCB}	V _{CCB} supply current	V _I = V _{CCI} or GND ⁽⁶⁾ I _O = 0	1.65V to 5.5V	1.65V to 5.5V	Full			8	μA	
			5V	0V	Full			-2		
			0V	5V	Full			8		
I _{CCA} + I _{CCB}	Combined supply current	V _I = V _{CCI} or GND I _O = 0	1.65V to 5.5V	1.65V to 5.5V	Full			20	μA	
ΔI _{CCA}	A port	One A port at V _{CCA} - 0.6 V, DIR at V _{CCA} , B port = open	3V to 5.5V	3V to 5.5V	Full			50	μA	
	DIR	DIR at V _{CCA} - 0.6 V, B port = open A port at V _{CCA} or GND			Full			50		
ΔI _{CCB}	B port	One B port at V _{CCB} - 0.6 V, DIR at GND, A port = open	3V to 5.5V	3V to 5.5V	Full			50	μA	
C _I	Control inputs	V _I = V _{CCA} or GND	3.3V	3.3V	+25°C		4		pF	
C _{IO}	A port		3.3V	3.3V	+25°C		8.5		pF	
	B port		3.3V	3.3V	+25°C		8.5			

(1) V_{CCI} is the V_{CC} associated with the input port.

(2) V_{CCO} is the V_{CC} associated with the output port.

(3) Limits are 100% production tested at 25°C. Limits over the operating temperature range are ensured through correlations using statistical quality control (SQC) method.

(4) Typical values represent the most likely parametric norm as determined at the time of characterization. Actual typical values may vary over time and will also depend on the application and configuration.

(5) For I/O ports, the parameter I_{OZ} includes the input leakage current.

(6) Hold all unused data inputs of the device at V_{CCI} or GND to assure proper device operation.

8.5 Switching Characteristics

8.5.1 $V_{CCA}=1.8V\pm 0.15V$

PARAMETER	FROM (INPUT)	TO (OUTPUT)	$V_{CCB}=1.8V \pm 0.15V$		$V_{CCB}=2.5V \pm 0.2V$		$V_{CCB}=3.3V \pm 0.3V$		$V_{CCB}=5V \pm 0.5V$		UNIT
			MIN	MAX	MIN	MAX	MIN	MAX	MIN	MAX	
t_{PLH}	An	Bn	1.7	21.6	1.3	9.1	1.0	7.4	0.8	7.1	ns
t_{PHL}											
t_{PLH}	Bn	An	0.9	23.5	0.8	23.6	0.7	23.3	0.7	23.3	ns
t_{PHL}											
t_{PHZ}	\overline{OE}	An	1.5	29.5	1.5	29.4	1.5	29.3	1.4	29.1	ns
t_{PLZ}											
t_{PHZ}	\overline{OE}	Bn	2.4	32.2	1.9	12.9	1.7	12.0	1.3	10.2	ns
t_{PLZ}											
t_{PZH}	\overline{OE}	An	0.4	23.8	0.4	23.7	0.4	23.7	0.4	23.7	ns
t_{PZL}											
t_{PZH}	\overline{OE}	Bn	1.8	31.9	1.5	16	1.2	12.6	0.9	10.8	ns
t_{PZL}											

8.5.2 $V_{CCA}=2.5V\pm 0.2V$

PARAMETER	FROM (INPUT)	TO (OUTPUT)	$V_{CCB}=1.8V \pm 0.15V$		$V_{CCB}=2.5V \pm 0.2V$		$V_{CCB}=3.3V \pm 0.3V$		$V_{CCB}=5V \pm 0.5V$		UNIT
			MIN	MAX	MIN	MAX	MIN	MAX	MIN	MAX	
t_{PLH}	An	Bn	1.5	21.2	1.2	9.0	0.8	6.7	0.6	4.8	ns
t_{PHL}											
t_{PLH}	Bn	An	1.2	9.2	1.0	9.0	1.0	8.9	0.9	8.8	ns
t_{PHL}											
t_{PHZ}	\overline{OE}	An	1.4	8.8	1.4	8.9	1.4	8.8	1.4	8.8	ns
t_{PLZ}											
t_{PHZ}	\overline{OE}	Bn	2.3	29.6	1.8	11.0	1.7	9.3	0.9	6.9	ns
t_{PLZ}											
t_{PZH}	\overline{OE}	An	1.0	10.8	1.0	10.9	1.0	10.9	1.0	10.9	ns
t_{PZL}											
t_{PZH}	\overline{OE}	Bn	1.7	28.2	1.5	12.9	1.2	9.4	1.0	6.9	ns
t_{PZL}											

Switching Characteristics

8.5.3 $V_{CCA}=3.3V\pm 0.3V$

PARAMETER	FROM (INPUT)	TO (OUTPUT)	$V_{CCB}=1.8V \pm 0.15V$		$V_{CCB}=2.5V \pm 0.2V$		$V_{CCB}=3.3V \pm 0.3V$		$V_{CCB}=5V \pm 0.5V$		UNIT
			MIN	MAX	MIN	MAX	MIN	MAX	MIN	MAX	
t_{PLH}	An	Bn	1.5	21.2	1.1	8.8	0.8	6.3	0.5	5.1	ns
t_{PHL}											
t_{PLH}	Bn	An	0.8	7.2	0.8	6.2	0.7	6.1	0.6	6.0	ns
t_{PHL}											
t_{PHZ}	\overline{OE}	An	1.6	8.2	1.6	8.2	1.6	8.2	1.6	8.2	ns
t_{PLZ}											
t_{PHZ}	\overline{OE}	Bn	2.1	29.0	1.7	10.3	1.5	8.5	0.8	6.3	ns
t_{PLZ}											
t_{PZH}	\overline{OE}	An	0.8	8.1	0.8	8.1	0.8	8.1	0.8	8.1	ns
t_{PZL}											
t_{PZH}	\overline{OE}	Bn	1.8	27.7	1.4	12.4	1.1	8.5	0.9	6.4	ns
t_{PZL}											

8.5.4 $V_{CCA}=5V\pm 0.5V$

PARAMETER	FROM (INPUT)	TO (OUTPUT)	$V_{CCB}=1.8V \pm 0.15V$		$V_{CCB}=2.5V \pm 0.2V$		$V_{CCB}=3.3V \pm 0.3V$		$V_{CCB}=5V \pm 0.5V$		UNIT
			MIN	MAX	MIN	MAX	MIN	MAX	MIN	MAX	
t_{PLH}	An	Bn	1.5	21.3	1.0	8.8	0.7	6.0	0.4	4.2	ns
t_{PHL}											
t_{PLH}	Bn	An	0.7	7.0	0.4	4.8	0.3	4.5	0.3	4.3	ns
t_{PHL}											
t_{PHZ}	\overline{OE}	An	0.3	5.4	0.3	5.4	0.3	5.4	0.3	5.4	ns
t_{PLZ}											
t_{PHZ}	\overline{OE}	Bn	2.0	28.7	1.6	9.6	1.4	8.0	0.7	5.6	ns
t_{PLZ}											
t_{PZH}	\overline{OE}	An	0.7	6.3	0.7	6.3	0.7	6.3	0.7	6.3	ns
t_{PZL}											
t_{PZH}	\overline{OE}	Bn	1.5	27.6	1.3	11.4	1.0	8.1	0.9	6.0	ns
t_{PZL}											

8.6 Operating Characteristics

 $T_A=25^\circ C$

PARAMETER		TEST CONDITIONS	$V_{CCA}=V_{CCB}=1.8V$	$V_{CCA}=V_{CCB}=2.5V$	$V_{CCA}=V_{CCB}=3.3V$	$V_{CCA}=V_{CCB}=5V$	UNIT
			TYP	TYP	TYP	TYP	
$C_{pdA}^{(1)}$	A-port input, B-port output	$C_L=0,$ $f=10MHz,$ $t_r=t_f=1ns$	2	2	2	3	pF
	B-port input, A-port output		12	13	13	16	
$C_{pdB}^{(1)}$	A-port input, B-port output		13	13	14	16	
	B-port input, A-port output		2	2	2	3	

(1) Power dissipation capacitance per transceiver

8.7 Typical Characteristics

NOTE: The graphs and tables provided following this note are a statistical summary based on a limited number of samples and are provided for informational purposes only.

At $T_A = +25^\circ\text{C}$, $V_{CCA}=5\text{V}$, $V_{CCB}=5\text{V}$, unless otherwise noted.

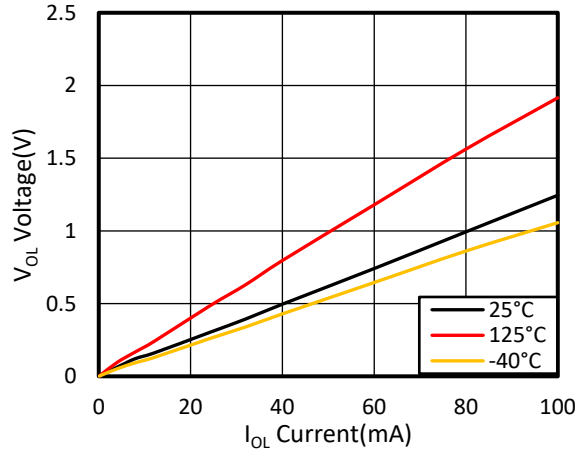

Figure 1. Voltage vs Current

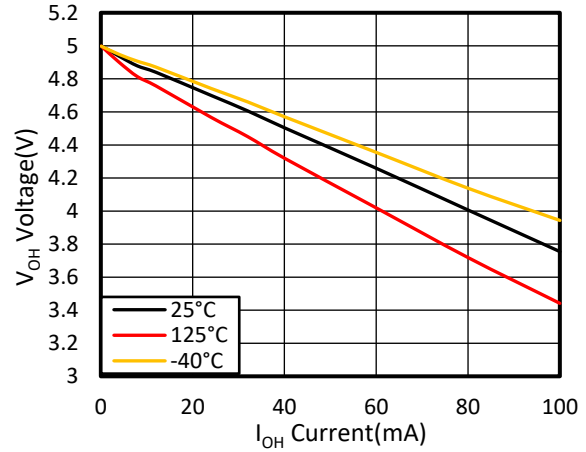
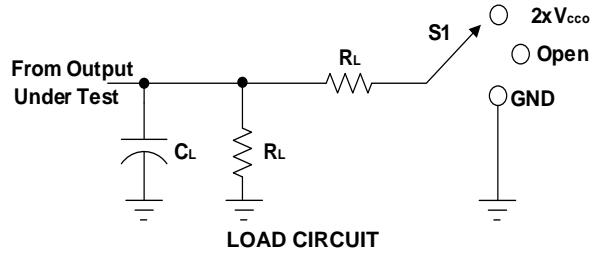

Figure 2. Voltage vs Current

9 Parameter Measurement Information



TEST	S1
t_{pd}	Open
t_{PLZ}/t_{PZL}	$2 \times V_{CCO}$
t_{PHZ}/t_{PZH}	GND

V_{CC}	C_L	R_L	V_{TP}
$1.8V \pm 0.15V$	15pF	2k Ω	0.15V
$2.5V \pm 0.2V$	15pF	2k Ω	0.15V
$3.3V \pm 0.3V$	15pF	2k Ω	0.3V
$5V \pm 0.5V$	15pF	2k Ω	0.3V

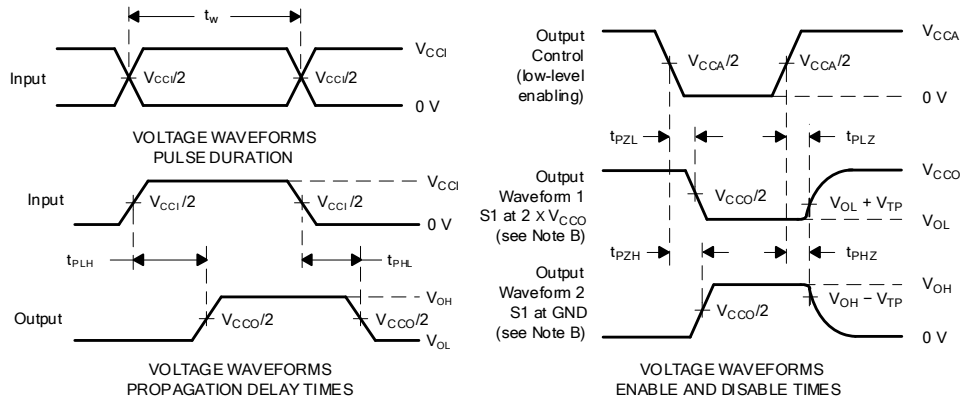

NOTES: A. C_L includes probe and jig capacitance.

B. Waveform 1 is for an output with internal conditions such that the output is low, except when disabled by the output control. Waveform 2 is for an output with internal conditions such that the output is high, except when disabled by the output control.

C. All input pulses are supplied by generators having the following characteristics: $PRR \leq 10$ MHz, $Z_O = 50 \Omega$, $dv/dt \geq 1V/ns$.

D. The outputs are measured one at a time, with one transition per measurement.

E. t_{PLZ} and t_{PHZ} are the same as t_{dis} .

F. t_{PZL} and t_{PZH} are the same as t_{en} .

G. t_{PLH} and t_{PHL} are the same as t_{pd} .

H. All parameters and waveforms are not applicable to all devices.

Figure 3. Load Circuit and Voltage Waveforms

10 Application Information

The RS4T245 device can be used in level-translation applications for interfacing devices or systems operating at different interface voltages with one another. The maximum output current can be up to 32 mA when device is powered by 5 V.

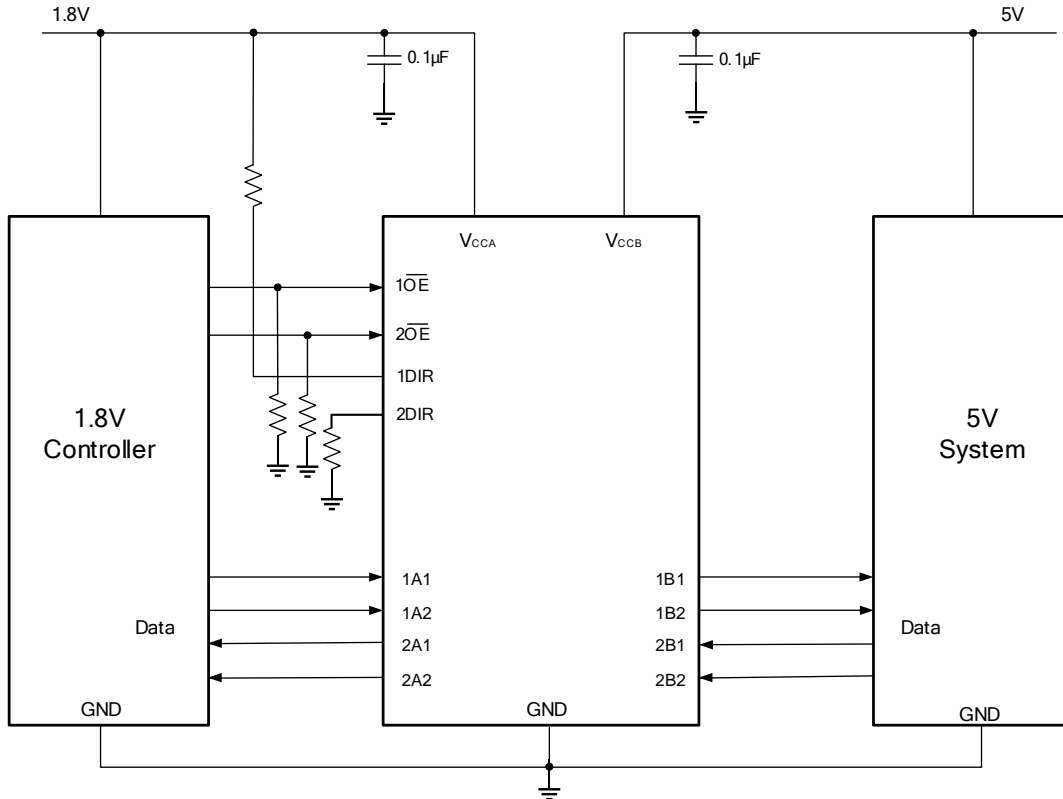
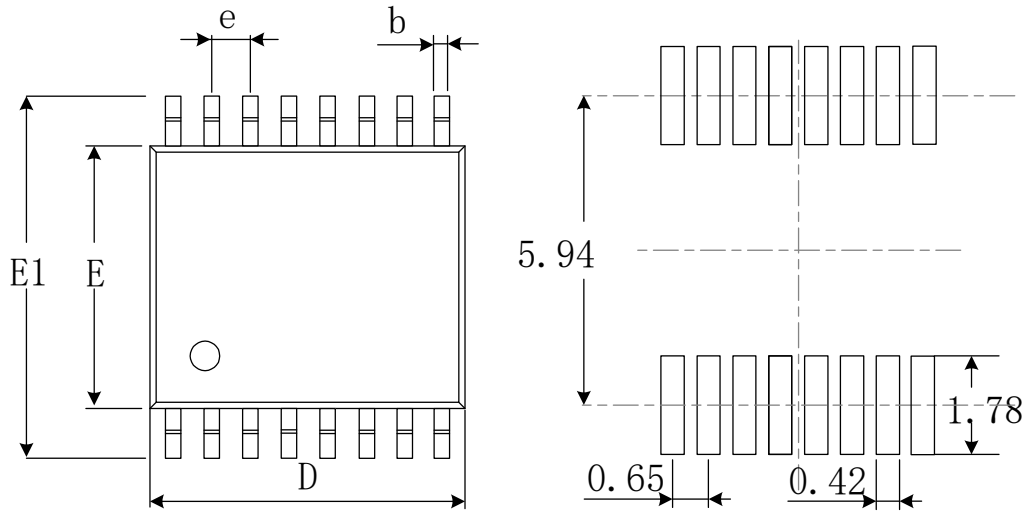
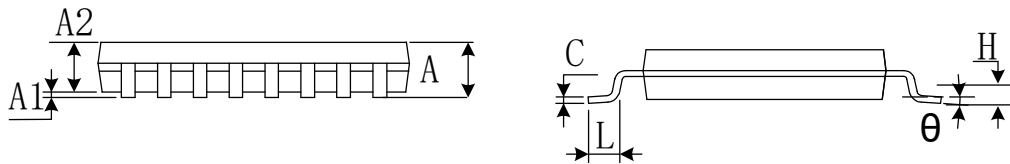
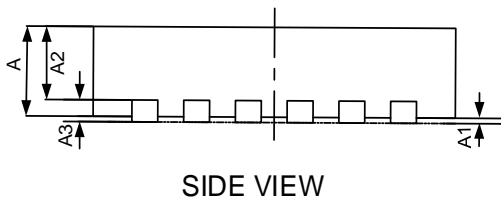
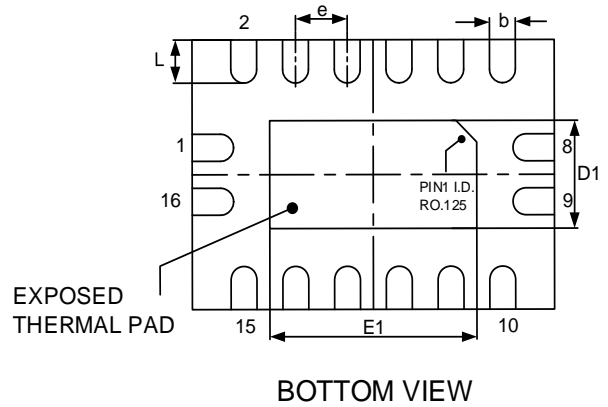
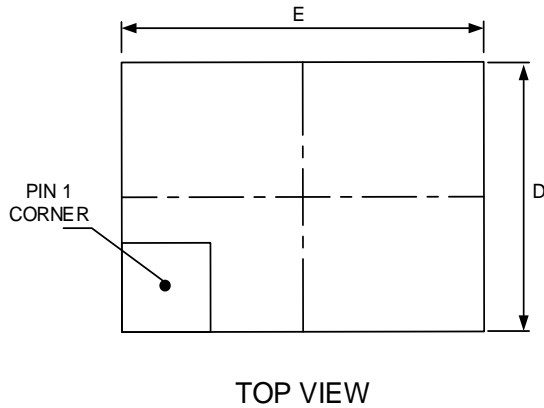

Figure 4. Typical Application Circuit

11 PACKAGE OUTLINE DIMENSIONS
TSSOP-16

RECOMMENDED LAND PATTERN (Unit: mm)

Symbol	Dimensions In Millimeters		Dimensions In Inches	
	Min	Max	Min	Max
A		1.200		0.047
A1	0.050	0.150	0.002	0.006
A2	0.800	1.050	0.031	0.041
b	0.190	0.300	0.007	0.012
c	0.090	0.200	0.004	0.008
D	4.860	5.100	0.191	0.201
E	4.300	4.500	0.169	0.177
E1	6.200	6.600	0.244	0.260
e	0.650(BSC)		0.026(BSC)	
L	0.500	0.700	0.02	0.028
H	0.250 TYP		0.010 TYP	
θ	1°	7°	1°	7°

QFN2.5x3.5-16L

Symbol	Dimensions In Millimeters		Dimensions In Inches	
	Min	Max	Min	Max
A	0.800	1.000	0.031	0.039
A1	0.000	0.050	0.000	0.002
A2	0.600	0.700	0.024	0.028
A3	0.203(REF)		0.008(REF)	
D	2.400	2.600	0.094	0.102
E	3.400	3.600	0.134	0.142
e	0.500(BSC)		0.020(BSC)	
b	0.180	0.300	0.007	0.012
L	0.300	0.500	0.012	0.020
D1	0.850	1.150	0.033	0.045
E1	1.850	2.150	0.073	0.085

NOTE:

- A. All linear dimension is in millimeters.
- B. This drawing is subject to change without notice.
- C. Body dimensions do not include mold flash or protrusion. Mold flash and protrusion shall not exceed 0.15 per side.
- D. BSC: Basic Dimension. Theoretically exact value shown without tolerances.
- E. REF: Reference Dimension, usually without tolerance, for information purposes only.

12 TAPE AND REEL INFORMATION

REEL DIMENSIONS

TAPE DIMENSION

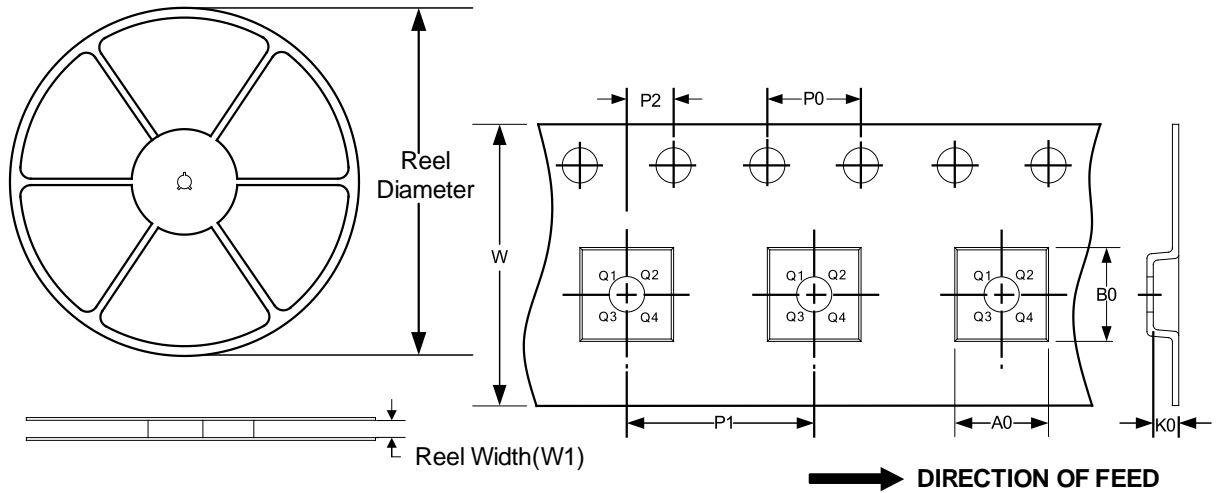

NOTE: The picture is only for reference. Please make the object as the standard.

KEY PARAMETER LIST OF TAPE AND REEL

Package Type	Reel Diameter	Reel Width (mm)	A0 (mm)	B0 (mm)	K0 (mm)	P0 (mm)	P1 (mm)	P2 (mm)	W (mm)	Pin1 Quadrant
TSSOP16	13"	12.4	6.90	5.60	1.20	4.0	8.0	2.0	12.0	Q1
QFN2.5x3.5-16L	7"	15.0	2.80	3.80	1.20	4.0	4.0	2.0	12.0	Q1

NOTE:

1. All dimensions are nominal.
2. Plastic or metal protrusions of 0.15mm maximum per side are not included.

IMPORTANT NOTICE AND DISCLAIMER

Jiangsu Runic Technology Co., Ltd. will accurately and reliably provide technical and reliability data (including data sheets), design resources (including reference designs), application or other design advice, WEB tools, safety information and other resources, without warranty of any defect, and will not make any express or implied warranty, including but not limited to the warranty of merchantability Implied warranty that it is suitable for a specific purpose or does not infringe the intellectual property rights of any third party.

These resources are intended for skilled developers designing with Runic products You will be solely responsible for: (1) Selecting the appropriate products for your application; (2) Designing, validating and testing your application; (3) Ensuring your application meets applicable standards and any other safety, security or other requirements; (4) Runic and the Runic logo are registered trademarks of Runic Incorporated. All trademarks are the property of their respective owners; (5) For change details, review the revision history included in any revised document. The resources are subject to change without notice. Our company will not be liable for the use of this product and the infringement of patents or third-party intellectual property rights due to its use.