

Dual SPST Depletion Mode Isolation Switch

1 FEATURES

- Dual SPST Depletion Switch
- Normally Closed when $V_{CC} < 0.2V$
- Switches Configurable through Select Pins
- Signal Range: $-1.5V$ to $+1.5V$
- Low ON-State Resistance: 0.5Ω (TYP)
- R_{ON} Flat: 0.01Ω (TYP)
- Port Off Isolation: $-70dB$ (TYP)
- THD+N: $-102dB$ (TYP)
- Extended Industrial Temperature Range: $-40^{\circ}C$ to $+85^{\circ}C$
- Available in Green WLCSP1.385X1.215-9、DFN3X3-8 Package

2 APPLICATIONS

- Headphones
- Portable Media Players

3 DESCRIPTIONS

The RS553 is a high-performance dual single-pole single-throw (SPST x 2) audio switch. The depletion technology allows the device to conduct signals when there is no V_{CC} available and to isolate signals when V_{CC} is present. During signal conduction, the depletion gate control allows the RS553 to achieve excellent THD+N performance while consuming minimal power.

RS553 is available in the Green DFN3X3-8 and WLCSP1.385X1.215-9 package. It is rated over the $-40^{\circ}C$ to $+85^{\circ}C$ temperature range.

Device Information ⁽¹⁾

PART NUMBER	PACKAGE	BODY SIZE (NOM)
RS553	DFN3X3-8	3.00mmx3.00mm
	WLCSP1.385X1.215-9	1.385mmx1.215mm

(1) For all available packages, see the orderable addendum at the end of the data sheet.

4 Typical Application Circuit

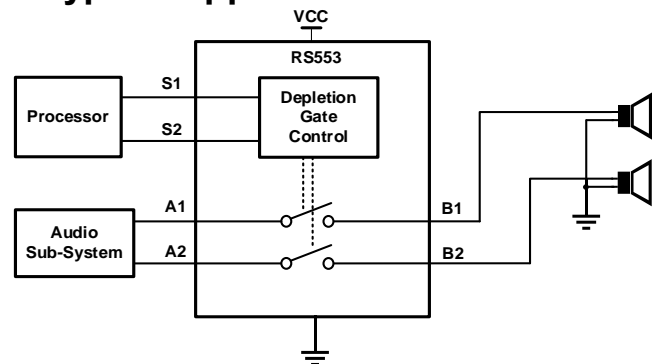

Table of Contents

1 FEATURES	1
2 APPLICATIONS	1
3 DESCRIPTIONS	1
4 Typical Application Circuit	1
5 Revision History	3
6 PACKAGE/ORDERING INFORMATION ⁽¹⁾	4
7 PIN CONFIGURATIONS	5
8 SPECIFICATIONS	7
8.1 Absolute Maximum Ratings	7
8.2 Recommended Operating Conditions	7
8.3 ESD Ratings	7
8.4 ELECTRICAL CHARACTERISTICS	8
8.5 Timing Diagrams	10
8.6 TYPICAL CHARACTERISTICS	11
9 PACKAGE OUTLINE DIMENSIONS	12
10 TAPE AND REEL INFORMATION	14

5 Revision History

Note: Page numbers for previous revisions may differ from page numbers in the current version.

VERSION	Change Date	Change Item
A.1	2022/07/04	1.Added of WLCSP1.385X1.215-9 package 2.Fixed error of PACKAGE OUTLINE DIMENSION 3.Added PACKAGE/ORDERING INFORMATION
A.2	2023/02/21	Added ESD Ratings
A.2.1	2024/02/23	Modify packaging naming

6 PACKAGE/ORDERING INFORMATION ⁽¹⁾

PRODUCT	ORDERING NUMBER	TEMPERATURE RANGE	PACKAGE LEAD	PACKAGE MARKING ⁽²⁾	PACKAGE OPTION
RS553	RS553YUC9	-40°C ~ 85°C	WLCSP1.385X1.215-9	RS553	Tape and Reel,3000
	RS553YTDC8	-40°C ~ 85°C	DFN3X3-8	RS553	Tape and Reel,5000

NOTE:

- (1) This information is the most current data available for the designated devices. This data is subject to change without notice and revision of this document. For browser-based versions of this data sheet, refer to the right-hand navigation.
- (2) There may be additional marking, which relates to the lot trace code information(data code and vendor code), the logo or the environmental category on the device.

7 PIN CONFIGURATIONS

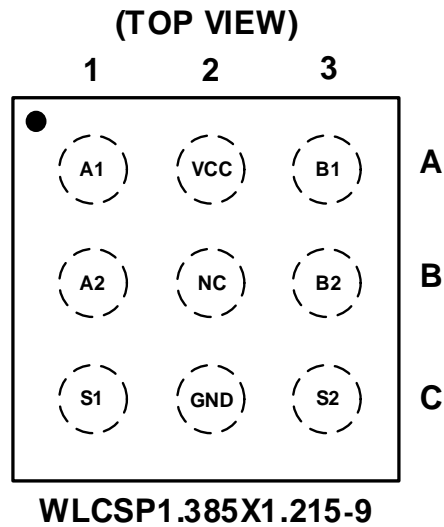

PIN DESCRIPTION

PIN#	NAME	TYPE ⁽¹⁾	DESCRIPTION
A1	A1	I/O	A-Port of Switch1 (Normally Closed)
B1	A2	I/O	A-Port of Switch2 (Normally Closed)
C1	S1	I/O	Select to Enable/Disable Switch1 (Enable Low)
A2	VCC	P	Supply Voltage
B2	NC	X	No Connect
C2	GND	G	Ground
A3	B1	I/O	B-Port of Switch1 (Normally Closed)
B3	B2	I/O	B-Port of Switch2 (Normally Closed)
C3	S2	I/O	Select to Enable/Disable Switch2 (Enable Low)

(1) I=Input, O=Output, P=Power

PIN CONFIGURATIONS

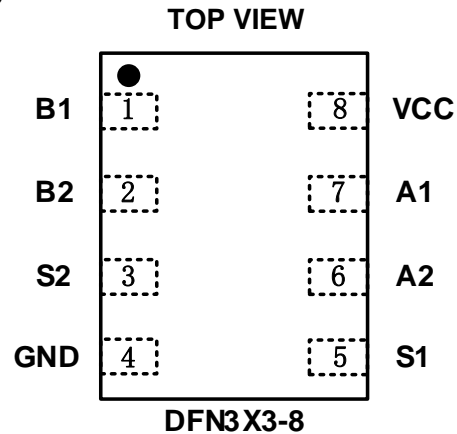

PIN DESCRIPTION

PIN#	NAME	TYPE ⁽¹⁾	DESCRIPTION
1	B1	I/O	B-Port of Switch1 (Normally Closed)
2	B2	I/O	B-Port of Switch2 (Normally Closed)
3	S2	I/O	Select to Enable/Disable Switch2 (Enable Low)
4	GND	G	Ground
5	S1	I/O	Select to Enable/Disable Switch1 (Enable Low)
6	A2	I/O	A-Port of Switch2 (Normally Closed)
7	A1	I/O	A-Port of Switch1 (Normally Closed)
8	V _{CC}	P	Supply Voltage

(1) I=Input, O=Output, P=Power

Table 1. Switch Truth Table

V _{CC}	S1	S2	Switch 1	Switch 2
Low	X	X	ON	ON
High	High	High	OFF	OFF
High	Low	High	ON	OFF
High	High	Low	OFF	ON

8 SPECIFICATIONS

8.1 Absolute Maximum Ratings

Over operating free-air temperature range (unless otherwise noted) ⁽¹⁾

SYMBOL	PARAMETER		MIN	MAX	UNIT
V _{CC}	Supply/Control Voltage,		-0.5	4.3	V
V _{IN}	Input Voltage (Select Pins S1, S2)		-0.5	4.3	
V _{SW(ON)}	DC Switch I/O Voltage (Switch Conducting)	A1, B1, A2, B2	-2.0	+2.0	
V _{SW(OFF)} ⁽²⁾	DC Switch I/O Voltage (Switch Isolated)	A1, B1, A2, B2	-1.8	V _{CC}	
I _{SW}	Switch I/O Current	V _{CC} =0V (Switch Conducting)		350	mA
I _{SWPEAK}	Peak Switch Current	Pulsed at 1ms Duration, <10% Duty Cycle		500	
T _A	Absolute Maximum Operating Temperature		-40	+85	°C
T _J	Junction Temperature		-40	+150	
T _{stg}	Storage Temperature		-65	+150	

(1) Stresses above these ratings may cause permanent damage. Exposure to absolute maximum conditions for extended periods may degrade device reliability. These are stress ratings only, and functional operation of the device at these or any other conditions beyond those specified is not implied.

(2) When a switch is isolated (OFF), V_{SW} value must be < V_{CC}.

8.2 Recommended Operating Conditions

Over operating free-air temperature range (unless otherwise noted) ⁽³⁾

SYMBOL	PARAMETER		MIN	MAX	UNIT
V _{CC(ON)}	Supply Voltage with Switch Conducting (1A=1B; 2A=2B)		0	0.2	V
V _{CC(OFF)}	Supply Voltage with Switch Isolated (1A≠1B; 2A≠2B);		1.5	3.0	V
V _{SW(ON)}	DC Switch I/O Voltage (Switch Conducting)	V _{CC} =0V	-1.5	+1.5	V
V _{SW(OFF)}	DC Switch I/O Voltage (Switch Isolated)	V _{CC} =1.6V to 3.0V	-1.5	+1.5	V
V _{IN}	Input Voltage (Select Pins S1, S2)		0	3	V

(3) The Recommended Operating Condition table defines the conditions for actual device operation. Recommended operating condition are specified to ensure optimal performance to the datasheet specifications.

8.3 ESD Ratings

The following ESD information is provided for handling of ESD-sensitive devices in an ESD protected area only.

			VALUE	UNIT
V _(ESD)	Electrostatic discharge	Human-body model (HBM), per ANSI/ESDA/JEDEC JS-001 ⁽¹⁾	±4000	V
		Charged-device model (CDM), per ANSI/ESDA/JEDEC JS-002 ⁽²⁾	±1000	
		Machine Model (MM)	±400	

(1) JEDEC document JEP155 states that 500 V HBM allows safe manufacturing with a standard ESD control process.

(2) JEDEC document JEP157 states that 250 V CDM allows safe manufacturing with a standard ESD control process.



ESD SENSITIVITY CAUTION

ESD damage can range from subtle performance degradation to complete device failure. Precision integrated circuits may be more susceptible to damage because very small parametric changes could cause the device not to meet its published specifications.

8.4 ELECTRICAL CHARACTERISTICS

Full=-40°C ~+85°C, Typical values at T_A = 25°C unless otherwise specified ⁽¹⁾.

PARAMETER	SYMBOL	CONDITIONS	V _{CC} (V)	T _A	MIN (2)	TYP (3)	MAX (2)	UNIT		
DC Electrical Characteristics										
Supply Voltage Hysteresis	V _{CC(HYS)}			+25°C		30		mV		
Switch-to-GND Leakage Current (Switch Conducting)	I _{ON}	An=-1.5V~1.5V, Bn=Sn=Float	0	Full		0.1		μA		
Switch-to-GND Leakage Current (Switch Isolated)	I _{OFF}	An=-1.5V~1.5V, Bn=GND, Sn=V _{CC}	1.8	Full		0.5		μA		
Increase in I _{CC} for each Select Pin	I _{CC}	S1=V _{CC} , S2=1.2V	3	Full		5.5		μA		
		S1=1.2V, S2=V _{CC}	3	Full		5.5		μA		
Switch On Resistance ⁽⁴⁾	R _{ON}	I _{SW} =100mA, V _{SW} =-1.5V to +1.5V	0	Full		0.5		Ω		
Switch On Resistance Difference, Channel to Channel	ΔR _{ON}		0	Full		0.01		Ω		
On Resistance Flatness ⁽⁴⁾	R _{FLAT(ON)}		0	Full		0.01		Ω		
V _{CC} Pull-Down Resistance	R _{PD}		<0.2	Full		1.5		MΩ		
Select Pull-Up Resistance	R _{PU}		<0.2	Full		2		MΩ		
Quiescent Supply Current	I _{CC}	S1=S2= 0V or Float	Switch Isolated	3	Full		30		μA	
			Switch Conducting	0.2	Full		0.1		μA	
Input Voltage High (Select Pins) ⁽⁵⁾	V _{IH}		3	Full	1.2			V		
Input Voltage Low (Select Pins) ⁽⁵⁾	V _{IL}		3	Full			0.5	V		
AC Electrical Characteristics										
Turn-On Time V _{CC} to Output ^(6,7)	t _{ON}	R _L =33Ω, C _L =8.2pF, S1=S2=Float, V _{SW} =1.5V	1.8~0	+25°C		1.3		μs		
		R _L =33Ω, C _L =8.2pF, S1=S2=Float, V _{SW} =-1.5V	1.8~0	+25°C		45		μs		
Turn-Off Time V _{CC} to Output ^(6,7)	t _{OFF}	R _L =33Ω, C _L =8.2pF, S1=S2=Float, V _{SW} =1.5V	0~1.8	+25°C		100		μs		
		R _L =33Ω, C _L =8.2pF, S1=S2=Float, V _{SW} =-1.5V	0~1.8	+25°C		130		μs		
Turn-On Time Select Pin	t _{ONS}	R _L =33Ω, C _L =8.2pF, S1=S2=V _{CC} ~0, V _{SW} =1.5V	1.8	+25°C		180		μs		
		R _L =33Ω, C _L =8.2pF, S1=S2=V _{CC} ~0, V _{SW} =-1.5V	1.8	+25°C		180		μs		
Turn-Off Time Select Pin	t _{OFFS}	R _L =33Ω, C _L =8.2pF, S1=S2=0~V _{CC} , V _{SW} =1.5V	1.8	+25°C		35		μs		
		R _L =33Ω, C _L =8.2pF, S1=S2=0~V _{CC} , V _{SW} =-1.5V	1.8	+25°C		70		μs		
Off Isolation ^(6,7)	O _{IRR}	R _L =32 Ω, f=50k~100 kHz	1.8	+25°C		-70		dB		
Cross talk ^(6,7)	X _{TALK}	R _L =32 Ω, f=100kHz	1.8	+25°C		-85		dB		
Power Supply Rejection Ratio	PSRR	Switch Isolating, V _{ripple} =V _{CC} +300mV p-p, R _L =32Ω	217Hz	1.8	Full		-80	dB		
			1 kHz						Full	-77
			20 kHz							
-3dB Bandwidth ⁽⁶⁾	BW	R _L =47Ω, C _L =56pF	0	+25°C		200		MHZ		
Total Harmonic Distortion + Noise ^(6,7)	THD+N	R _L =50Ω, f=1kHz, V _{SW} =1V _{RMS}	0	+25°C		-102		dB		

ON Capacitance	C_{ON}	$V_{SW}=400mV_{PP}, f=1MHz$	0	Full		20		pF
OFF Capacitance	C_{OFF}	$V_{SW}=400mV_{PP}, f=1MHz,$ $S1=S2=V_{CC}$	1.8	Full		25		pF
Select Pin Capacitance	C_{CTRL}	$S1=S2=400mV_{PP}, f=1MHz$	1.8	Full		5		pF

- (1) Electrical table values apply only for factory testing conditions at the temperature indicated. Factory testing conditions result in very limited self-heating of the device.
- (2) Limits are 100% production tested at 25°C. Limits over the operating temperature range are ensured through correlations using statistical quality control (SQC) method.
- (3) Typical values represent the most likely parametric norm as determined at the time of characterization. Actual typical values may vary over time and will also depend on the application and configuration.
- (4) Guaranteed by test and characterization.
- (5) Voltages on select control pins must be $<V_{CC}$.
- (6) $S1=S2=LOW$.
- (7) Guaranteed by characterization.

8.5 Timing Diagrams

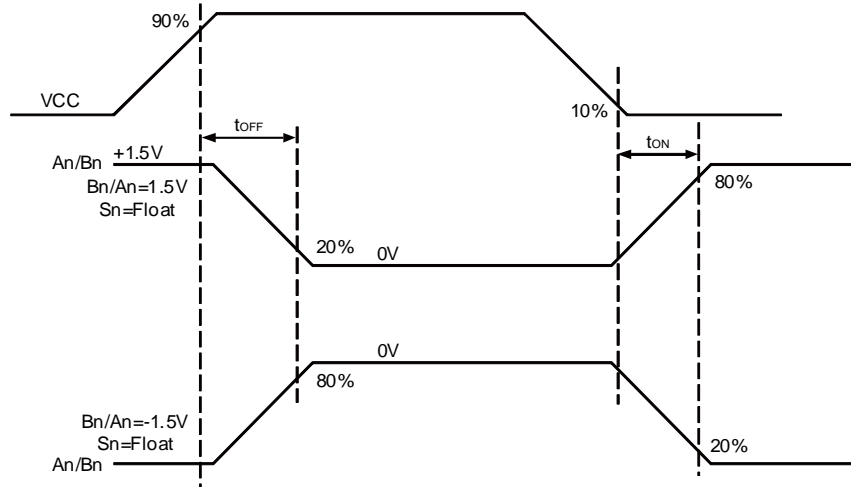

Figure1. t_{ON}/t_{OFF} V_{CC} to Output Timing

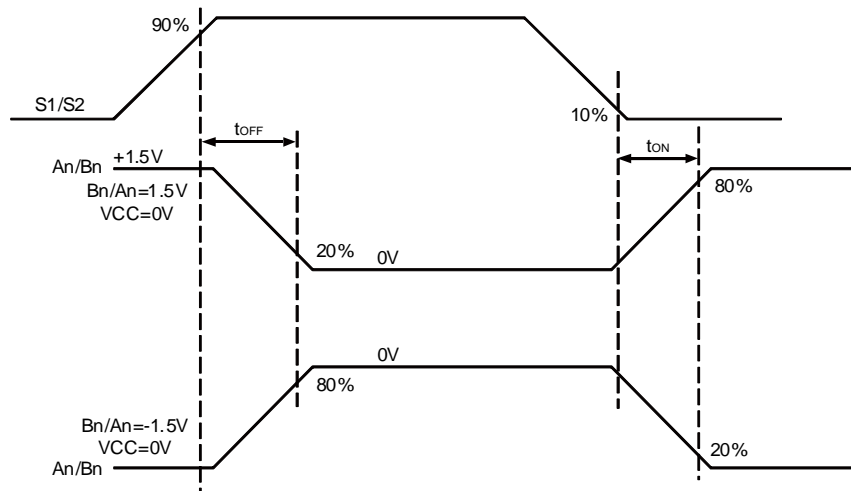

Figure 2. t_{ON}/t_{OFF} Select (S_n) to Output Timing

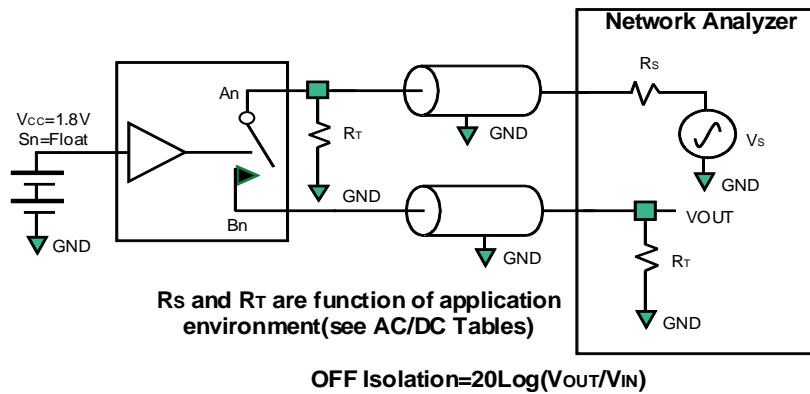

Figure 3. OFF Isolation

8.6 TYPICAL CHARACTERISTICS

NOTE: The graphs and tables provided following this note are a statistical summary based on a limited number of samples and are provided for informational purposes only.

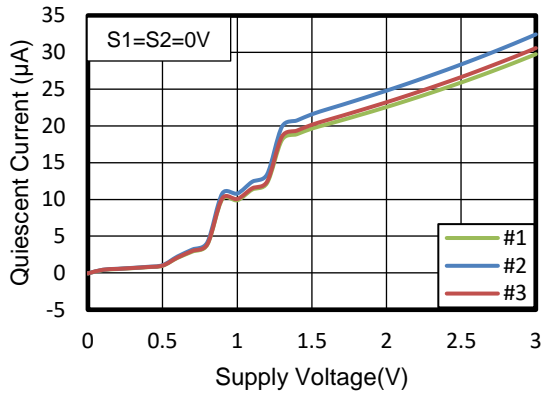

Figure 4. Quiescent Current vs Supply Voltage

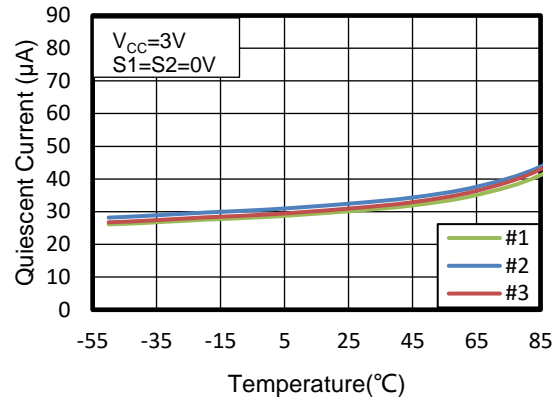

Figure 5. Quiescent Current vs Temperature

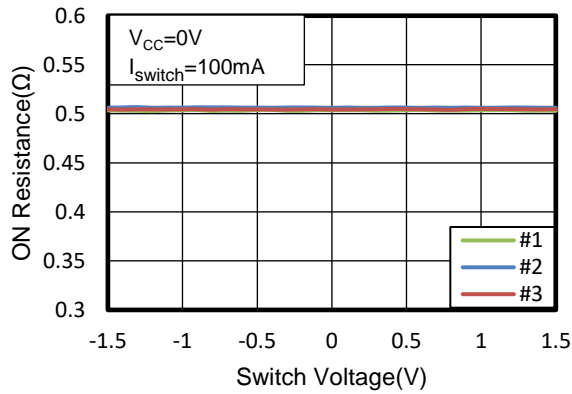

Figure 6. ON Resistance vs Switch Voltage

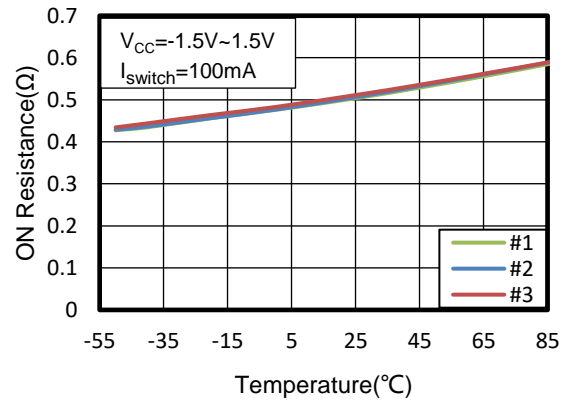
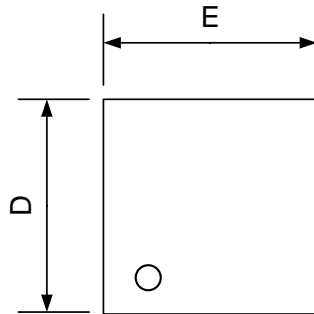

Figure 7. ON Resistance vs Temperature

9 PACKAGE OUTLINE DIMENSIONS

DFN3X3-8



TOP VIEW

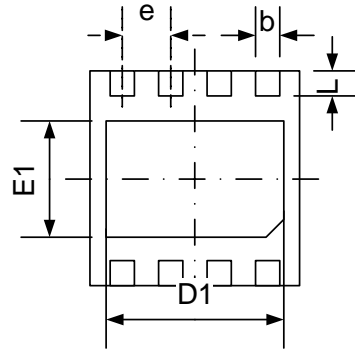

BOTTOM VIEW

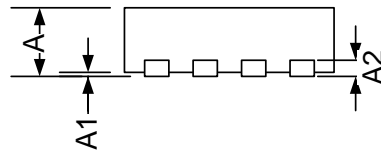

SIDE VIEW

Symbol	Dimensions In Millimeters		Dimensions In Inches	
	Min	Max	Min	Max
A	0.700	0.800	0.028	0.031
A1	0.000	0.050	0.000	0.002
A2	0.203		0.008	
b	0.300	0.400	0.012	0.016
D	2.900	3.100	0.114	0.122
D1	2.510	2.610	0.099	0.103
E	2.900	3.100	0.114	0.122
E1	1.550	1.650	0.061	0.065
e	0.650 TYP		0.026 TYP	
L	0.350	0.450	0.014	0.018

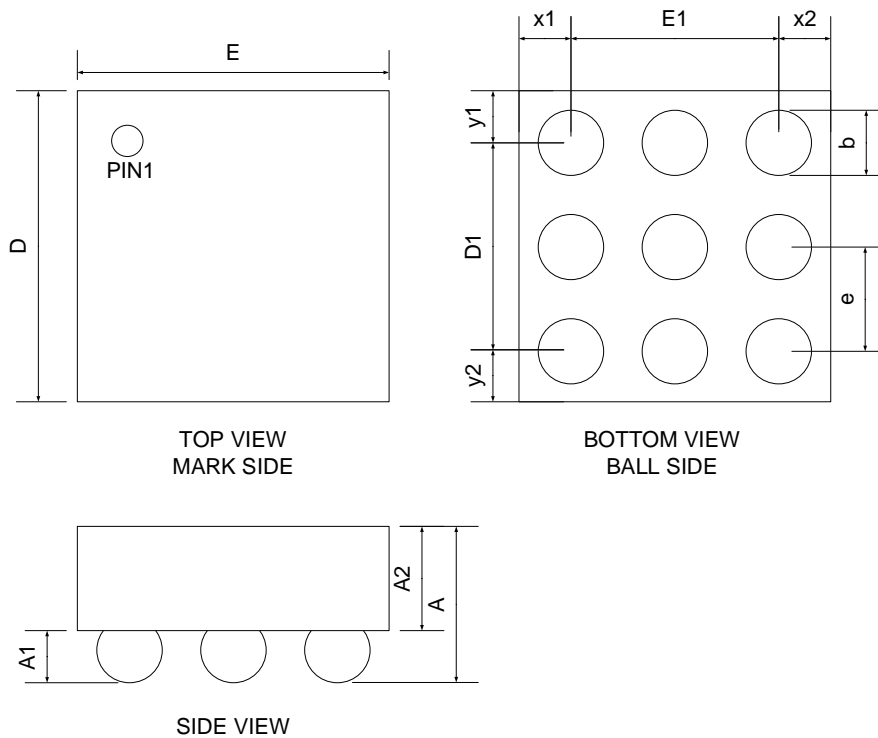
WLCSP1.385X1.215-9

NOTES: ALL WAFER ORIENTATION NOTCH DOWN

SYMBOL	Dimensions In Millimeters			Dimensions In Inches		
	MIN	NOM	MAX	MIN	NOM	MAX
A	0.541	0.581	0.624	0.021	0.023	0.025
A1	0.183	0.203	0.223	0.007	0.008	0.009
A2	0.358	0.378	0.398	0.014	0.015	0.016
D	1.365	1.385	1.405	0.054	0.055	0.056
D1	0.800(BSC)			0.031(BSC)		
E	1.195	1.215	1.235	0.047	0.048	0.049
E1	0.800(BSC)			0.031(BSC)		
b	0.230	0.260	0.290	0.010	0.011	0.012
e	0.400(BSC)			0.016(BSC)		
x1	0.2075(REF)			0.008(REF)		
x2	0.2075(REF)			0.008(REF)		
y1	0.2925(REF)			0.012(REF)		
y2	0.2925(REF)			0.012(REF)		

NOTE:

- A. All linear dimension is in millimeters.
- B. This drawing is subject to change without notice.
- C. Body dimensions do not include mold flash or protrusion. Mold flash and protrusion shall not exceed 0.15 per side.
- D. BSC: Basic Dimension. Theoretically exact value shown without tolerances.
- E. REF: Reference Dimension, usually without tolerance, for information purposes only.

10 TAPE AND REEL INFORMATION

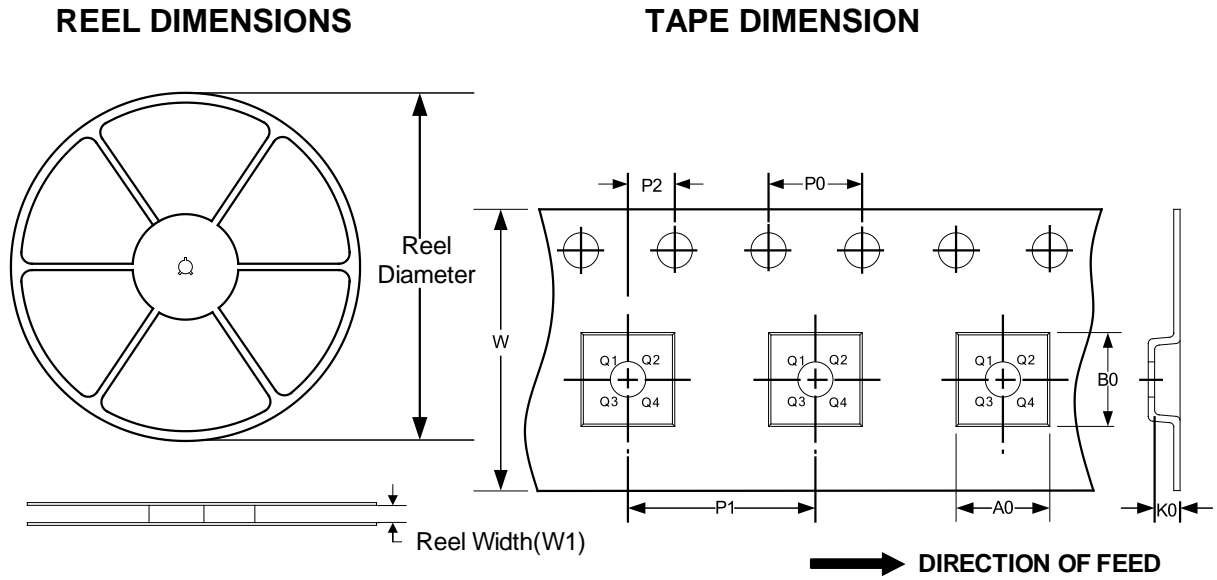

NOTE: The picture is only for reference. Please make the object as the standard.

KEY PARAMETER LIST OF TAPE AND REEL

Package Type	Reel Diameter	Reel Width(mm)	A0 (mm)	B0 (mm)	K0 (mm)	P0 (mm)	P1 (mm)	P2 (mm)	W (mm)	Pin1 Quadrant
DFN3X3-8	13"	12.4	3.35	3.35	1.13	4.0	8.0	2.0	12.0	Q1
WLCSP1.385X1.215-9	7"	8.4	1.30	1.47	0.72	4.0	4.0	2.0	8.0	Q1

NOTE:

1. All dimensions are nominal.
2. Plastic or metal protrusions of 0.15mm maximum per side are not included.

IMPORTANT NOTICE AND DISCLAIMER

Jiangsu Runic Technology Co., Ltd. will accurately and reliably provide technical and reliability data (including data sheets), design resources (including reference designs), application or other design advice, WEB tools, safety information and other resources, without warranty of any defect, and will not make any express or implied warranty, including but not limited to the warranty of merchantability Implied warranty that it is suitable for a specific purpose or does not infringe the intellectual property rights of any third party.

These resources are intended for skilled developers designing with Runic products You will be solely responsible for: (1) Selecting the appropriate products for your application; (2) Designing, validating and testing your application; (3) Ensuring your application meets applicable standards and any other safety, security or other requirements; (4) Runic and the Runic logo are registered trademarks of Runic Incorporated. All trademarks are the property of their respective owners; (5) For change details, review the revision history included in any revised document. The resources are subject to change without notice. Our company will not be liable for the use of this product and the infringement of patents or third-party intellectual property rights due to its use.