

Dual 5A High-Speed, Low-Side Gate Driver

1 FEATURES

- **Industry-Standard Pinout**
- **Two Independent Gate-Drive Channels**
- **5A Peak Source and Sink-Drive Current**
- **TTL and CMOS Compatible Logic Threshold Independent of Supply Voltage**
- **Hysteretic-Logic Thresholds for High Noise Immunity**
- **Inputs Pin-Voltage Levels Not Restricted by VDD Pin Bias Supply Voltage**
- **4.5V to 18V Single-Supply Range**
- **Outputs Held Low During VDD-UVLO, (Ensures Glitch-Free Operation at Power up and Power Down)**
- **Fast Propagation Delays (13ns Typical)**
- **Fast Rise and Fall Times (7ns and 6ns Typical)**
- **Two Outputs are in Parallel for Higher Drive Current**
- **Outputs Held Low When Inputs Floating**
- **Operating Temperature Range of -40°C to 140°C**
- **Micro SIZE PACKAGES: SOP8**

2 APPLICATIONS

- **Switched-Mode Power Supplies**
- **DC-DC Converters**
- **Motor Control, Solar Power**
- **Gate Drive for Emerging Wide Band-Gap Power Devices such as GaN**

3 DESCRIPTIONS

The RS8802 dual-channel, high-speed, low-side gate driver device is capable of effectively driving MOSFET and IGBT power switches. Using a design that inherently minimizes shoot-through current, the RS8802 is capable of sourcing and sinking high peak-current pulses into capacitive loads offering rail-to-rail drive capability and extremely small propagation delay typically 13ns.

The RS8802 device is capable of handling -4V at input. In addition, the drivers feature matched internal propagation delays between the two channels, these delays are very well suited for applications requiring dual-gate drives with critical timing, such as synchronous rectifiers. This also enables connecting two channels in parallel to effectively increase current-drive capability or driving two switches in parallel with one input signal.

The RS8802 provides 5A source and 5A sink (symmetrical drive) peak-drive current capability at VDD = 12V.

The RS8802 is designed to operate over a wide VDD range of 4.5 V to 18 V and wide temperature range of -40°C to 140°C. Internal Undervoltage Lockout (UVLO) circuitry on VDD pin holds output low outside VDD operating range. The capability to operate at low voltage levels such as below 5V, along with best-in-class switching characteristics, is especially suited for driving emerging wide band-gap power-switching devices as GaN power semiconductor devices.

Device Information ⁽¹⁾

PART NUMBER	PACKAGE	BODY SIZE (NOM)
RS8802	SOP8	4.90mm×3.90mm

(1) For all available packages, see the orderable addendum at the end of the data sheet.

4 Typical Application Diagrams

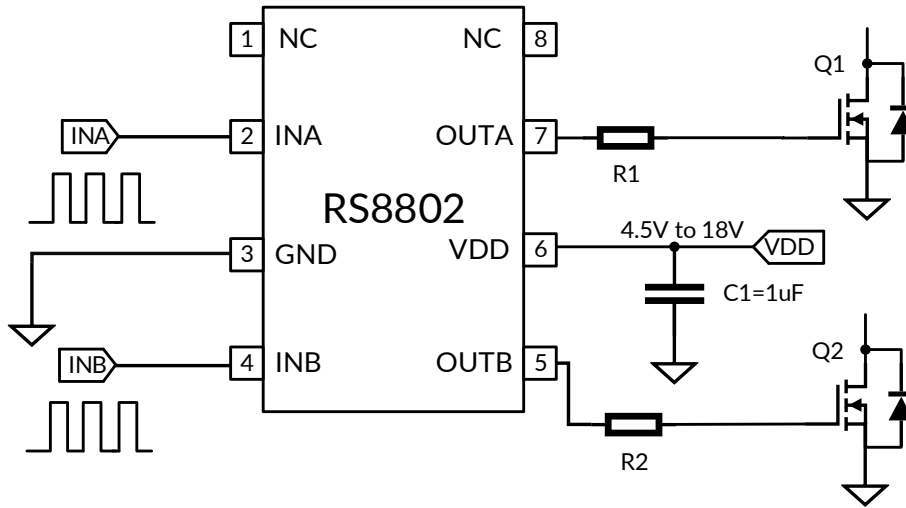

Table of Contents

1 FEATURES	1
2 APPLICATIONS	1
3 DESCRIPTIONS	1
4 Typical Application Diagrams	2
5 Revision History	4
6 PACKAGE/ORDERING INFORMATION ⁽¹⁾	5
7 Pin Configuration and Functions (Top View)	6
8 SPECIFICATIONS	7
8.1 Absolute Maximum Ratings	7
8.2 ESD Ratings	7
8.3 Recommended Operating Conditions	7
8.4 ELECTRICAL CHARACTERISTICS	8
8.5 TYPICAL PERFORMANCE CHARACTERISTICS	10
9 Detailed Description	13
9.1 Overview	13
9.2 Functional Block Diagram	13
9.3 V _{DD} and Undervoltage Lockout	14
9.4 Device Functional Modes	14
10 Power Supply Recommendations	15
11 Layout	15
12 PACKAGE OUTLINE DIMENSIONS	16
13 TAPE AND REEL INFORMATION	17

5 Revision History

Note: Page numbers for previous revisions may differ from page numbers in the current version.

VERSION	Change Date	Change Item
A.1	2023/12/22	Initial version completed
A.1.1	2024/02/23	Modify packaging naming

6 PACKAGE/ORDERING INFORMATION (1)

Orderable Device	Package Type	Op Temp(°C)	Device Marking (2)	MSL (3)	Package Qty
RS8802HXK	SOP8	-40°C ~+140°C	RS8802	MSL1	Tape and Reel,4000

NOTE:

- (1) This information is the most current data available for the designated devices. This data is subject to change without notice and revision of this document. For browser-based versions of this data sheet, refer to the right-hand navigation.
- (2) There may be additional marking, which relates to the lot trace code information (data code and vendor code), the logo or the environmental category on the device.
- (3) MSL, The Moisture Sensitivity Level rating according to the JEDEC industry standard classifications.

7 Pin Configuration and Functions (Top View)

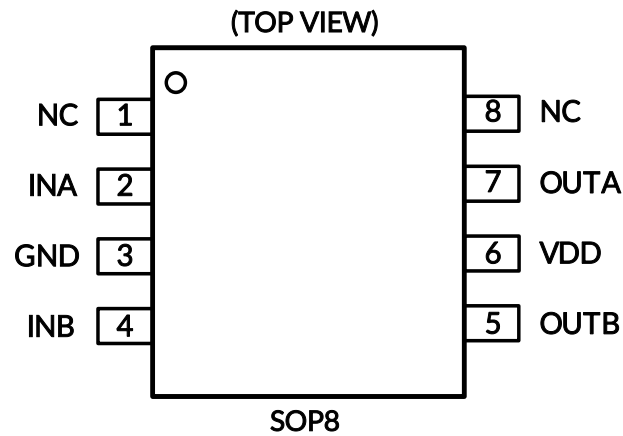

Pin Description

SOP8		I/O ⁽¹⁾	DESCRIPTION
NUMBER	NAME		
1	NC	--	No connection
2	INA	I	Input to channel A. OUTA held LOW if INA is unbiased or floating.
3	GND	G	Ground
4	INB	I	Input to channel B. OUTB held LOW if INB is unbiased or floating.
5	OUTB	O	Output of Channel B
6	VDD	P	Supply input.
7	OUTA	O	Output of Channel A
8	NC	--	No connection

(1) I=input, O=output, G= Ground.

8 SPECIFICATIONS

8.1 Absolute Maximum Ratings

over operating free-air temperature range (unless otherwise noted) ⁽¹⁾ ⁽²⁾ ⁽³⁾

		MIN	MAX	UNIT
Supply voltage	VDD	-0.3	22	V
OUT voltage	DC	-0.3	VDD+0.3	V
	Repetitive pulse less than 200ns ⁽⁴⁾	-2	VDD+0.3	
Output continuous current	I _{OUT_DC} (Source/Sink)		0.4	A
Output pulsed current (0.5us)	I _{OUT_pulsed} (Source/Sink)		5	A
Input voltage	INA, INB ⁽⁵⁾	-4	22	V
θ _{JA}	Package thermal impedance ⁽⁶⁾		110	°C/W
T _J operating virtual junction temperature range ⁽⁷⁾		-40	150	°C
Storage Temperature Range		-65	150	°C
Lead Temperature (Soldering, 10s)			260	°C

- (1) Stresses beyond those listed under absolute maximum ratings may cause permanent damage to the device. These are stress ratings only and functional operation of the device at these or any other conditions beyond those indicated under recommended operating conditions is not implied. Exposure to absolute-maximum-rated conditions for extended periods may affect device reliability.
- (2) All voltages are with respect to GND unless otherwise noted. Currents are positive into, negative out of the specified terminal. See Packaging Section of the datasheet for thermal limitations and considerations of packages.
- (3) These devices are sensitive to electrostatic discharge; follow proper device-handling procedures.
- (4) Values are verified by characterization on bench.
- (5) Maximum voltage on input pins is not restricted by the voltage on the VDD pin.
- (6) The package thermal impedance is calculated in accordance with JESD-51.
- (7) The maximum power dissipation is a function of T_{J(MAX)}, R_{θJA}, and T_A. The maximum allowable power dissipation at any ambient temperature is P_D = (T_{J(MAX)} - T_A) / R_{θJA}. All numbers apply for packages soldered directly onto a PCB.

8.2 ESD Ratings

The following ESD information is provided for handling of ESD-sensitive devices in an ESD protected area only.

		VALUE	UNIT
V _(ESD)	Electrostatic discharge	Human-Body Model (HBM), MIL-STD-883K METHOD 3015.9	±3000
		Charged-Device Model (CDM), ANSI/ESDA/JEDEC JS-002-2018	±1000



ESD SENSITIVITY CAUTION

ESD damage can range from subtle performance degradation to complete device failure. Precision integrated circuits may be more susceptible to damage because very small parametric changes could cause the device not to meet its published specifications.

8.3 Recommended Operating Conditions

over operating free-air temperature range (unless otherwise noted)

	MIN	TYP	MAX	UNIT
Supply voltage range, VDD	4.5	12	18	V
Operating junction temperature range	-40		140	°C
Input voltage, INA, INB	0		18	V

8.4 ELECTRICAL CHARACTERISTICS

VDD=12V, T_J=-40°C to 140°C, 1μF capacitor from VDD to GND. Currents are positive into, negative out of the specified terminal.

SYMBOL	PARAMETER	TEST CONDITION	MIN	TYP	MAX	UNIT	
BIAS CURRENTS							
I _{DD(OFF)}	Startup current	VDD=3.4V	INA=VDD, INB=GND	35	47	80	μA
			INA = INB = GND	33	45	75	μA
			INA=VDD, INB=VDD	40	51	85	μA
I _{DD}	Startup current	VDD=12V	INA=VDD, INB=GND	270	310	430	μA
			INA = INB = GND	190	220	310	μA
			INA=VDD, INB=VDD	350	400	540	μA
UNDER VOLTAGE LOCKOUT (UVLO)							
V _{ON}	Supply start threshold	T _A = 25°C		4.3		V	
		T _A = -40°C to 150°C	3.9	4.3	4.5	V	
V _{OFF}	Minimum operating Voltage after supply start	T _A = -40°C to 150°C	3.45	4	4.45	V	
V _{DD,H}	Supply voltage hysteresis	T _A = 25°C		0.3		V	
INPUTS(INA,INB)							
V _{IN,H}	Input signal high threshold	Output high for INA/B pin			2.8	V	
V _{IN,L}	Input signal low threshold	Output low for INA/B pin	1.0			V	
R _{IN}	Input pull down resistor	VDD=12V,VIN=4V	150	235	310	kΩ	
SOURCE/SINK Current (OUTA,OUTB)							
I _{SRC/SNK} ⁽²⁾	Source/ Sink peak current	C _{LOAD} =0.22μF, F _{SW} = 1kHz		±5		A	
OUTPUTS (OUT)							
V _{OD} -V _{OH}	High output voltage	VDD = 12V, I _{OUT} =-10mA		30		mV	
		VDD = 4.5V, I _{OUT} =-10mA		35		mV	
V _{OL}	Low output voltage	VDD = 12V, I _{OUT} =10mA		5.05		mV	
		VDD = 4.5V, I _{OUT} =10mA		5.15		mV	
R _{OH}	Output pullup resistance	VDD = 12V, I _{OUT} =10mA		3	4.7	Ω	
		VDD = 4.5V, I _{OUT} =10mA		3.5		Ω	
R _{OL}	Output pulldown resistance	VDD = 12V, I _{OUT} =10mA		0.5	0.7	Ω	
		VDD = 4.5V, I _{OUT} =10mA		0.5		Ω	
SWITCHING CHARACTERISTICS							
T _R	Rise time ⁽¹⁾⁽²⁾	VDD = 12V, C _{LOAD} =1.8nF		7		ns	
		VDD = 4.5V, C _{LOAD} =1.8nF		15.5			
T _F	Fall time ⁽¹⁾⁽²⁾	VDD = 12V, C _{LOAD} =1.8nF		6		ns	
		VDD = 4.5V, C _{LOAD} =1.8nF		5.5			
t _{D1}	INA to output propagation delay ⁽¹⁾⁽²⁾	VDD=12V, 5V input pulse C _{LOAD} =1.8nF		13		ns	
		VDD=4.5V, 5V input pulse C _{LOAD} =1.8nF		16			
t _{D2}	INB to output propagation delay ⁽¹⁾⁽²⁾	VDD=12V, 5V input pulse C _{LOAD} =1.8nF		13		ns	
		VDD=4.5V, 5V input pulse C _{LOAD} =1.8nF		16			

(1) See timing diagrams in Figure 1, Figure 2.

(2) This parameter is ensured by design and/or characterization and is not tested in production.

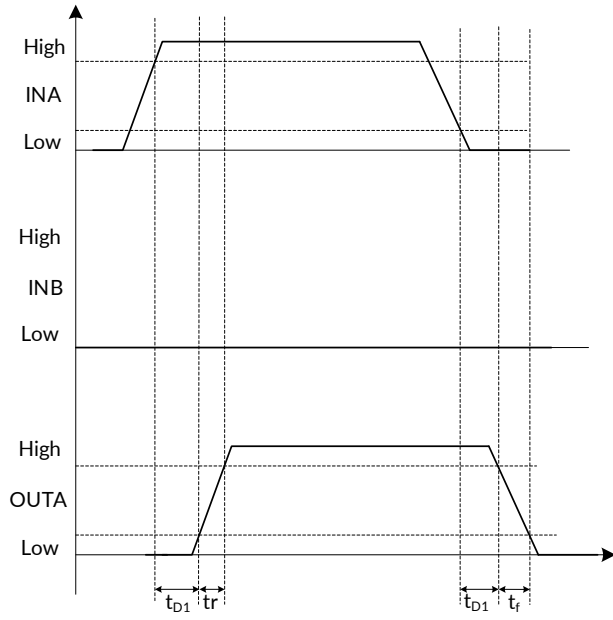

**Figure 1. PWM Input to INA pin
(INB pin tied to GND)**

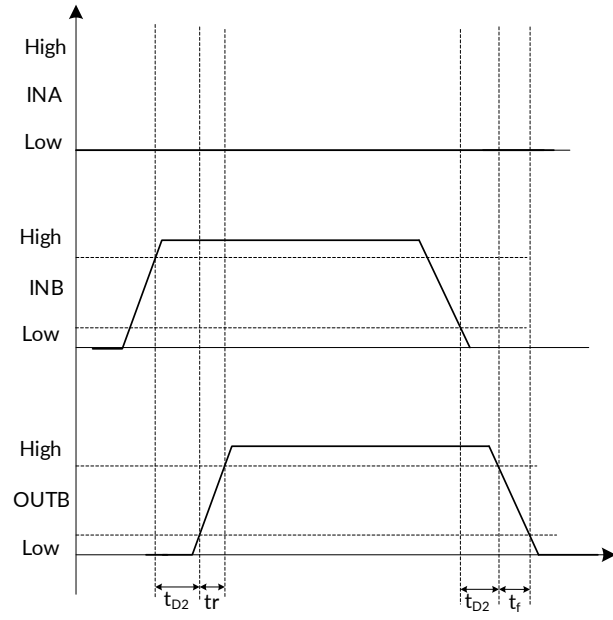

**Figure 2. PWM Input to INB pin
(INA pin tied to GND)**

8.5 TYPICAL PERFORMANCE CHARACTERISTICS

NOTE: The graphs and tables provided following this note are a statistical summary based on a limited number of samples and are provided for informational purposes only.

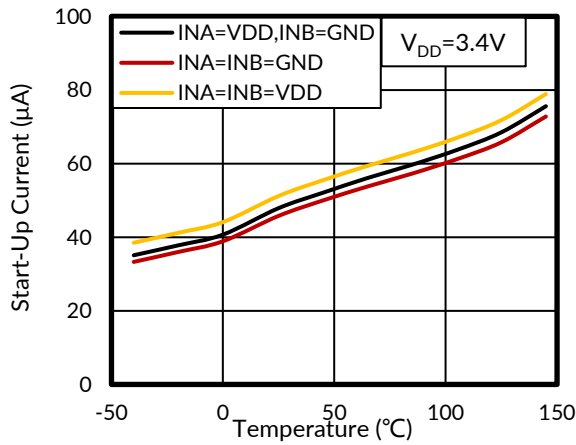

Figure 3. Start-Up Current vs Temperature

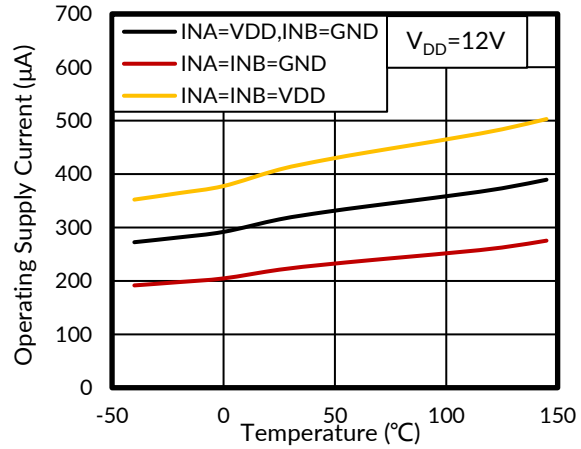

Figure 4. Supply Current vs Temperature (Output in DCON/OFF Condition)

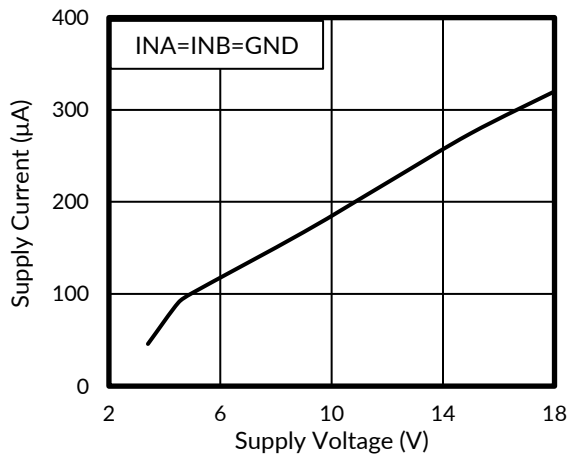

Figure 5. Supply Current vs Supply Voltage

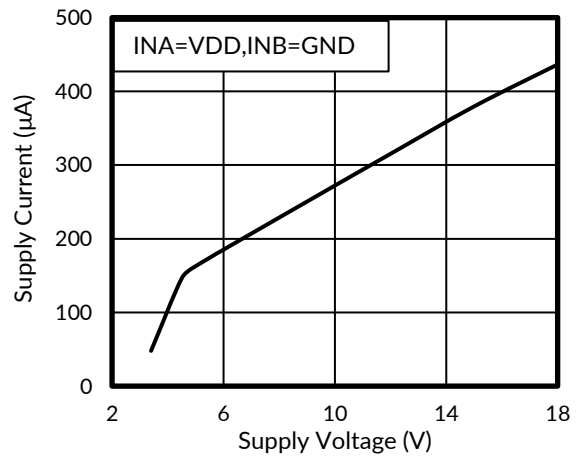

Figure 6. Supply Current vs Supply Voltage

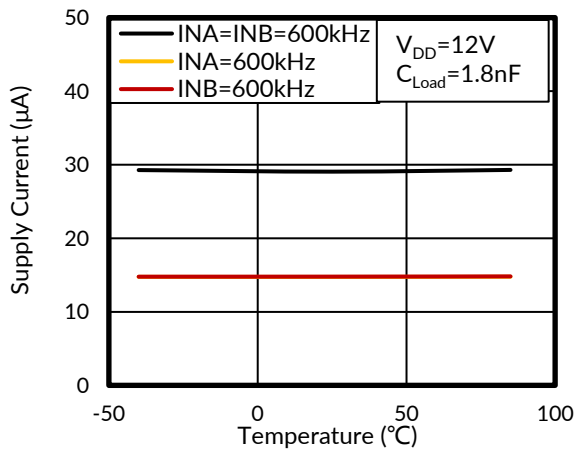

Figure 7. Operating Supply Current vs Temperature (Output Switching)

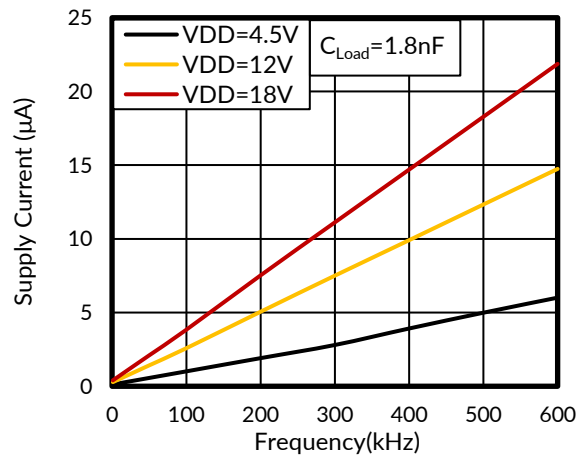

Figure 8. Single Channel Operating Supply Current vs Frequency

TYPICAL PERFORMANCE CHARACTERISTICS

NOTE: The graphs and tables provided following this note are a statistical summary based on a limited number of samples and are provided for informational purposes only.

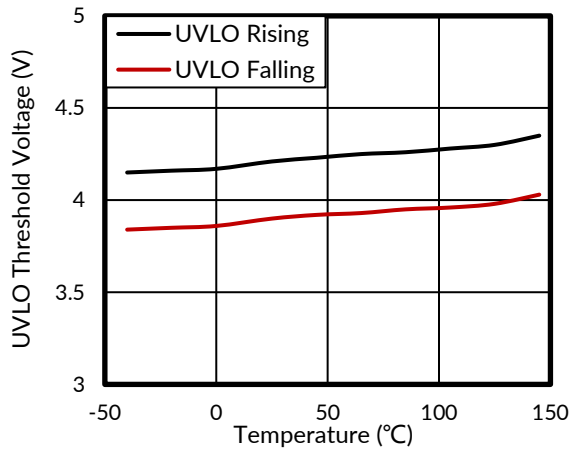

Figure 9. UVLO Threshold Voltage vs Temperature

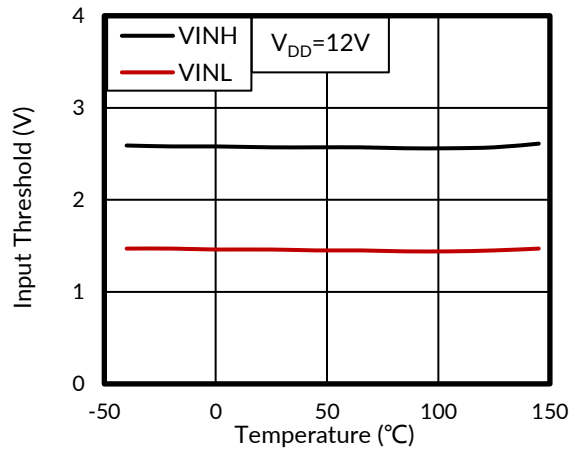

Figure 10. Input Threshold vs Temperature

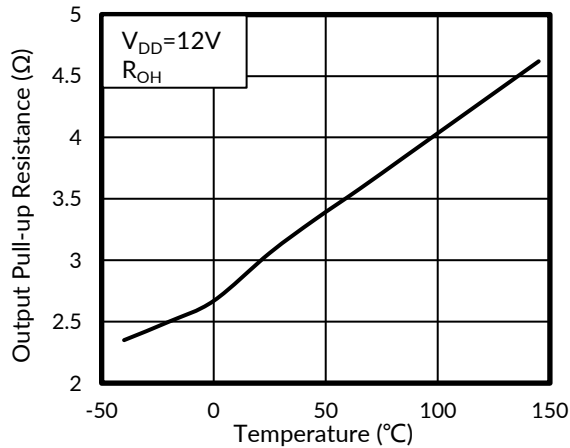

Figure 11. Output Pullup Resistance vs Temperature

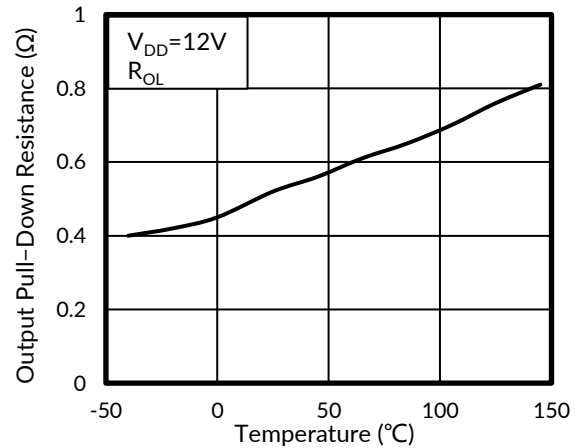

Figure 12. Output Pulldown Resistance vs Temperature

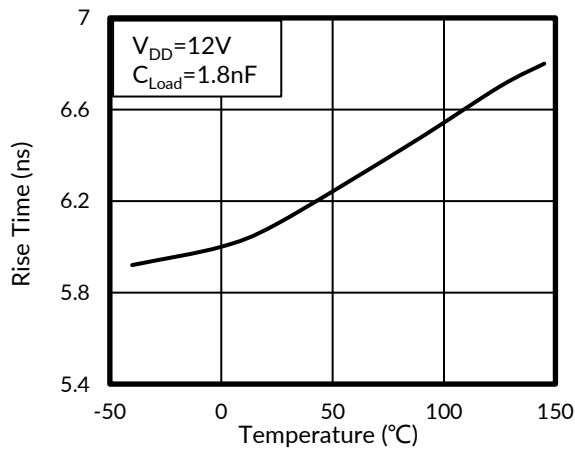

Figure 13. Rise Time vs Temperature

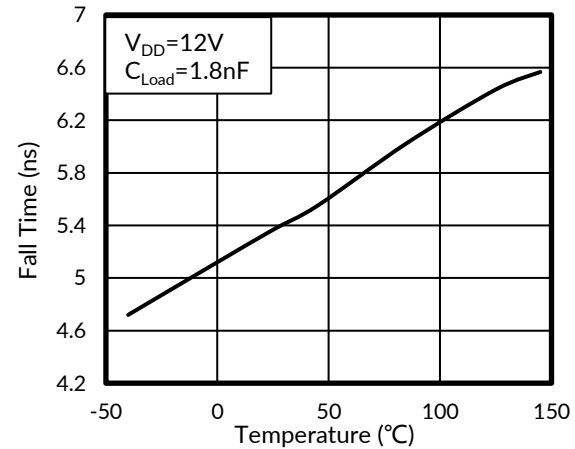

Figure 14. Fall Time vs Temperature

TYPICAL PERFORMANCE CHARACTERISTICS

NOTE: The graphs and tables provided following this note are a statistical summary based on a limited number of samples and are provided for informational purposes only.

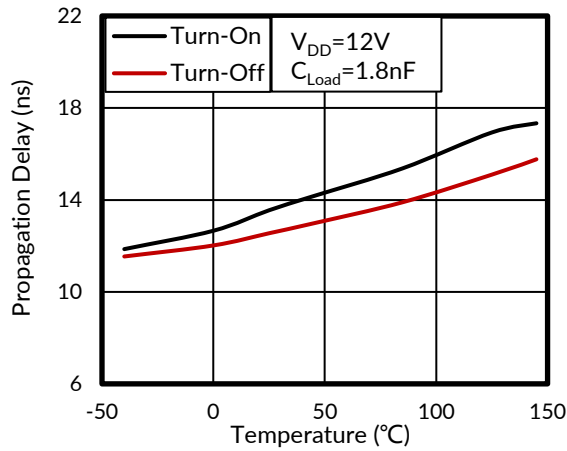

Figure 15. Input to Output Propagation Delay vs Temperature

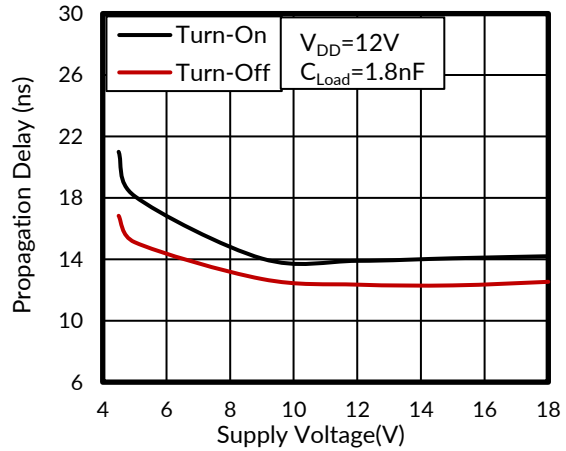

Figure 16. Propagation Delay vs Supply Voltage

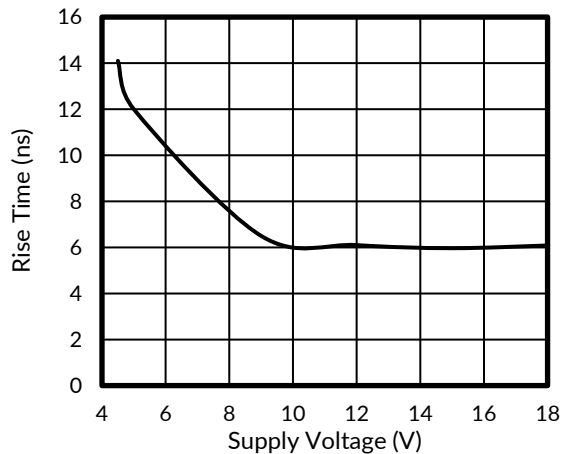

Figure 17. Rise Time vs Supply Voltage

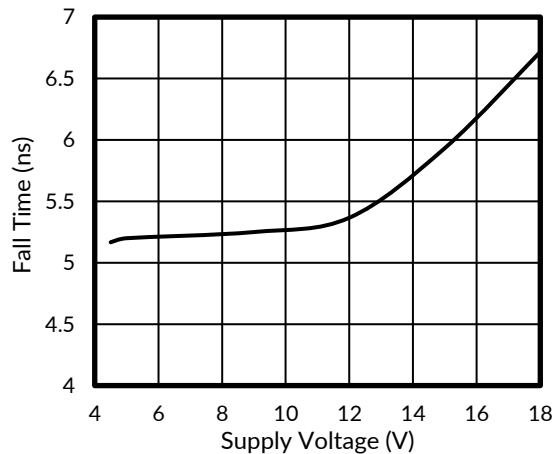

Figure 18. Fall Time vs Supply Voltage

9 Detailed Description

9.1 Overview

The RS8802 dual-channel, high-speed, low-side gate driver device is capable of effectively driving MOSFET and IGBT power switches. Using a design that inherently minimizes shoot-through current, the RS8802 is capable of sourcing and sinking high peak-current pulses into capacitive loads offering rail-to-rail drive capability and extremely small propagation delay typically 13ns.

The RS8802 device is capable of handling -4V at input.

The RS8802 provides 5A source and sink peak-drive current capability at VDD = 12V.

The RS8802 is designed to operate over a wide VDD range of 4.5V to 18V and wide temperature range of -40°C to 140°C.

9.2 Functional Block Diagram

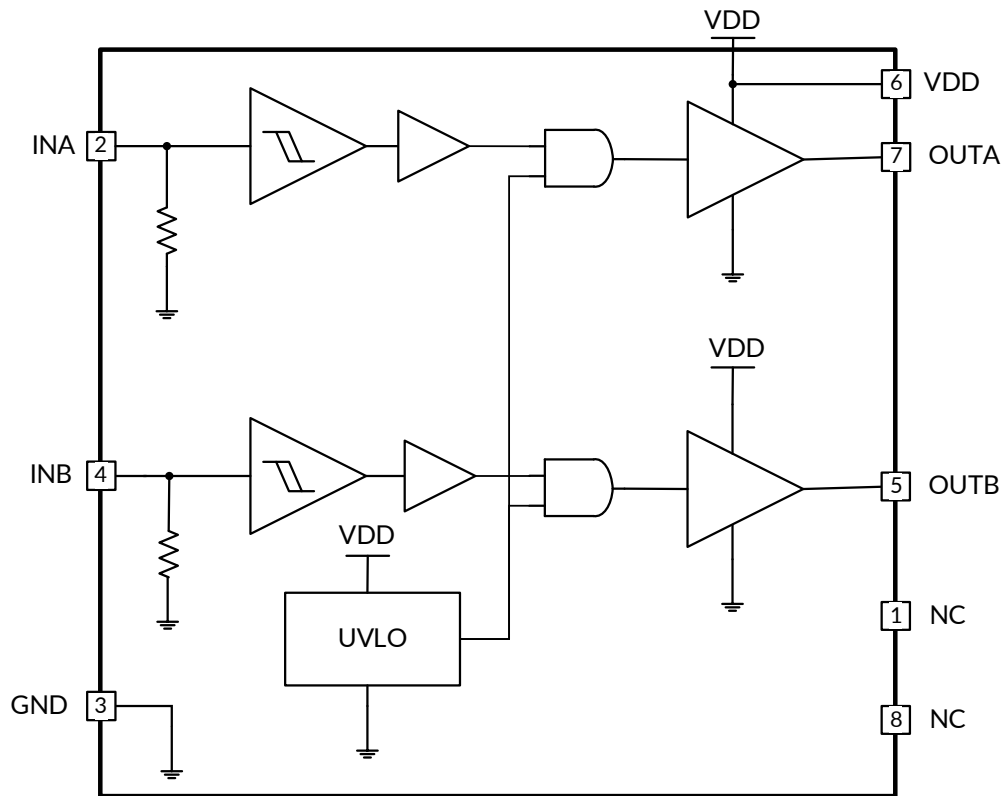

9.3 V_{DD} and Undervoltage Lockout

The RS8802 has internal Undervoltage Lockout (UVLO) protection feature on the V_{DD}-pin supply-circuit blocks. Whenever the driver is in UVLO condition (for example when V_{DD} voltage is less than V_{ON} during power up and when V_{DD} voltage is less than V_{OFF} during power down), this circuit holds all outputs LOW, regardless of the status of the inputs. The UVLO is typically 4.3V with 300mV typical hysteresis.

Because the driver draws current from the V_{DD} pin to bias all internal circuits, for the best high-speed circuit performance, two V_{DD} bypass capacitors are recommended to prevent noise problems. The use of surface mount components is highly recommended. A 0.1μF ceramic capacitor should be located as close as possible to the V_{DD} to GND pins of the gate driver. In addition, a larger capacitor (such as 1μF) with relatively low ESR should be connected in parallel and close proximity, in order to help deliver the high-current peaks required by the load. The parallel combination of capacitors should present a low impedance characteristic for the expected current levels and switching frequencies in the application.

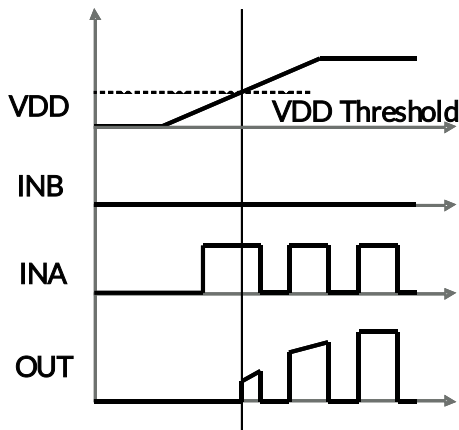

Figure 19. Power-Up (Non-Inverting Drive)

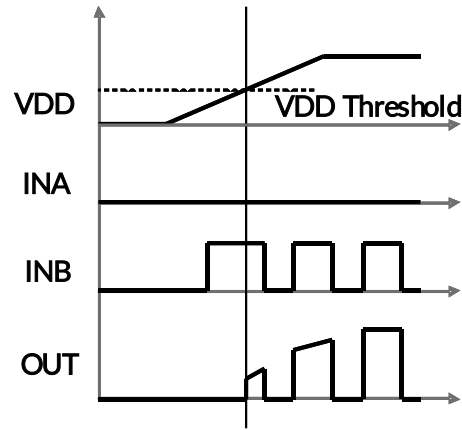

Figure 20. Power-Up (Inverting Drive)

9.4 Device Functional Modes

In the normal mode the output state is dependent on states of the INA and INB pins. Table 1 below lists the output states for different input pin combinations.

Table 1. Device Logic Table

INA PIN	INB PIN	OUTA PIN	OUTB PIN
L	L	L	L
L	H	L	H
H	L	H	L
H	H	H	H
Any	Any	L	L
x ⁽¹⁾	x ⁽¹⁾	L	L

(1) x = Floating Condition.

10 Power Supply Recommendations

The bias supply voltage range for which the RS8802 device is rated to operate is from 4.5V to 18V. The lower end of this range is governed by the internal UVLO protection feature on the VDD pin supply circuit blocks. Whenever the driver is in UVLO condition when the V_{DD} pin voltage is below the V(ON) supply start threshold, this feature holds the output low, regardless of the status of the inputs. The upper end of this range is driven by the 22V absolute maximum voltage rating of the VDD pin of the device (which is a stress rating). Keeping a 2V margin to allow for transient voltage spikes, the maximum recommended voltage for the VDD pin is 18V.

11 Layout

The following circuit layout guidelines are strongly recommended when designing with these high-speed drivers.

- Locate the driver device as close as possible to the power device in order to minimize the length of high current traces between the output pins and the gate of the power device.
- Locate the VDD bypass capacitors between VDD and GND as close as possible to the driver with minimal trace length to improve the noise filtering. These capacitors support high-peak current being drawn from VDD during turn on of power MOSFET. The use of low inductance SMD components such as chip resistors and chip capacitors is highly recommended.

12 PACKAGE OUTLINE DIMENSIONS

SOP8⁽³⁾

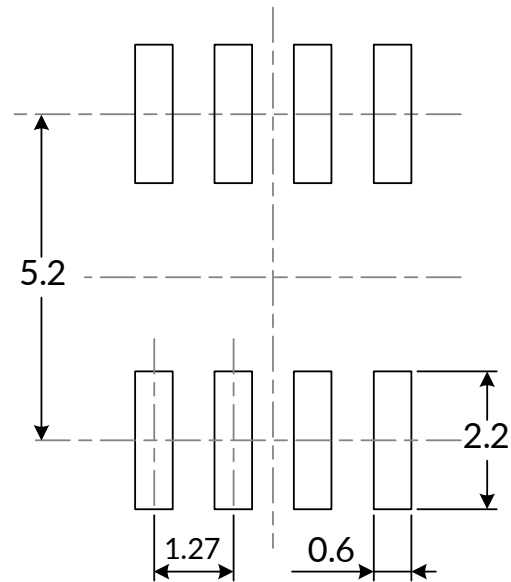
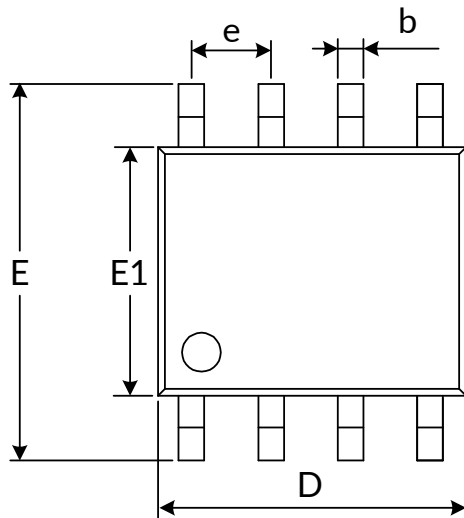

RECOMMENDED LAND PATTERN (Unit: mm)

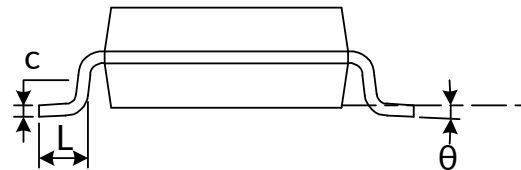
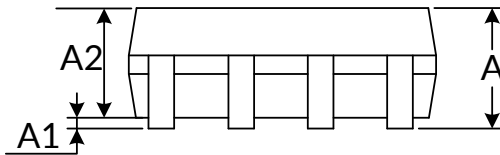

Symbol	Dimensions In Millimeters		Dimensions In Inches	
	Min	Max	Min	Max
A ⁽¹⁾	1.350	1.750	0.053	0.069
A1	0.100	0.250	0.004	0.010
A2	1.350	1.550	0.053	0.061
b	0.330	0.510	0.013	0.020
c	0.170	0.250	0.007	0.010
D ⁽¹⁾	4.800	5.000	0.189	0.197
e	1.270(BSC) ⁽²⁾		0.050(BSC) ⁽²⁾	
E	5.800	6.200	0.228	0.244
E1 ⁽¹⁾	3.800	4.000	0.150	0.157
L	0.400	1.270	0.016	0.050
θ	0°	8°	0°	8°

NOTE:

1. Plastic or metal protrusions of 0.15mm maximum per side are not included.
2. BSC (Basic Spacing between Centers), "Basic" spacing is nominal.
3. This drawing is subject to change without notice.

13 TAPE AND REEL INFORMATION

REEL DIMENSIONS

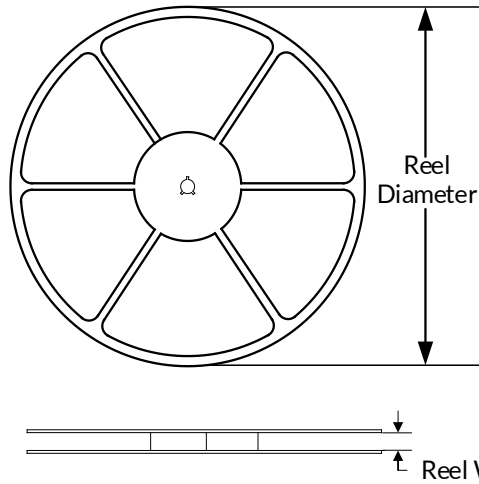

TAPE DIMENSION

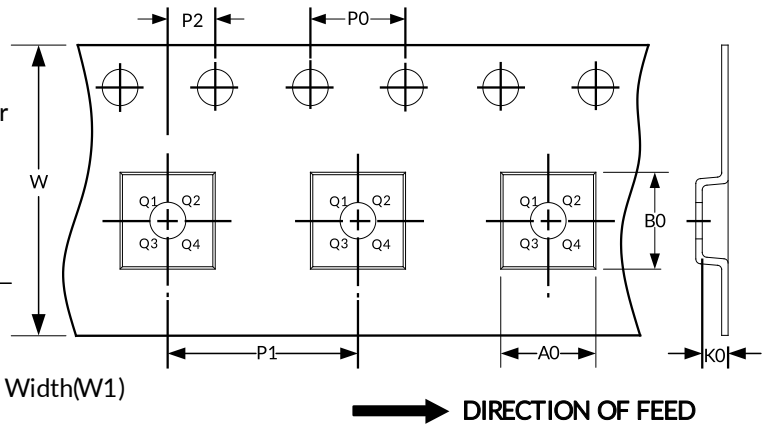

NOTE: The picture is only for reference. Please make the object as the standard.

KEY PARAMETER LIST OF TAPE AND REEL

Package Type	Reel Diameter	Reel Width(mm)	A0 (mm)	B0 (mm)	K0 (mm)	P0 (mm)	P1 (mm)	P2 (mm)	W (mm)	Pin1 Quadrant
SOP8	13"	12.4	6.40	5.40	2.10	4.0	8.0	2.0	12.0	Q1

NOTE:

1. All dimensions are nominal.
2. Plastic or metal protrusions of 0.15mm maximum per side are not included.

IMPORTANT NOTICE AND DISCLAIMER

Jiangsu Runic Technology Co., Ltd. will accurately and reliably provide technical and reliability data (including data sheets), design resources (including reference designs), application or other design advice, WEB tools, safety information and other resources, without warranty of any defect, and will not make any express or implied warranty, including but not limited to the warranty of merchantability Implied warranty that it is suitable for a specific purpose or does not infringe the intellectual property rights of any third party.

These resources are intended for skilled developers designing with Runic products You will be solely responsible for: (1) Selecting the appropriate products for your application; (2) Designing, validating and testing your application; (3) Ensuring your application meets applicable standards and any other safety, security or other requirements; (4) Runic and the Runic logo are registered trademarks of Runic Incorporated. All trademarks are the property of their respective owners; (5) For change details, review the revision history included in any revised document. The resources are subject to change without notice. Our company will not be liable for the use of this product and the infringement of patents or third-party intellectual property rights due to its use.