

Wide-Bandwidth 4-Channel SPST Analog Switch

1 FEATURES

- **Wide Bandwidth: 300MHz**
- **Single Supply Operation +1.8V to +5.5V**
- **Low ON Resistance, 4.5Ω(TYP)**
- **High Speed: Typical 30ns**
- **Rail-to-Rail Operation**
- **TTL/CMOS Compatible**
- **Operating Temperature Range:
-40°C to +125°C**
- **PACKAGES: SSOP16, TSSOP14**

2 APPLICATIONS

- **Game Consoles**
- **Audio and Video Switching**
- **Wired networking**
- **Personal Video Recorders**
- **Supports defense, aerospace and medical applications**
- **Desktop Video Editors**
- **Hard Disk Recorders**

3 DESCRIPTION

The RS2268 is a CMOS analog IC configured as a quad, bidirectional, single-pole/single-throw (SPST) switches. This CMOS device can operate from 1.8 V to 5.5 V.

The RS2268 device can handle both analog and digital signals. It features high-bandwidth (300MHz) and low on-resistance (4.5Ω TYP). Each switch is disabled when the associated output-enable (IN) input is low.

The RS2268 is available in Green SSOP16, TSSOP14 packages. It operates over an ambient temperature range of -40°C to +125°C.

Device Information ⁽¹⁾

PART NUMBER	PACKAGE	BODY SIZE (NOM)
RS2268	TSSOP14	5.00mm×4.40mm
	SSOP16	4.90mm×3.90mm

(1) For all available packages, see the orderable addendum at the end of the data sheet.

Table of Contents

1 FEATURES	1
2 APPLICATIONS	1
3 DESCRIPTION	1
4 Revision History	3
5 PACKAGE/ORDERING INFORMATION	4
6 Pin Configuration and Function	5
7 PIN CONFIGURATIONS	6
8 SPECIFICATIONS	7
8.1 Absolute Maximum Ratings ⁽¹⁾	7
8.2 ESD Ratings	7
8.3 Recommended Operating Conditions	7
8.4 Thermal Information	7
8.5 ELECTRICAL CHARACTERISTICS	8
8.6 TYPICAL CHARACTERISTICS	10
9 Parameter Measurement Information	11
10 PACKAGE OUTLINE DIMENSIONS	14
11 TAPE AND REEL INFORMATION	16

4 Revision History

Note: Page numbers for previous revisions may differ from page numbers in the current version.

Version	Change Date	Change Item
A.0	2022/03/10	Initial version completed
A.1	2022/06/20	Official version completed
A.1.1	2024/03/08	Modify packaging naming

5 PACKAGE/ORDERING INFORMATION

PRODUCT	ORDERING NUMBER	TEMPERATURE RANGE	PACKAGE LEAD	PACKAGE MARKING ⁽¹⁾	PACKAGE OPTION
RS2268	RS2268XSS16	-40°C~+125°C	SSOP16	RS2268	Tape and Reel,4000
	RS2268XQ	-40°C~+125°C	TSSOP14	RS2268	Tape and Reel,4000

NOTE:

- (1) There may be additional marking, which relates to the lot trace code information (data code and vendor code), the logo or the environmental category on the device.

6 Pin Configuration and Function

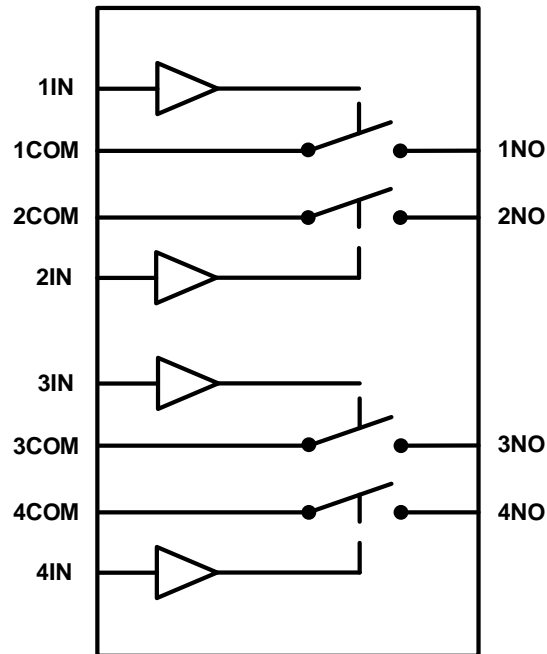

FUNCTION TABLE

INPUTS		FUNCTION
IN		
L		Disconnect
H		COM Port = NO Port

NOTE: Input and output pins are identical and inter-changeable. Either may be considered an input or output; signals pass equally well in either direction.

7 PIN CONFIGURATIONS

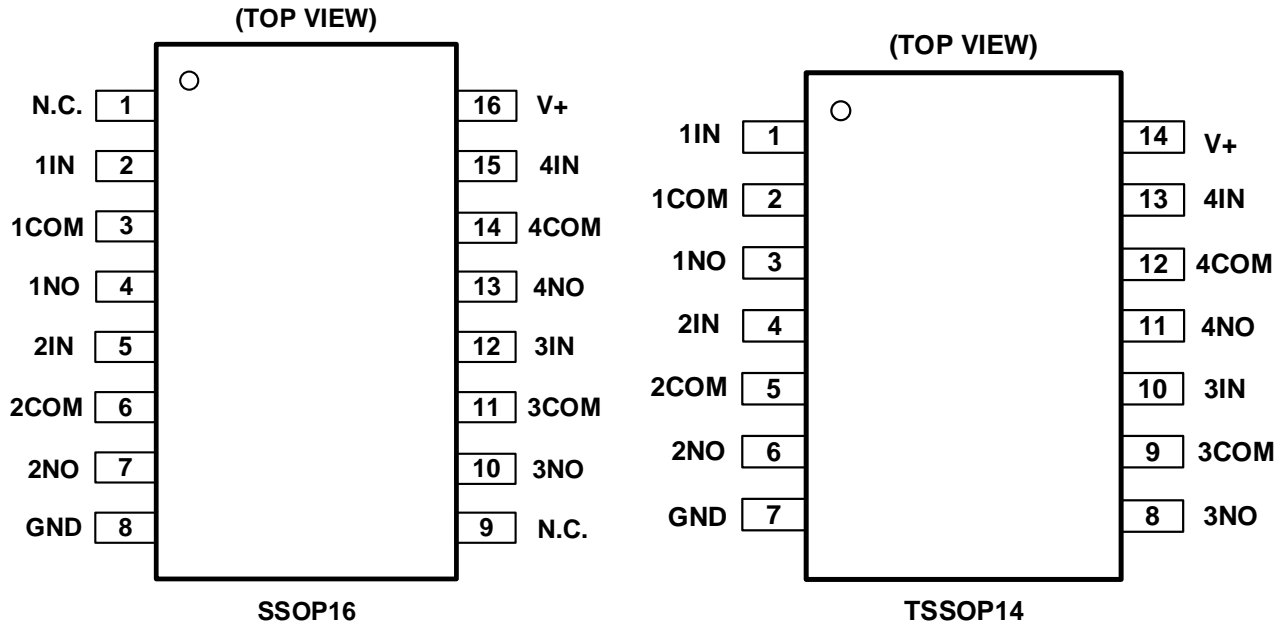

NOTE: N.C.= No internet connection

PIN DESCRIPTION

NAME	PIN		FUNCTION
	SSOP16	TSSOP14	
N.C.	1	/	No internet connection
1IN	2	1	Channel 1 Switch-Enable Input.
1COM	3	2	Channel 1, input or output
1NO	4	3	Channel 1, input or output
2IN	5	4	Channel 2 Switch-Enable Input.
2COM	6	5	Channel 2, input or output
2NO	7	6	Channel 2, input or output
GND	8	7	Ground.
N.C.	9	/	No internet connection
3NO	10	8	Channel 3, input or output
3COM	11	9	Channel 3, input or output
3IN	12	10	Channel 3 Switch-Enable Input.
4NO	13	11	Channel 4, input or output
4COM	14	12	Channel 4, input or output
4IN	15	13	Channel 4 Switch-Enable Input.
V+	16	14	Power Supply.

8 SPECIFICATIONS

8.1 Absolute Maximum Ratings ⁽¹⁾

Over operating free-air temperature range (unless otherwise noted) ⁽¹⁾

SYMBOL	PARAMETER	MIN	MAX	UNIT
V+	Supply Voltage	-0.3	6	V
V _{IN}	Input Voltage (All inputs)	-0.3	6	
	Continuous Current	-300	+300	mA
I _{PEAK}	Peak Current	-500	+500	mA
T _J	Junction temperature	-40	150	°C
T _{stg}	Storage temperature	-65	+150	°C

(1) Stresses above these ratings may cause permanent damage. Exposure to absolute maximum conditions for extended periods may degrade device reliability. These are stress ratings only, and functional operation of the device at these or any other conditions beyond those specified is not implied.

8.2 ESD Ratings

		VALUE	UNIT	
V _(ESD)	Electrostatic discharge	Human-body model (HBM)	±1000	V
		Machine Model (MM)	±100	V

8.3 Recommended Operating Conditions

Over operating free-air temperature range (unless otherwise noted)

SYMBOL	PARAMETER	MIN	MAX	UNIT
V+	Supply Voltage	1.8	5.5	V
T _A	Operating temperature	-40	+125	°C

8.4 Thermal Information

THERMAL METRIC		RS2268		UNIT
		16 PINS	14 PINS	
		SSOP16	TSSOP14	
R _{θJA}	Junction-to-ambient thermal resistance	118.7	119.5	°C/W
R _{θJC(top)}	Junction-to-case(top) thermal resistance	66.4	48.2	°C/W
R _{θJB}	Junction-to-board thermal resistance	62.2	61.2	°C/W
Ψ _{JT}	Junction-to-top characterization parameter	20.9	5.5	°C/W
Ψ _{JB}	Junction-to-board characterization parameter	61.7	60.6	°C/W
R _{θJC(bot)}	Junction-to-case(bottom) thermal resistance	N/A	NA	°C/W

8.5 ELECTRICAL CHARACTERISTICS

V+= +1.8V to +5.5 V, FULL= -40°C to +125°C, Typical values are at T_A = +25°C. (unless otherwise noted)

PARAMETER	SYMBOL	CONDITIONS	V+	T _A	MIN	TYP	MAX	UNIT
DC CHARACTERISTICS								
Analog Signal Range	V _{NO} , V _{COM}			FULL	0		V+	V
On-Resistance	R _{ON}	0 ≤ V _{NO} ≤ V+/2, I _{COM} = -10mA, Switch ON, See Figure 4	5V	+25°C		4.5	8	Ω
				FULL			8.5	Ω
			3.3V	+25°C		7	10	Ω
				FULL			10.5	Ω
On-Resistance Match Between Channels	ΔR _{ON}	0 ≤ V _{NO} ≤ V+/2, I _{COM} = -10mA, Switch ON, See Figure 4	5V	+25°C		0.15	0.3	Ω
				FULL			0.4	Ω
			3.3V	+25°C		0.15	0.3	Ω
				FULL			0.4	Ω
On-Resistance Flatness	R _{FLAT(ON)}	0 ≤ V _{NO} ≤ V+/2, I _{COM} = -10mA, Switch ON, See Figure 4	5V	+25°C		2	3	Ω
				FULL			3.3	Ω
			3.3V	+25°C		3	4	Ω
				FULL			4.3	Ω
Leakage Current Off state	I _{Leak(OFF)}	V _{NO} = 0.3V, V+/2, V _{COM} = V+/2, 0.3V See Figure 5	1.8~5.5V	FULL			1	μA
Leakage Current On state	I _{Leak(ON)}	V _{NO} = 0.3V, Open, V _{COM} = Open, 0.3V See Figure 6	1.8~5.5V	FULL			1	μA
DIGITAL CONTROL INPUTS ⁽¹⁾								
High-level control input Voltage	V _{INH}		5V	FULL	1.5			V
			3.3V	FULL	1.3			V
Low-level control input Voltage	V _{INL}		5V	FULL			0.6	V
			3.3V	FULL			0.5	V
Input Leakage Current	I _{IN}	V _{IN} = V _{IO} or 0	1.8~5.5V	FULL			1	μA

(1) All unused digital inputs of the device must be held at V_{IO} or GND to ensure proper device operation.

ELECTRICAL CHARACTERISTICS

V+ = +1.8V to +5.5 V, FULL= -40°C to +125°C, Typical values are at T_A = +25°C. (unless otherwise noted)

PARAMETER	SYMBOL	CONDITIONS	V+	T _A	MIN	TYP	MAX	UNITS	
DYNAMIC CHARACTERISTICS									
Turn-On Time	t _{ON}	V _{COM} = V+, R _L = 300Ω, C _L = 35pF, See Figure 8	5V	+25°C		30		ns	
			3.3V			40			
Turn-Off Time	t _{OFF}	V _{COM} = V+, R _L = 300Ω, C _L = 35pF, See Figure 8	5V	+25°C		25		ns	
			3.3V			30			
Off Isolation	O _{ISO}	R _L = 50Ω, Switch OFF, See Figure 10		f = 10MHz	+25°C		-52		dB
				f = 1MHz	+25°C		-71		dB
-3dB Bandwidth	BW	Switch ON, R _L =50Ω, See Figure 9		+25°C		300		MHz	
OFF Capacitance	C _{OFF}	V _{NO} =V+/2 or GND, Switch OFF See Figure 7		+25°C		5		pF	
ON Capacitance	C _{ON}	V _{NO} =V+/2 or GND, Switch ON See Figure 7		+25°C		15		pF	
POWER REQUIREMENTS									
Power Supply Range	V+			FULL	1.8		5.5	V	
Power Supply Current	I+	V _{IN} = GND or V+	5.5V	FULL			4	μA	

8.6 TYPICAL CHARACTERISTICS

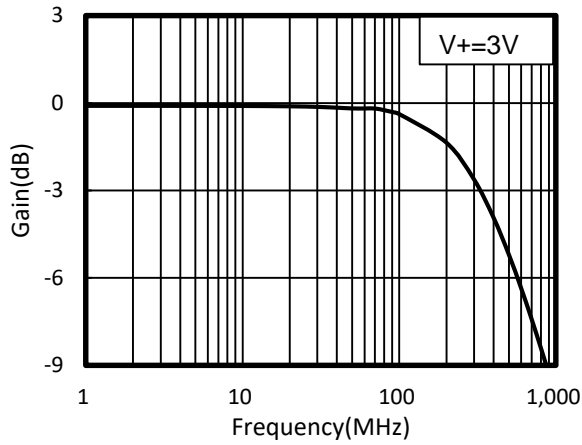

Figure 1. Bandwidth vs Frequency

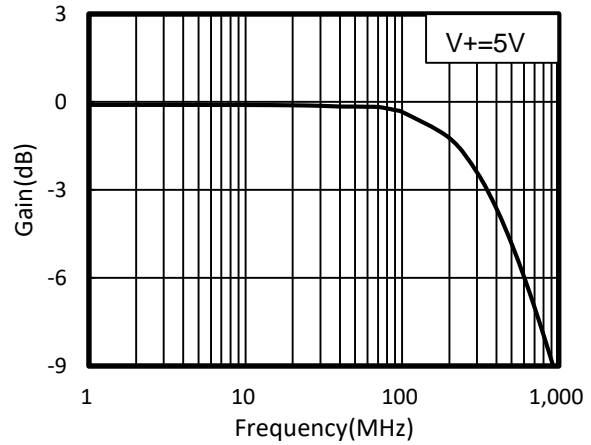

Figure 2. Bandwidth vs Frequency

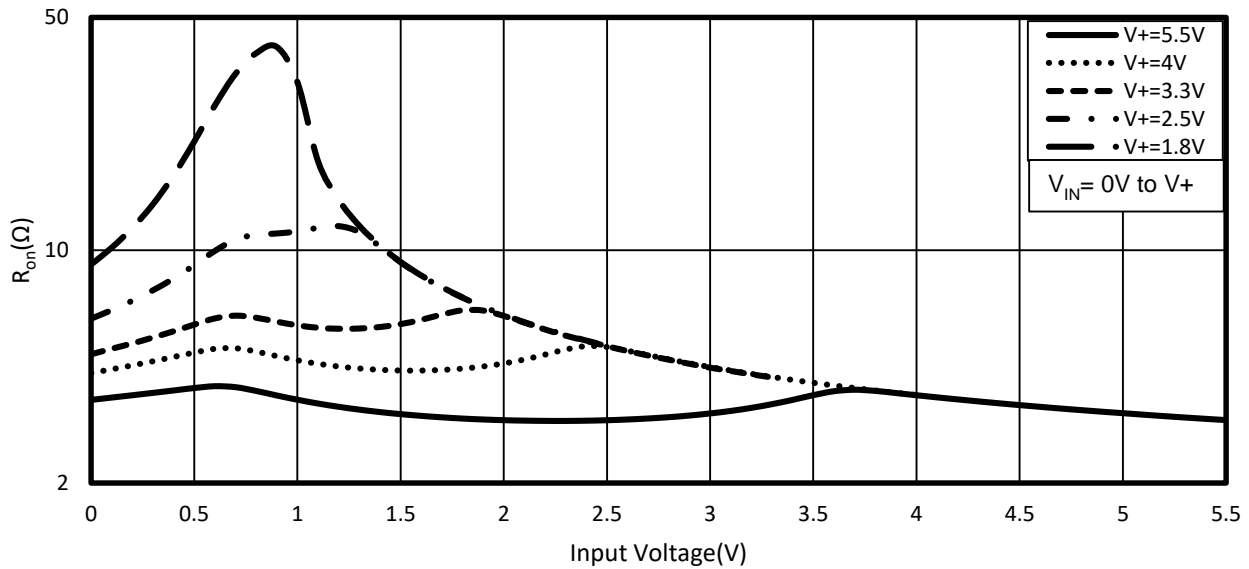

Figure 3. Typical Ron as a Function of Input Voltage

9 Parameter Measurement Information

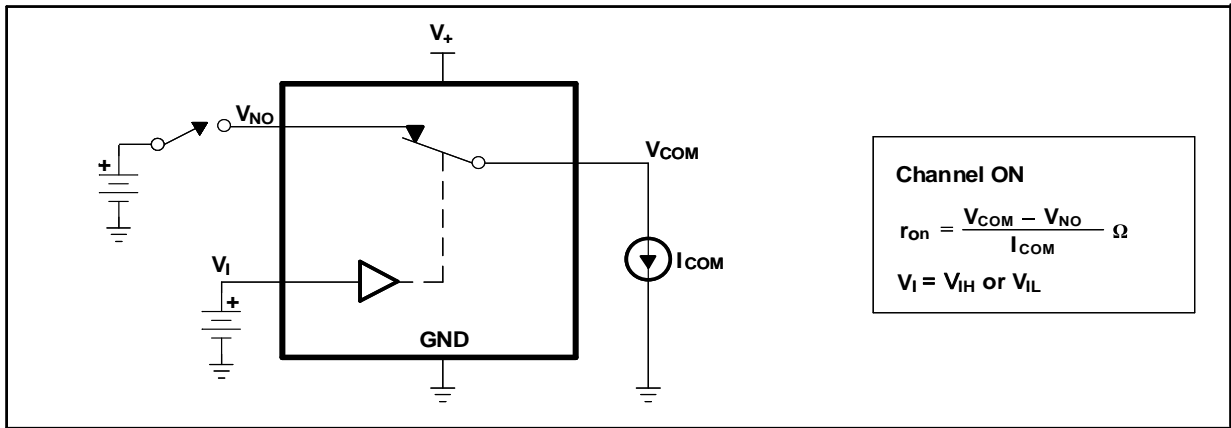

Figure 4. ON-State Resistance

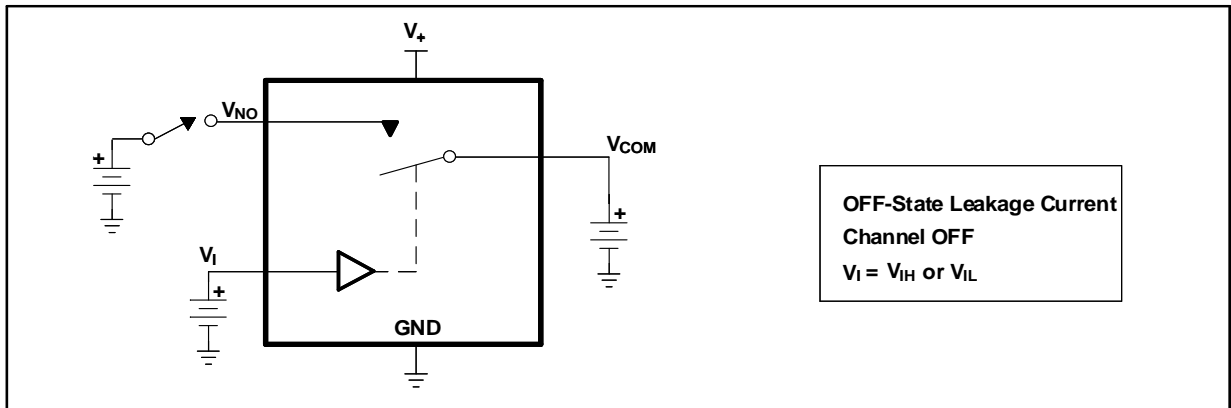

Figure 5. OFF-State Leakage Current

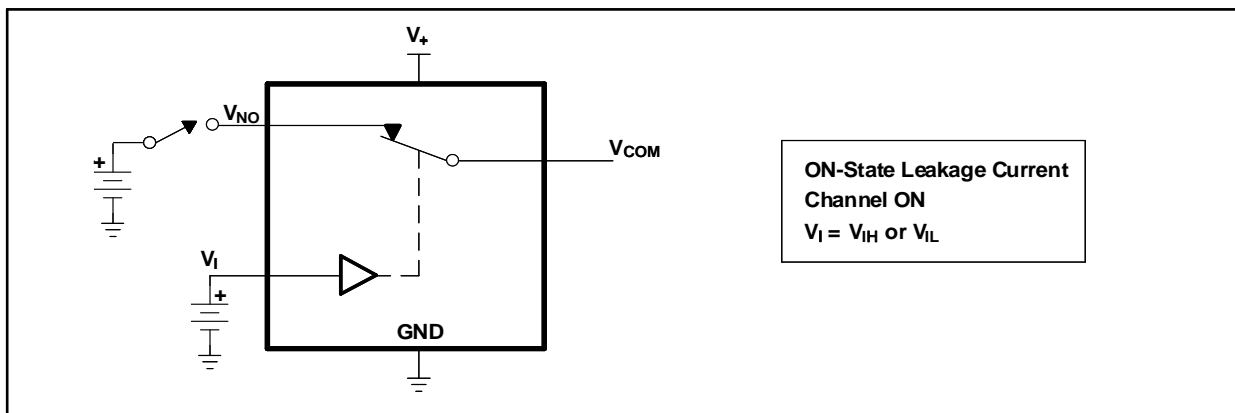

Figure 6. ON-State Leakage Current

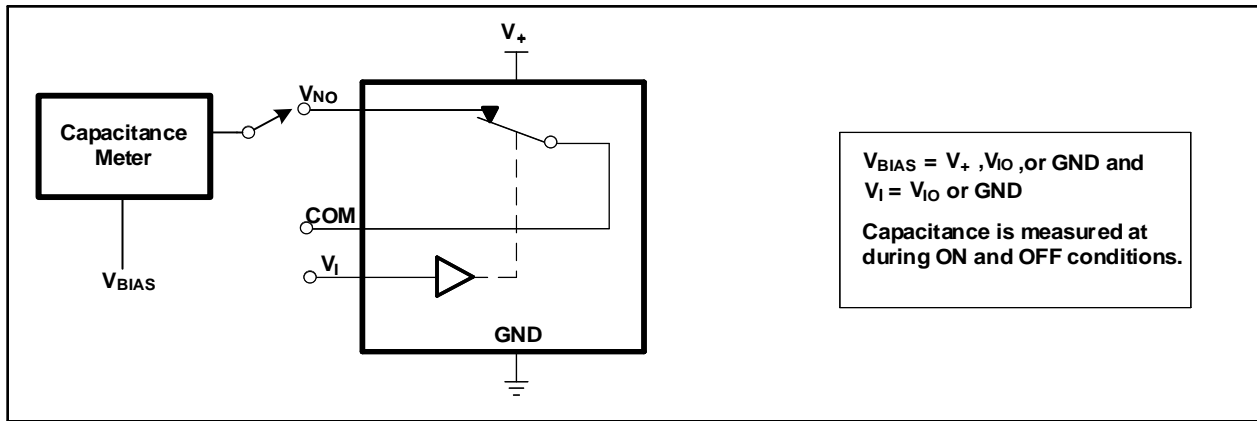

Figure 7. Capacitance C_{IN} or C_{OFF}

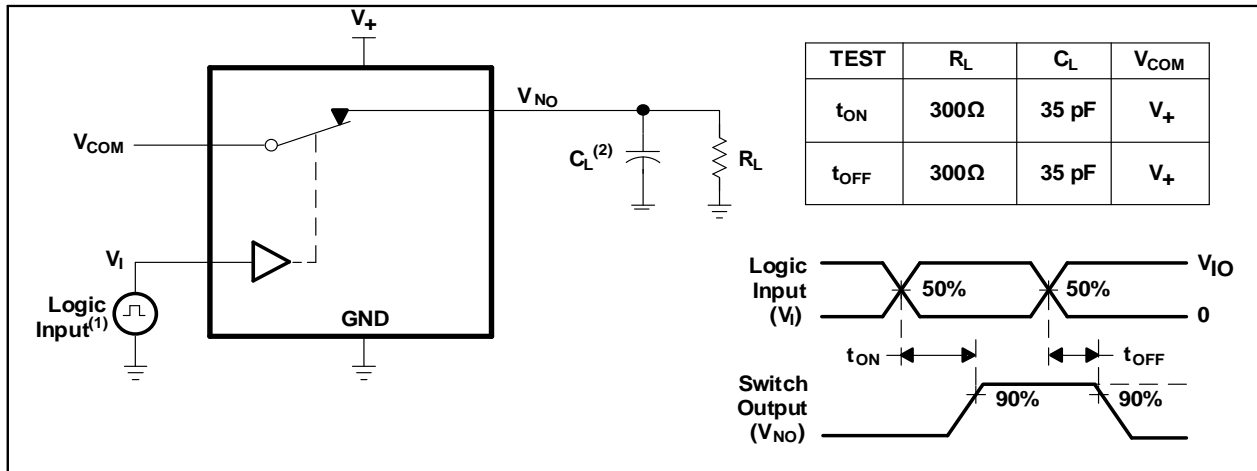

Figure 8. Turn-On (t_{ON}) and Turn-Off Time (t_{OFF})

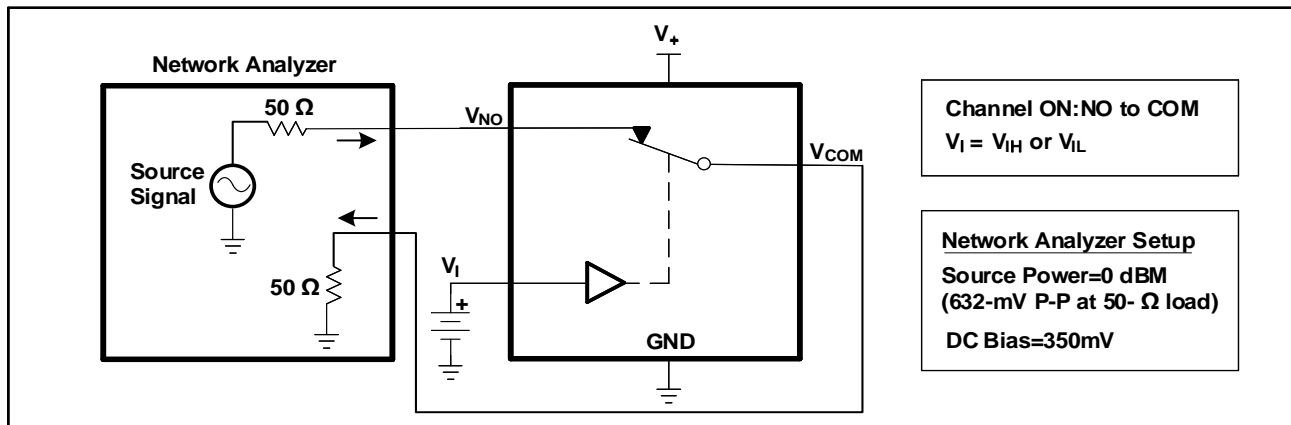

Figure 9. Bandwidth (BW)

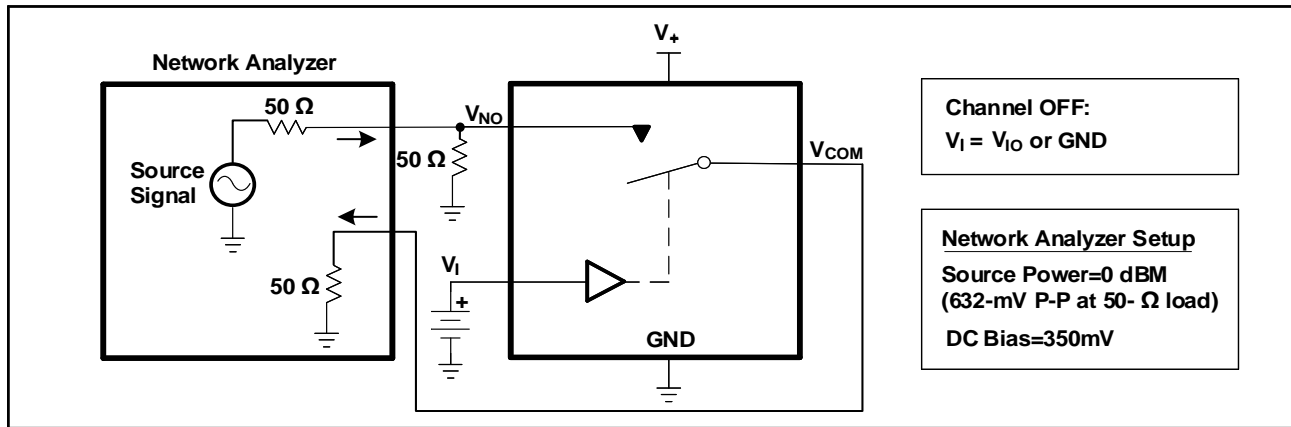
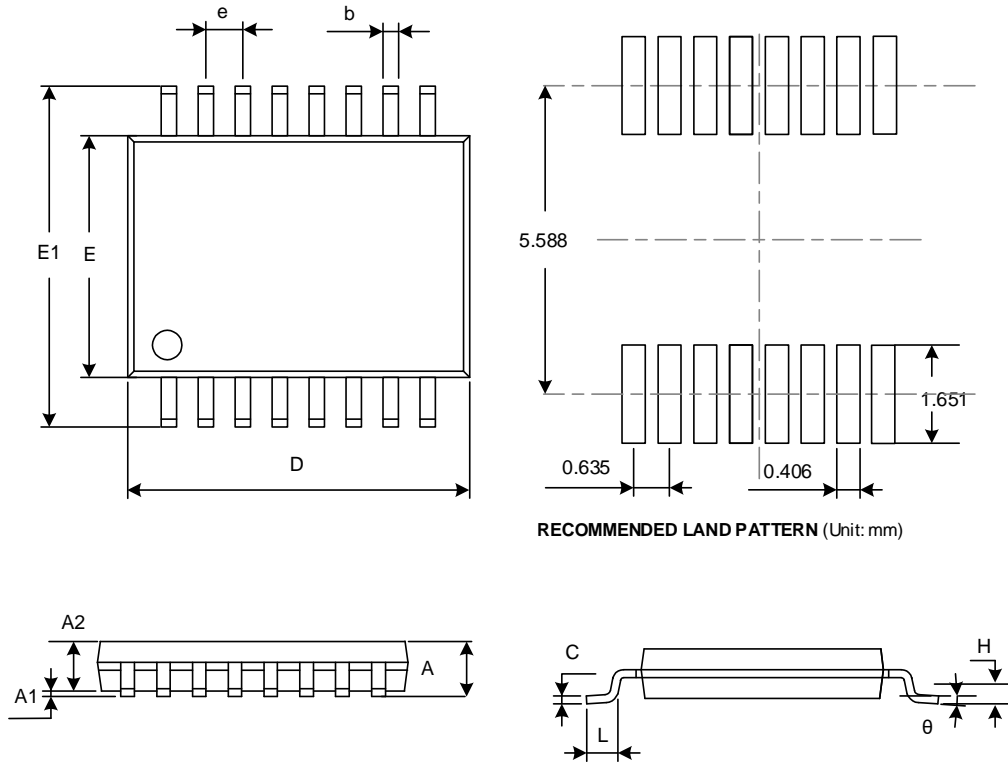

Figure 10. OFF Isolation (O_{iso})

10 PACKAGE OUTLINE DIMENSIONS

SSOP16



RECOMMENDED LAND PATTERN (Unit: mm)

Symbol	Dimensions In Millimeters		Dimensions In Inches	
	Min	Max	Min	Max
A	1.350	1.750	0.053	0.069
A1	0.100	0.250	0.004	0.010
A2	1.350	1.550	0.053	0.061
b	0.200	0.300	0.008	0.012
c	0.170	0.250	0.007	0.010
D	4.700	5.100	0.185	0.200
E	3.800	4.000	0.150	0.157
E1	5.800	6.200	0.228	0.244
e	0.635(BSC)		0.025(BSC)	
L	0.400	1.270	0.016	0.050
θ	0°	8°	0°	8°

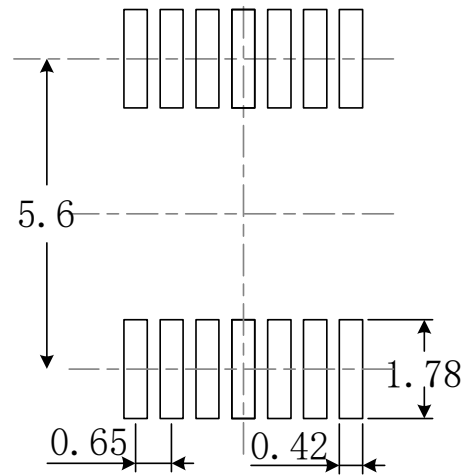
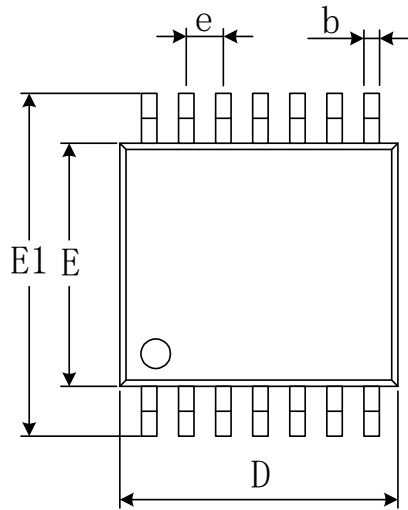
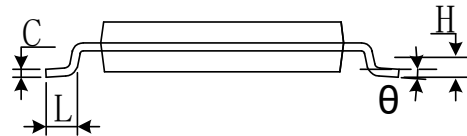
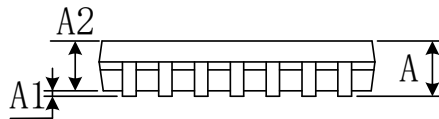
TSSOP14

RECOMMENDED LAND PATTERN (Unit: mm)

Symbol	Dimensions In Millimeters		Dimensions In Inches	
	Min	Max	Min	Max
A		1.200		0.047
A1	0.050	0.150	0.002	0.006
A2	0.800	1.050	0.031	0.041
b	0.190	0.300	0.007	0.012
c	0.090	0.200	0.004	0.008
D	4.860	5.100	0.191	0.201
E	4.300	4.500	0.169	0.177
E1	6.200	6.600	0.244	0.260
e	0.650(BSC)		0.026(BSC)	
L	0.500	0.700	0.02	0.028
H	0.25TYP		0.01TYP	
θ	1°	7°	1°	7°

11 TAPE AND REEL INFORMATION

REEL DIMENSIONS

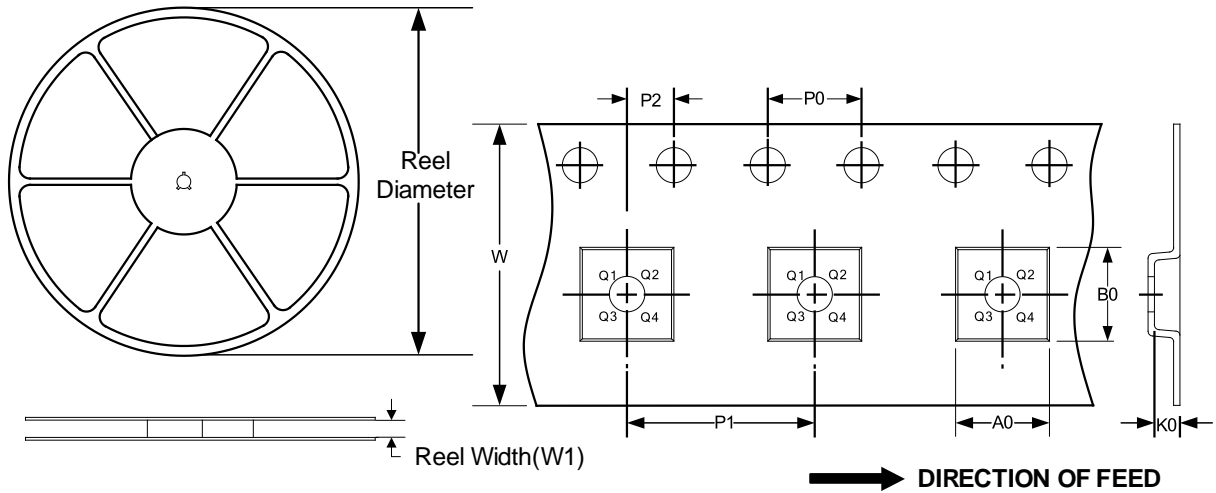
TAPE DIMENSION



NOTE: The picture is only for reference. Please make the object as the standard.

KEY PARAMETER LIST OF TAPE AND REEL

Package Type	Reel Diameter	Reel Width(mm)	A0 (mm)	B0 (mm)	K0 (mm)	P0 (mm)	P1 (mm)	P2 (mm)	W (mm)	Pin1 Quadrant
TSSOP14	13"	12.4	6.95	5.60	1.20	4.0	8.0	2.0	14.0	Q1
SSOP16	13"	12.4	8.30	6.70	2.10	4.0	8.0	2.0	12.0	Q1