

Ultra-Low ON-Resistance, Low Voltage, Dual, SPDT Analog Switch

FEATURES

- **-3dB Bandwidth: 110MHz**
- **High Speed, Typically 50ns**
- **Supply Range: +1.8V to +5.5V**
- **Low ON-State Resistance, 0.6Ω(TYP)**
- **Break-Before-Make Switching**
- **Rail-to-Rail Operation**
- **TTL/CMOS Compatible**
- **Extended Industrial Temperature Range: -40°C to +125°C**
- **Micro SIZE PACKAGES: XQFN1.4X1.8-10**

DESCRIPTION

The RS2323 is a dual, low on-resistance, single-pole double-throw (SPDT) analog switch that is designed to operate from 1.8 V to 5.5 V.

The RS2323 device can handle both analog and digital signals. It features fast switching speeds (50ns) and low on-resistance (0.6Ω TYP).

Applications include signal gating, chopping, modulation or demodulation (modem), and signal multiplexing for analog-to-digital and digital-to-analog conversion systems.

APPLICATIONS

- **Wearable Devices**
- **Battery-Operated Equipment**
- **Signal Gating, Chopping, Modulation or Demodulation (Modem)**
- **Portable Computing**
- **Cell Phones**

Device Information ⁽¹⁾

PART NUMBER	PACKAGE	BODY SIZE (NOM)
RS2323	XQFN1.4X1.8-10	1.80mm×1.40mm

(1) For all available packages, see the orderable addendum at the end of the data sheet.

Functional Block Diagram

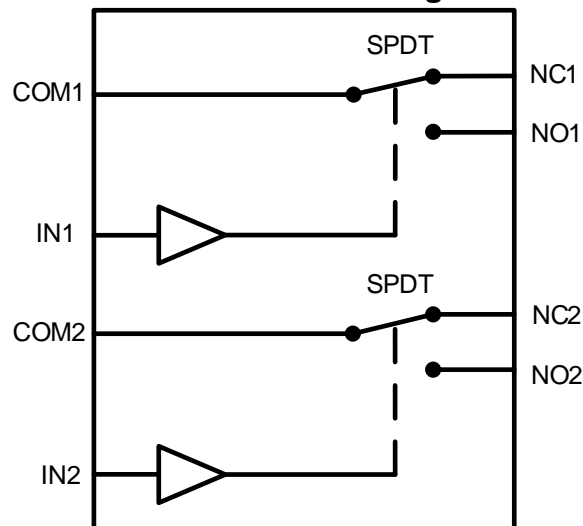

Revision History

Note: Page numbers for previous revisions may differ from page numbers in the current version.

VERSION	Change Date	Change Item
D.1	2021/11/22	Version updated
D.1.1	2024/03/07	Modify packaging naming

Pin Configuration and Functions (Top View)

RS2323

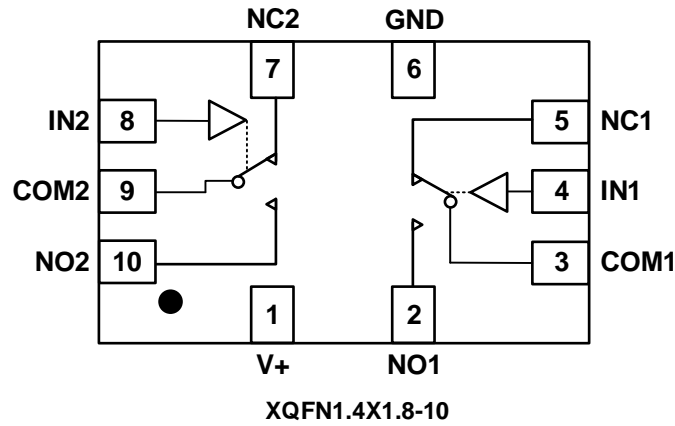

PIN DESCRIPTION

NAME	PIN	FUNCTION
	XQFN1.4X1.8-10	
V+	1	Power Supply
NO1, NO2	2,10	Normally-open terminal
COM1, COM2	3,9	Common terminal
IN1, IN2	4,8	Digital control pin to connect COM terminal to NO or NC terminals
NC1, NC2	5,7	Normally-closed terminal
GND	6	Ground

Function Table

LOGIC	NO	NC
0	OFF	ON
1	ON	OFF

SPECIFICATIONS

Absolute Maximum Ratings

Over operating free-air temperature range (unless otherwise noted) ⁽¹⁾

SYMBOL	PARAMETER	MIN	MAX	UNIT
V ₊	Supply voltage ⁽²⁾	-0.3	6	V
V _{IN}	Control Input voltage ⁽²⁾	-0.3	6	
V _{I/O}	Switch I/O voltage ⁽³⁾⁽⁴⁾	-0.3	(V ₊)+0.3	
I _{IN}	Continuous Current NO, NC or COM	-500	+500	mA
I _{I/O}	Peak Current NO, NC, or COM	-800	+800	
T _J	Junction temperature		150	°C
T _{stg}	Storage temperature	-65	+150	

(1) Stresses above these ratings may cause permanent damage. Exposure to absolute maximum conditions for extended periods may degrade device reliability. These are stress ratings only, and functional operation of the device at these or any other conditions beyond those specified is not implied.

(2) All voltages are with respect to ground, unless otherwise specified.

(3) The input and output negative-voltage ratings may be exceeded if the input and output clamp-current ratings are observed.

(4) This value is limited to 5.5 V maximum.

ESD Ratings

			VALUE	UNIT
V _(ESD)	Electrostatic discharge	Human-body model (HBM)	±1000	V
		Machine Model (MM)	±100	V

Recommended Operating Conditions

Over operating free-air temperature range (unless otherwise noted) ⁽³⁾

SYMBOL	PARAMETER	MIN	MAX	UNIT
V ₊	Supply voltage	1.8	5.5	V
I _N	Analog voltage	0	5.5	V
NO,NC,COM	Analog voltage	0	V ₊	V
T _A	Operating temperature	-40	+125	°C

Thermal Information

THERMAL METRIC		RS2323	UNIT
		10 PINS	
		XQFN1.4X1.8-10	
R _{θJA}	Junction-to-ambient thermal resistance	120	°C/W
R _{θJC(top)}	Junction-to-case (top) thermal resistance	46.0	°C/W
R _{θJB}	Junction-to-board thermal resistance	44.5	°C/W
ψ _{JT}	Junction-to-top characterization parameter	1.5	°C/W
ψ _{JB}	Junction-to-board characterization parameter	44.5	°C/W
R _{θJC(bot)}	Junction-to-case (bottom) thermal resistance	31.2	°C/W

PACKAGE/ORDERING INFORMATION

PRODUCT	ORDERING NUMBER	TEMPERATURE RANGE	PACKAGE LEAD	PACKAGE MARKING ⁽¹⁾	PACKAGE OPTION
RS2323	RS2323XUTQK10	-40°C ~125°C	XQFN1.4X1.8-10	2323X	Tape and Reel,4000

NOTE:

- (1) There may be additional marking, which relates to the lot trace code information (data code and vendor code), the logo or the environmental category on the device.
- (2) X = Date Code

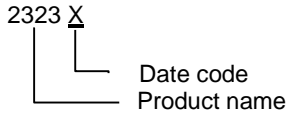
MARKING INFORMATION

ELECTRICAL CHARACTERISTICS

V+ = 5.0 V, T_A = -40°C to 125°C (unless otherwise noted)

PARAMETER	SYMBOL	CONDITIONS	V+	T _A	MIN	TYP	MAX	UNIT
ANALOG SWITCH								
Analog Signal Range	V _{NO} , V _{NC} , V _{COM}			FULL	0		V+	V
On-Resistance	R _{ON}	0 ≤ (V _{NO} or V _{NC}) ≤ V+, I _{COM} = -10mA, Switch ON, See Figure 16	5V	+25°C		0.6	1.0	Ω
				FULL			1.2	Ω
		V _{NO} or V _{NC} = 2V, I _{COM} = -10mA, Switch ON, See Figure 16	3.3V	+25°C		1.4	1.8	Ω
				FULL			2.0	Ω
On-Resistance Match Between Channels	ΔR _{ON}	0 ≤ (V _{NO} or V _{NC}) ≤ V+, I _{COM} = -10mA, Switch ON, See Figure 16	5V	+25°C		0.04	0.1	Ω
				FULL			0.12	Ω
		3.3V	+25°C		0.04	0.1	Ω	
			FULL			0.12	Ω	
On-Resistance Flatness	R _{FLAT(ON)}	0 ≤ (V _{NO} or V _{NC}) ≤ V+, I _{COM} = -10mA, Switch ON, See Figure 16	5V	+25°C		0.18	0.3	Ω
				FULL			0.4	Ω
		3.3V	+25°C		0.85	1.0	Ω	
			FULL			1.2	Ω	
NC,NO OFF Leakage Current	I _{NC(OFF)} , I _{NO(OFF)}	V _{NO} or V _{NC} = 0.3V, V+/2 V _{COM} = V+/2, 0.3V See Figure 17	1.8 to 5.5V	FULL			1	μA
NC,NO,COM ON Leakage Current	I _{NC(ON)} , I _{NO(ON)} , I _{COM(ON)}	V _{NO} or V _{NC} = 0.3V, Open V _{COM} = Open, 0.3V See Figure 18	1.8 to 5.5V	FULL			1	μA
DIGITAL CONTROL INPUTS⁽¹⁾								
Input High Voltage	V _{INH}		5V	FULL	1.5			V
			3.3V	FULL	1.3			V
Input Low Voltage	V _{INL}		5V	FULL			0.6	V
			3.3V	FULL			0.5	V
Input Leakage Current	I _{IN}	V _{IN} = V _{IO} or 0	1.8 to 5.5V	FULL			1	μA

(1) All unused digital inputs of the device must be held at V_{IO} or GND to ensure proper device operation.

ELECTRICAL CHARACTERISTICS (continued)

V₊ = 5.0 V, T_A = -40°C to 125°C (unless otherwise noted)

PARAMETER	SYMBOL	CONDITIONS	V ₊	T _A	MIN	TYP	MAX	UNIT
DYNAMIC CHARACTERISTICS								
Turn-On Time	t _{ON}	V _{COM} = V ₊ , R _L = 300Ω, C _L = 35pF, See Figure 20	5V	+25°C		35		ns
				FULL			50	
			3.3V	+25°C		55		
				FULL			70	
Turn-Off Time	t _{OFF}	V _{COM} = V ₊ , R _L = 300Ω, C _L = 35pF, See Figure 20	5V	+25°C		7.5		ns
				FULL			15	
			3.3V	+25°C		12		
				FULL			17	
Crosstalk	X _{TALK}	V ₊ =5.5V, Switch on, R _L =50Ω, F=100KHz	5.5V	+25°C		-80		dB
Break before make time	t _{BBM}	V ₊ =V _{COM} =5V, R _L =300Ω, C _L =35pF	5V	+25°C		2.5		ns
				FULL	1			
Off Isolation	O _{ISO}	R _L = 50Ω, Switch ON, See Figure 23	5.5V	+25°C		-70		dB
				f= 10KHz	5.5V	+25°C		-86
-3dB Bandwidth	BW	Switch ON, R _L = 50Ω, See Figure 22	5.5V	+25°C		110		MHz
NC, NO OFF Capacitance	C _{NC(OFF)} , C _{NO(OFF)}	V _{NC} or V _{NO} =V ₊ /2 or GND, Switch OFF See Figure 19	5V	+25°C		30		pF
NC,NO,COM ON Capacitance	C _{NC(ON)} , C _{NO(ON)} , C _{COM(ON)}	V _{NC} or V _{NO} =V ₊ /2 or GND, Switch ON See Figure 19	5V	+25°C		100		pF
POWER REQUIREMENTS								
Power Supply Range	V ₊			FULL	1.8		5.5	V
Power Supply Current	I ₊	V _{IN} = GND or V ₊	5.5V	+25°C			1	μA
				FULL			1	
Supply-Current Change	ΔI ₊	V ₊ =5.5V, V _{IN} =3.4V	5.5V	FULL			10	μA

TYPICAL CHARACTERISTICS

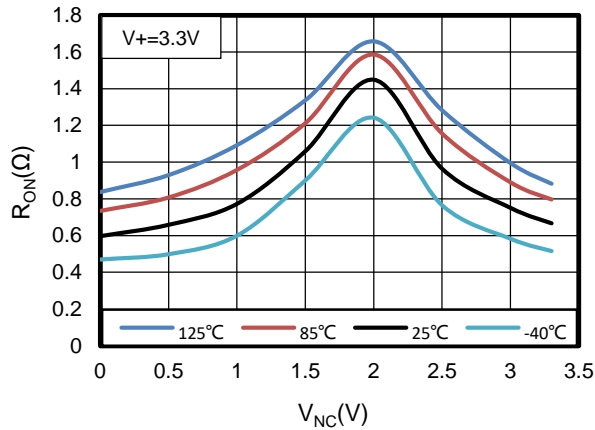

Figure 1. On-Resistance vs NC Voltage

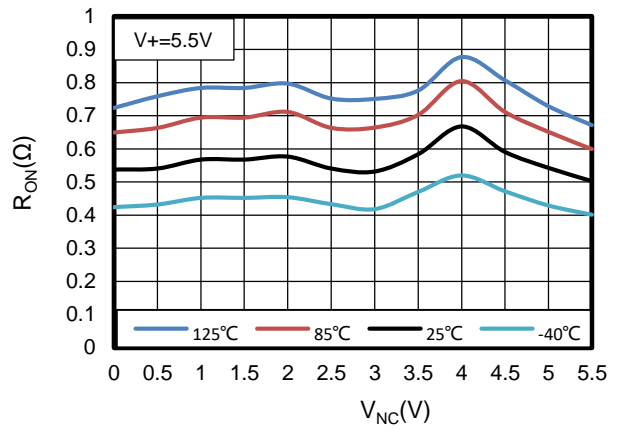

Figure 2. On-Resistance vs NC Voltage

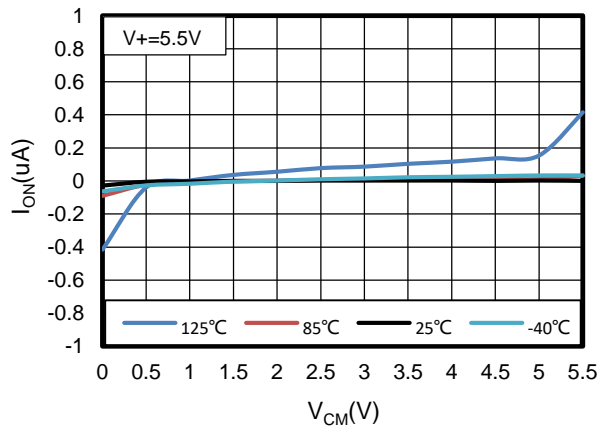

Figure 3. ON-State leakage current vs Common-Mode Voltage

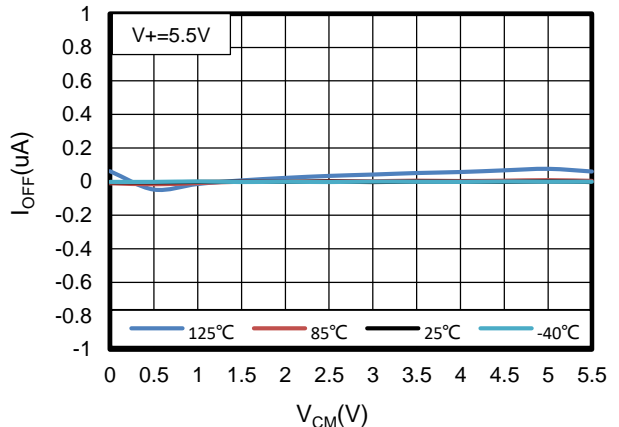

Figure 4. OFF-State leakage current vs Common-Mode Voltage

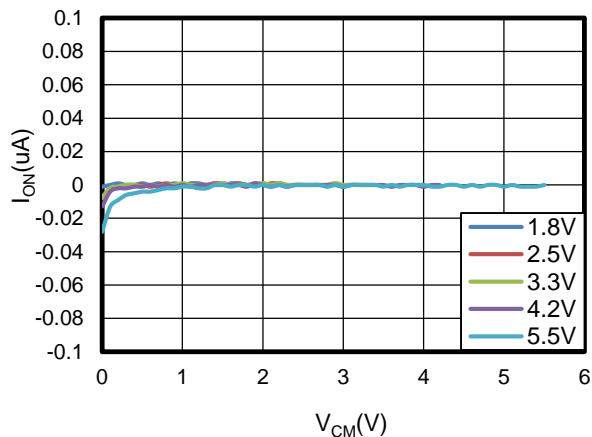

Figure 5. ON-State leakage current vs Common-Mode Voltage

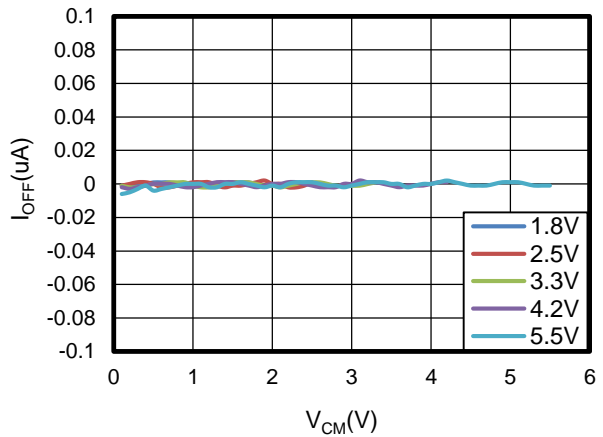

Figure 6. OFF-State leakage current vs Common-Mode Voltage

TYPICAL CHARACTERISTICS

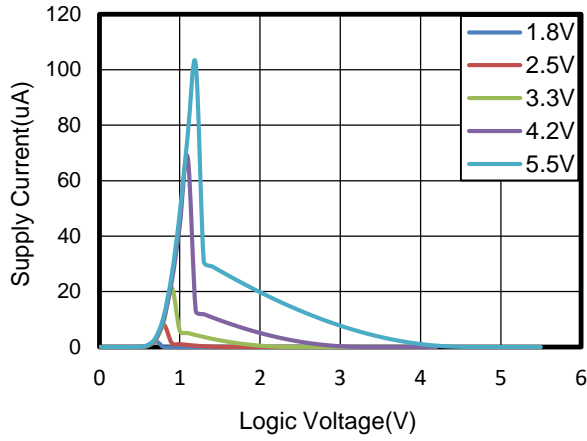

Figure 7. Supply Current vs Logic Voltage

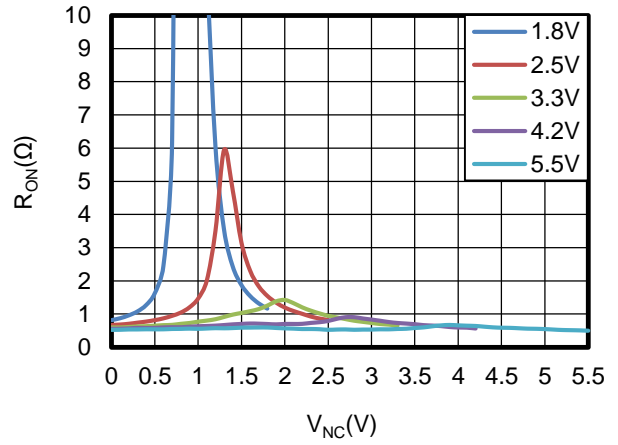

Figure 8. On-Resistance vs NC Voltage

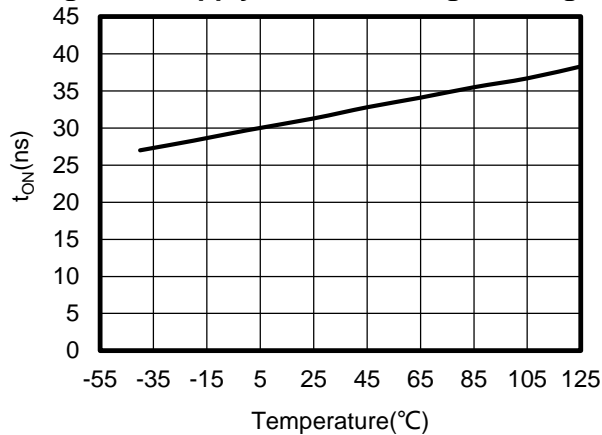

Figure 9. Turn on Time vs Temperature

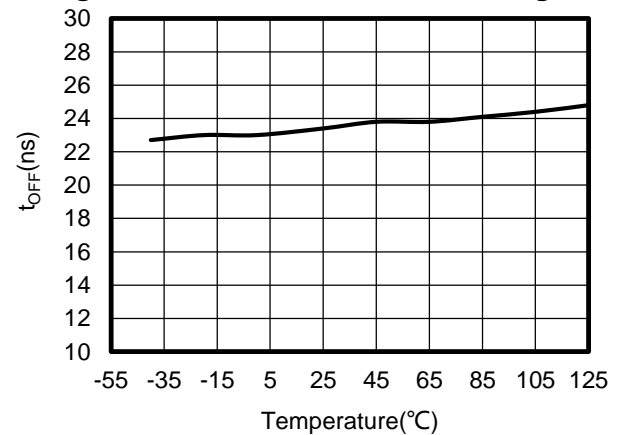

Figure 10. Turn-off Time vs Temperature

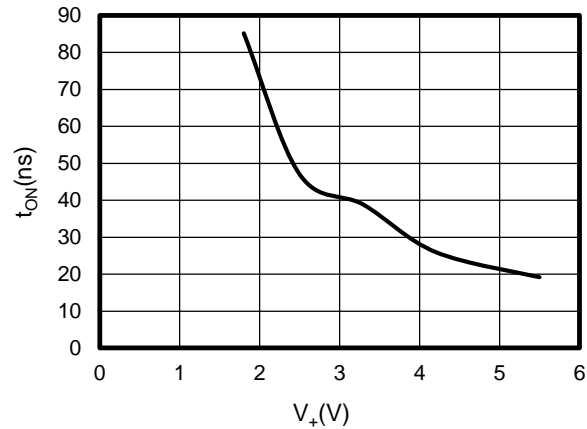

Figure 11. Turn On Time vs Supply Voltage

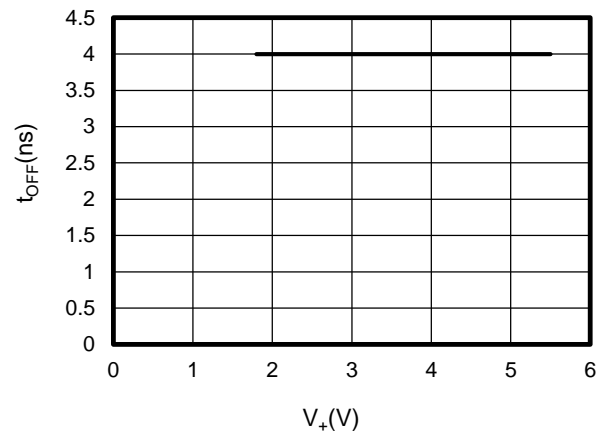

Figure 12. Turn-Off Time vs Supply Voltage

TYPICAL CHARACTERISTICS

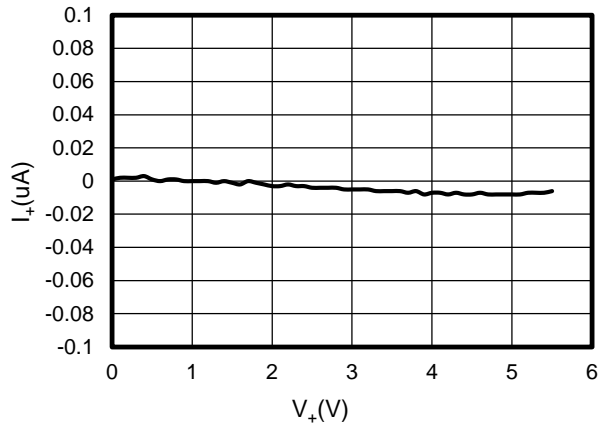

Figure 13. Supply Current vs Supply Voltage

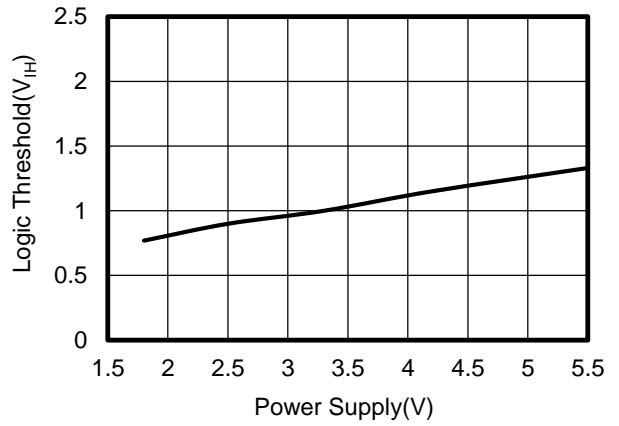

Figure 14. Logic Threshold vs Power Supply

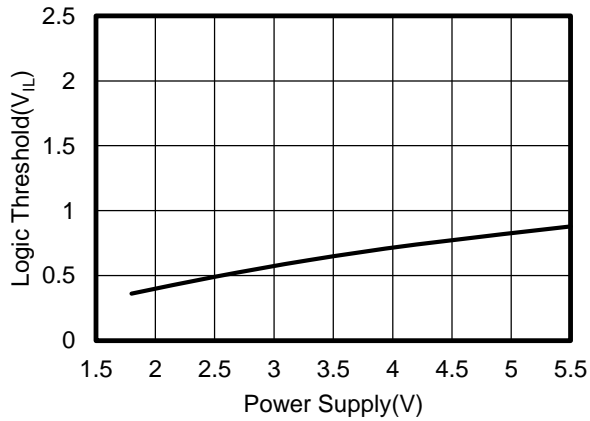

Figure 15. Logic Threshold vs Power Supply

Parameter Measurement Information

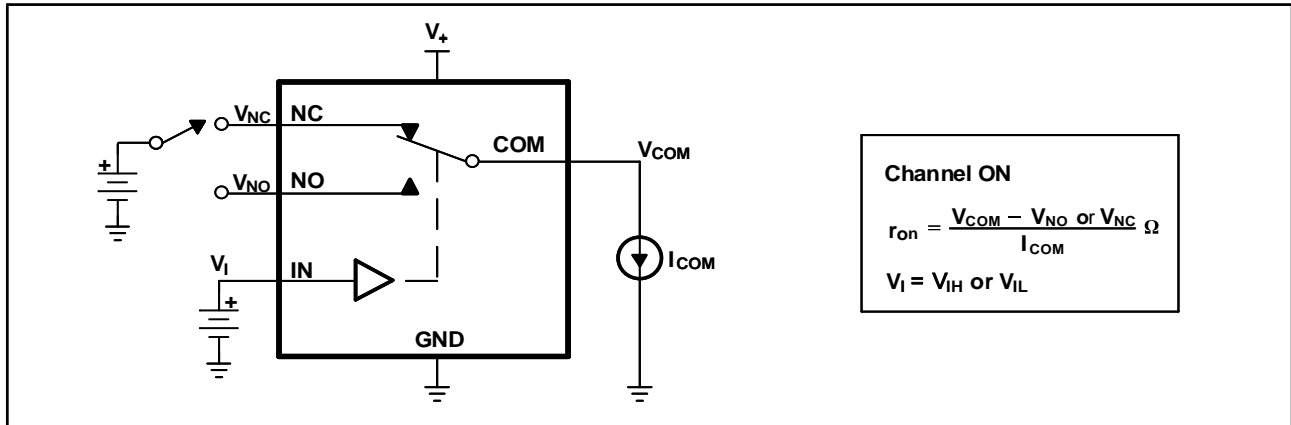

Figure 16. ON-State Resistance (r_{on})

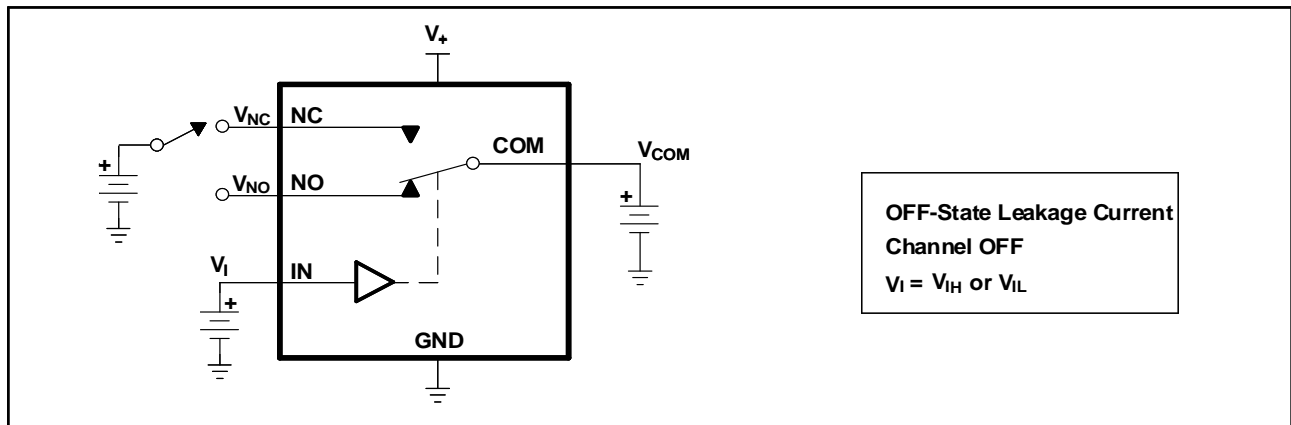

Figure 17. OFF-State Leakage Current ($I_{NC(OFF)}$, $I_{NO(OFF)}$)

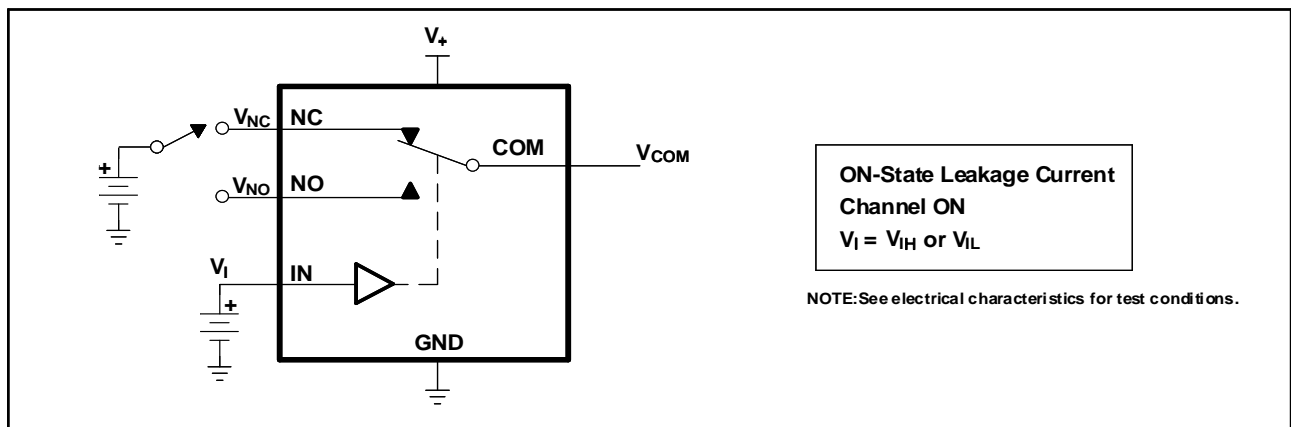

Figure 18. ON-State Leakage Current ($I_{COM(ON)}$, $I_{NC(ON)}$, $I_{NO(ON)}$)

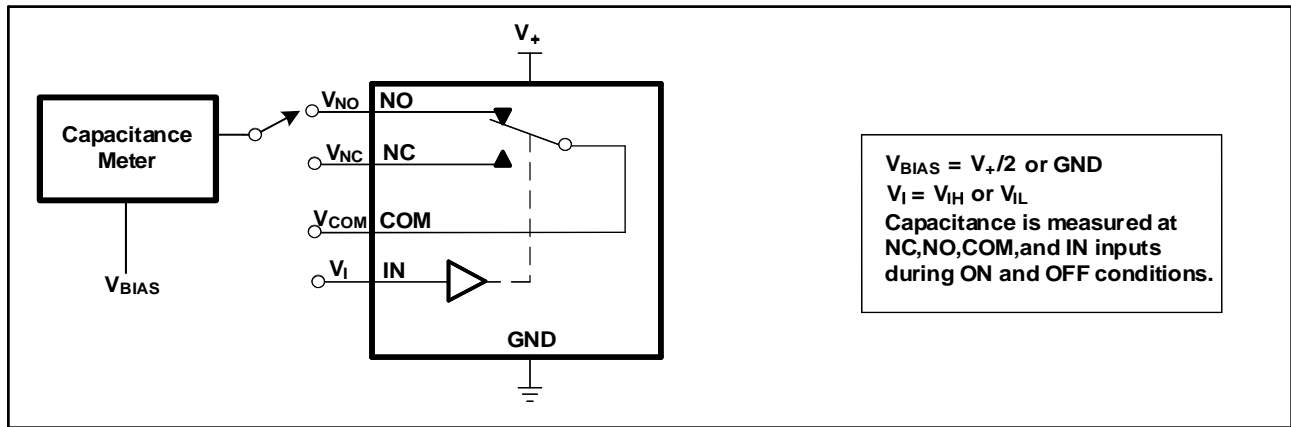

Figure 19. Capacitance (C_I , $C_{COM(ON)}$, $C_{NC(OFF)}$, $C_{NC(ON)}$, $C_{NO(OFF)}$, $C_{NO(ON)}$)

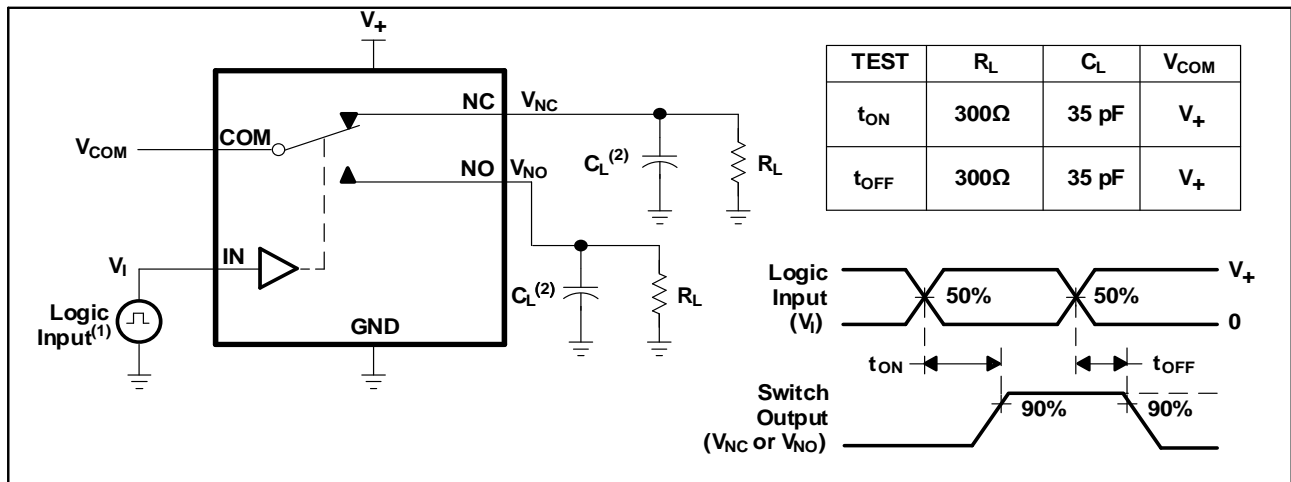

Figure 20. Turn-On (t_{ON}) and Turn-Off Time (t_{OFF})

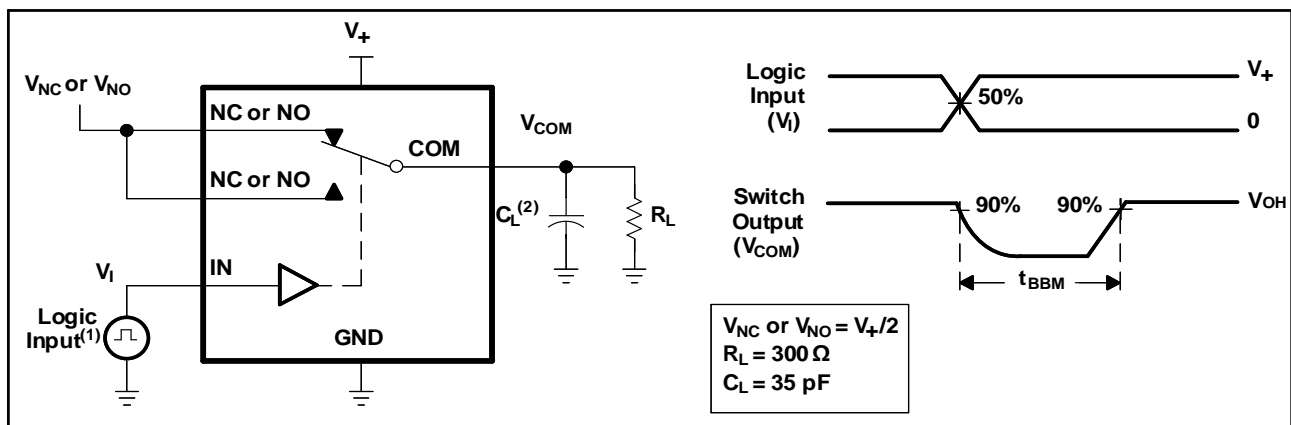

Figure 21. Break-Before-Make Time (t_{BBM})

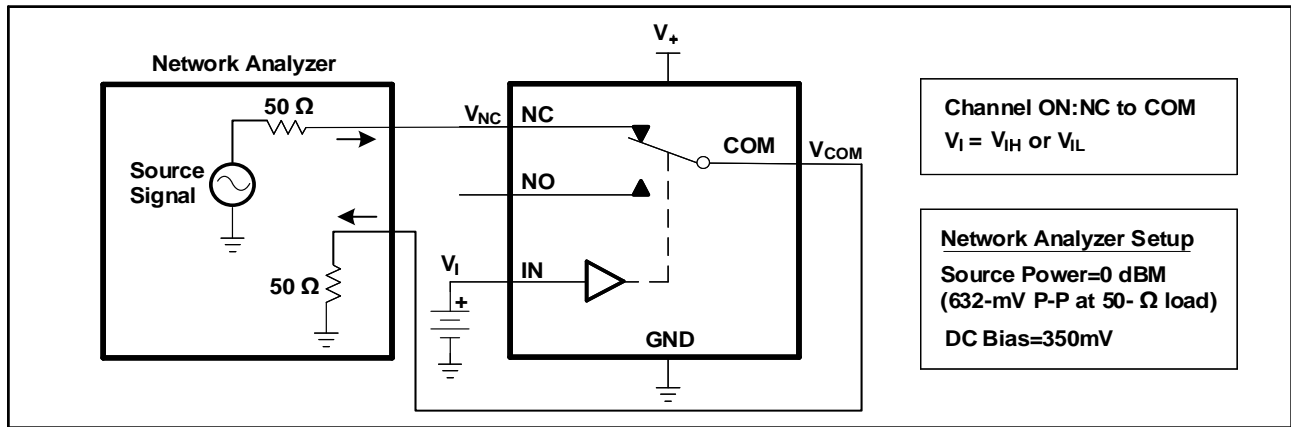

Figure 22. Bandwidth (BW)

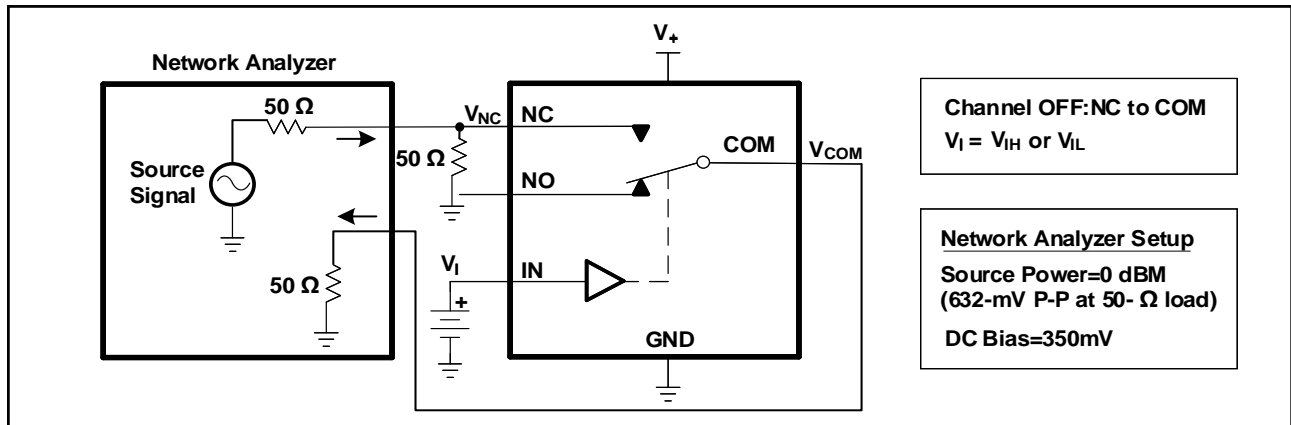

Figure 23. OFF Isolation (O_{ISO})

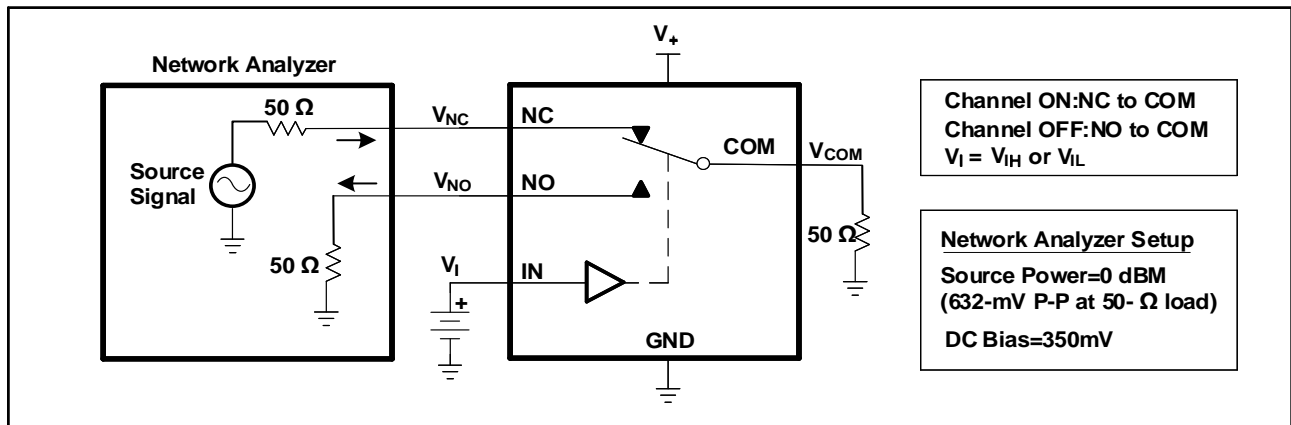

Figure 24. Crosstalk (X_{TALK})

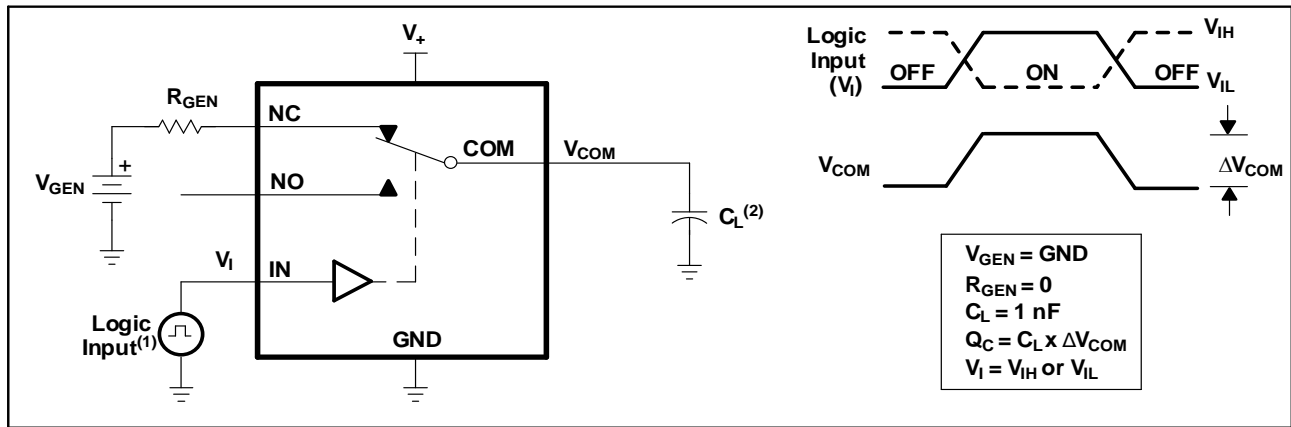

Figure 25. Charge Injection (Q_C)

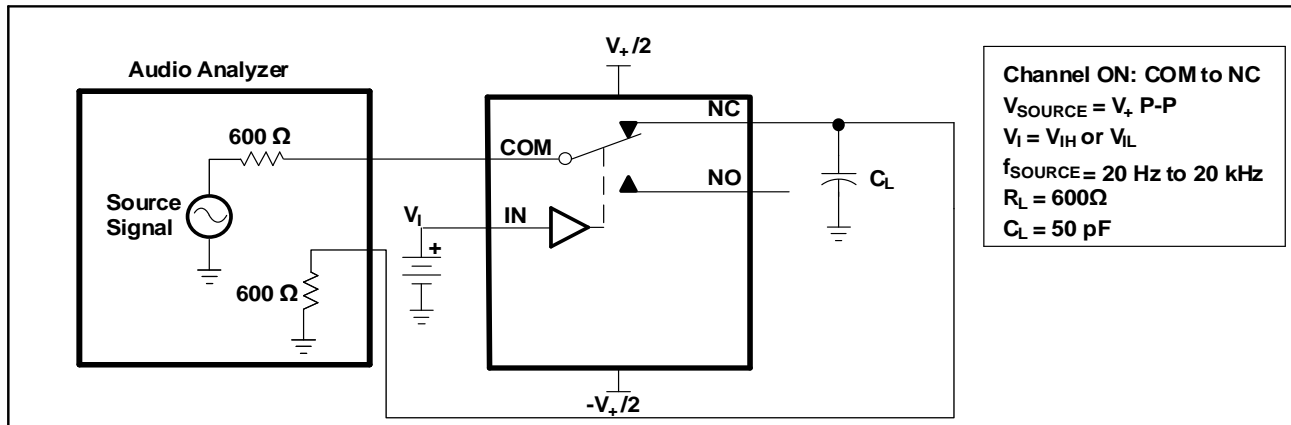
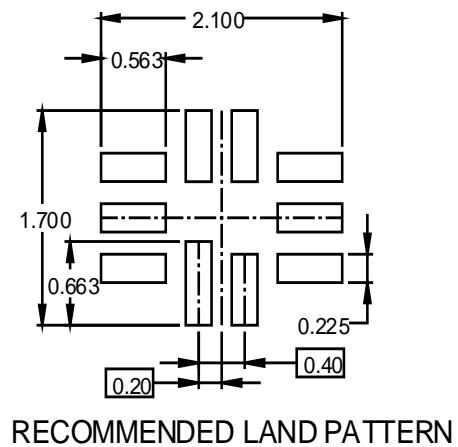
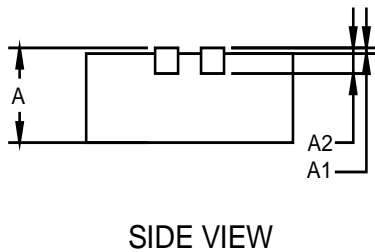
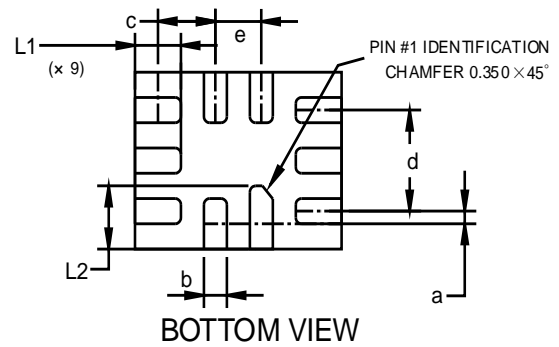
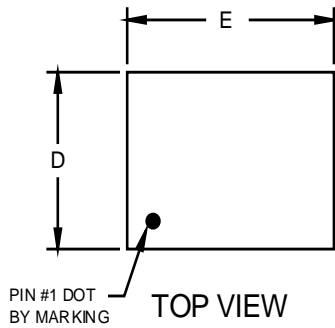

Figure 26. Total Harmonic Distortion (THD)

PACKAGE OUTLINE DIMENSIONS

XQFN1.4X1.8-10



Symbol	Dimensions In Millimeters		Dimensions In Inches	
	Min	Max	Min	Max
A	0.500	0.600	0.020	0.024
A1	0.000	0.050	0.000	0.002
A2	0.203 REF		0.008 REF	
a	0.050	0.150	0.002	0.006
b	0.150	0.250	0.006	0.010
c	0.450	0.550	0.018	0.022
d	0.800 REF		0.031 REF	
D	1.350	1.450	0.053	0.057
E	1.750	1.850	0.069	0.073
e	0.400 TYP		0.016 TYP	
L1	0.350	0.450	0.014	0.018
L2	0.450	0.550	0.018	0.022

TAPE AND REEL INFORMATION

REEL DIMENSIONS

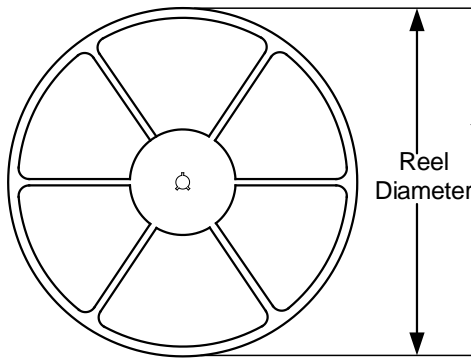

TAPE DIMENSION

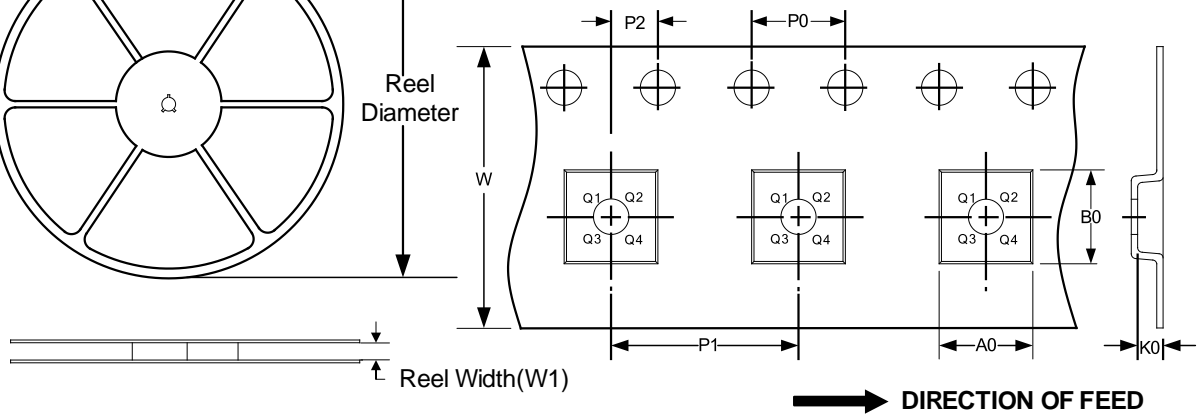

NOTE: The picture is only for reference. Please make the object as the standard.

KEY PARAMETER LIST OF TAPE AND REEL

Package Type	Reel Diameter	Reel Width (mm)	A0 (mm)	B0 (mm)	K0 (mm)	P0 (mm)	P1 (mm)	P2 (mm)	W (mm)	Pin1 Quadrant
XQFN1.4X1.8-10	7"	9.0	1.60	2.00	0.85	4.0	4.0	2.0	8.0	Q1